

1
2
3
4
5
6
7
8
9
10
11

COLORADO SECRETARY OF STATE

*This working draft shows and explains the substantive changes as of August 3, 2005. Proposed additions to the current rules are reflected in SMALL CAPS. Proposed deletions from the current rules are shown in ~~stricken type~~. Revisions to the July 25, 2005 working draft are shown in **bold text**. Annotations are included.*

12
13
14

PROPOSED ELECTION RULES

8 CCR 1505-1

15
16

Rule 1. Definitions

- 17 1.1 As used in these Rules and the “Uniform Election Code of 1992” unless the context
18 otherwise requires, the following terms shall have the meanings indicated:
19 “District office of state concern” means any of the following offices: Member of the
20 State Board of Education, Member of the Board of Regents of the University of
21 Colorado, and Member of the Board of Directors of the Regional Transportation District.

22
23

Rule 2. Rules Concerning Voter Registration

- 24 2.1 All requests for lists, printouts, disks, tapes, and other media shall be made in writing.
25 2.2 After a receipt of request, the cost of providing the information shall be determined. The
26 cost must be paid prior to the request being filled.
27 2.3 First Time Voter Who Registers by Mail. Prior to the implementation of the statewide
28 voter registration database, when a first time voter registers to vote by mail, the voter
29 shall provide a copy of one of the forms of identification listed in (a) or provide one of
30 the numbers listed in (b):
31 (a) The voter may provide a copy of one of the following forms of identification:
32 • A valid Colorado driver’s license;
33 • A valid identification card issued by the Department of Revenue IN
34 ACCORDANCE WITH THE REQUIREMENTS OF PART 3 OF ARTICLE 2 OF TITLE
35 42, C.R.S.;
36 • A valid U.S. passport;
37 • A valid employee identification card with a photograph of the eligible
38 elector issued by any branch, department, agency, or entity of the United
39 States government or of this state, or by any county, municipality, board,
40 authority, or other political subdivision of this state;
41 • A valid pilot’s license issued by the federal aviation administration or
42 other authorized agency of the United States;
43 • A valid U.S. military identification card with a photograph OF THE
44 ELIGIBLE ELECTOR;
45 • A copy of a current utility bill, bank statement, government check,
46 paycheck, or other government document that shows the name and

1 address of the elector. (A cable bill, a telephone bill, documentation from
2 a public institution of higher education in Colorado containing at least the
3 name, date of birth, and LEGAL residence address of the student elector, or
4 a paycheck from a government institution or private company are
5 sufficient forms of ID);

Formatted

- 6 ● A valid Medicare or Medicaid card ISSUED BY THE UNITED STATES
7 HEALTH CARE FINANCING ADMINISTRATION;
- 8 ● A certified copy of a U.S. birth certificate FOR THE ELECTOR ISSUED IN THE
9 UNITED STATES; or
- 10 ● Certified documentation of naturalization;

11 (b) Or the voter may provide one of the following numbers (without providing a
12 physical copy of the number):

- 13 ● At least the last four digits of the person's social security number;
 - 14 ● The person's valid Colorado Driver's License number; or
 - 15 ● The person's valid Department of Revenue ID number issued by the
16 Department of Revenue.
- 17 (i) IF THE NUMBER PROVIDED IS VERIFIED WITH A NUMBER ON AN EXISTING
18 STATE IDENTIFICATION RECORD PER RULE 30.5, THE ELECTOR SHALL NOT BE
19 REQUIRED TO SUPPLY ID WITH A MAIL OR ABSENTEE BALLOT.
- 20 (ii) IF THE NUMBER PROVIDED CANNOT BE VERIFIED WITH A NUMBER ON AN
21 EXISTING STATE IDENTIFICATION RECORD PER RULE 30.5, THE ELECTOR
22 SHALL BE "ID TAGGED" AND REQUIRED TO SUPPLY ID PER 1-1-104(19.5)
23 C.R.S. WITH A MAIL OR ABSENTEE BALLOT.

24 Authority: 1-2-501(2)(B) C.R.S.; 1-1-104(19.5) C.R.S.

25 2.4 First Time Voter Who Registers in Person. Prior to the implementation of the statewide
26 voter database, when a first time voter registers in person, the voter shall be requested to
27 provide the number of one of the following forms of identification:

- 28 ● Valid Colorado Driver's License number; or
- 29 ● Valid Department of Revenue Identification number; or
- 30 ● At least the four last digits of the person's social security number.

31 Authority: 1-2-204(2)(f.5)C.R.S.

32 2.4.1 Prior to the implementation of a statewide voter registration database, if a voter
33 registering in person does not have a valid Colorado driver's license, a current and
34 valid identification card issued by the department of revenue or a social security
35 number, the election official shall assign the applicant a unique identifier that will
36 serve to identify the applicant for voter registration purposes. See 1-2-
37 204(2.5)C.R.S.

38 2.5 Confidentiality of Agency in Voter Registration. For Voter Registration Applications
39 Completed pursuant to Part 5 of Article 2 of Title 1, C.R.S., at an agency designated by
40 the National Voter Registration Act of 1993, no information regarding the name and
41 location of the designated voter registration agency shall be provided to the public, and
42 such information shall remain confidential.

43 2.6 Emergency Registration Application. Prior to the implementation of the statewide voter
44 registration database, when an elector completes an emergency registration application
45 pursuant to 1-2-217.5 (1)(b)C.R.S., the elector shall be required to present one of the
46 following forms of identification listed in Rule 2.3(a);

Formatted

- ~~● A valid Colorado driver's license;~~
- ~~● A valid identification card issued by the Department of Revenue IN ACCORDANCE WITH THE REQUIREMENTS OF PART 3 OF ARTICLE 2 OF TITLE 42, C.R.S.;~~
- ~~● A valid U.S. passport;~~
- ~~● A valid employee identification card with a photograph of the eligible elector issued by any branch, department, agency, or entity of the United States government or of this state, or by any county, municipality, board, authority, or other political subdivision of this state;~~
- ~~● A valid pilot's license issued by the federal aviation administration or other authorized agency of the United States;~~
- ~~● A valid U.S. military identification card with a photograph OF THE ELIGIBLE ELECTOR;~~
- ~~● A copy of a current utility bill, bank statement, government check, paycheck, or other government document that shows the name and address of the elector; (A cable bill, a telephone bill, documentation from a public institution of higher education in Colorado containing at least the name, date of birth, and LEGAL residence address of the student elector, or a paycheck from a government institution are sufficient forms of ID);~~
- ~~● A valid Medicare or Medicaid card ISSUED BY THE UNITED STATES HEALTH CARE FINANCING ADMINISTRATION;~~
- ~~● A certified copy of a U.S. birth certificate FOR THE ELECTOR ISSUED IN THE UNITED STATES; or~~
- ~~● Certified documentation of naturalization.~~

2.7 CONFIDENTIALITY OF VOTER INFORMATION. PURSUANT TO 24-72-204(3.5)(B)(II) AND (IV) C.R.S., THE COUNTY CLERK AND RECORDER OF THE COUNTY WHERE THE INDIVIDUAL RESIDES SHALL PROVIDE AN OPPORTUNITY TO MAKE THE REQUEST OF CONFIDENTIALITY IN PERSON AT THE TIME SUCH INDIVIDUAL REGISTERS TO VOTE OR MAKE ANY CHANGE IN THE INDIVIDUAL'S REGISTRATION, AND AT ANY OTHER TIME DURING THE NORMAL BUSINESS HOURS OF THE OFFICE OF THE COUNTY CLERK AND RECORDER.

2.7.1 THE VOTER'S NAME, ADDRESS, AND BIRTH DATE SHALL BE LISTED ON THE CONFIDENTIALITY APPLICATION. A CONFIDENTIALITY AFFIRMATION SHALL BE PRINTED ON THE FORM, IN THE AREA IMMEDIATELY ABOVE A LINE FOR THE APPLICANT'S SIGNATURE AND THE DATE. THE AFFIRMATION SHALL STATE THE FOLLOWING:

"I SWEAR OR AFFIRM, UNDER PENALTY OF PERJURY, THAT I HAVE REASON TO BELIEVE THAT I OR A MEMBER OF MY HOUSEHOLD WILL BE EXPOSED TO CRIMINAL HARASSMENT, OR OTHERWISE BE IN DANGER OF BODILY HARM, IF MY ADDRESS IS NOT KEPT CONFIDENTIAL"

2.7.2 IMMEDIATELY BELOW THE SIGNATURE LINE, THERE SHALL BE A PRINTED NOTICE, IN A TYPE THAT IS LARGER THAN THE OTHER INFORMATION CONTAINED ON THE FORM, THAT THE APPLICANT MAY BE PROSECUTED FOR PERJURY IN THE SECOND DEGREE UNDER 18-8-503 C.R.S., IF THE APPLICANT SIGNS SUCH AFFIRMATION AND DOES NOT BELIEVE SUCH AFFIRMATION TO BE TRUE.

2.7.3 A VOTER MAKING AN ADDRESS CHANGE WITHIN THE SAME COUNTY SHALL NOT BE CHARGED AN ADDITIONAL PROCESSING FEE.

Rule 3. Rules Concerning Qualified Political Organizations

- 1 3. Qualified Political Organization as identified by order of the 10th Circuit Court of
2 Appeals (Baer v. Meyer, 728 F2d 471, 10th Cir. 1984).
- 3 3.1 A qualified political organization is one which has placed a candidate for a congressional
4 district or state office on the ballot at a congressional vacancy or general election and
5 whose officers have filed the required proof of organization with the Secretary of State
6 and continues to meet the requirements of 3.3 and 3.4.
- 7 3.2 The required proof of organization, which may be filed at any time after organization,
8 shall include, but shall not be limited to:
- 9 a. By-laws of the Colorado political organization which shall include the method for
10 selecting officers, selecting delegates to county, state, and national conventions,
11 and selecting candidates planning to petition onto the state's general election
12 ballot using the name of the Colorado political organization;
- 13 b. The names, addresses, and telephone numbers of the elected Colorado
14 chairperson, vice chairperson, and secretary, together with the names, addresses,
15 and telephone numbers of all other members elected or appointed to other offices
16 or committees authorized by the by-laws.
- 17 3.3 Qualified political organizations shall meet once a year.
- 18 3.3.1 The meeting in the odd-numbered year shall be held for the purpose of electing a
19 chairperson, vice-chairperson, secretary and other officers or committees as shall
20 be provided for in the by-laws on file with the Secretary of State.
- 21 (a) For new political organizations, this meeting must take place prior to
22 placing a candidate on the ballot. Therefore, this meeting may occur in an
23 even-numbered year.
- 24 3.3.2 The chairperson and the secretary shall file a full and complete list, under oath, of
25 the persons elected or appointed pursuant to Rule 3.2, together with any
26 amendments to the by-laws adopted at the meeting.
- 27 3.3.3 The meeting in the even-numbered year shall be held for the purpose of selecting
28 candidates who wish to use the name of the political organization on petitions for
29 the next general election.
- 30 (a) A political organization which has not yet been qualified may select its
31 candidate at the same meeting where the officers of the organization are
32 named.
- 33 3.4 A qualified political organization shall place a candidate or candidates on the general
34 election ballot every two years.
- 35 3.4.1 Candidates wishing to represent a qualified political organization on the general
36 election ballot shall be placed in nomination by nominating petition pursuant to 1-
37 4-802 C.R.S.
- 38 3.4.2 Each petition shall contain the name of one candidate and shall have attached an
39 affidavit signed under oath by the chairperson and secretary of the qualified
40 political organization. The affidavit form shall be approved by the Secretary of
41 State and will include the date of the meetings required in Rule 3.3.
- 42 3.4.3 For a candidate to qualify for the ballot, the candidate must have been affiliated
43 with the qualified political organization for one year, or if the political
44 organization has not previously been qualified, the candidate must have been
45 registered as unaffiliated for one year.

- 1 3.4.4 Having the name of a candidate from the qualified political organization appear
2 on the ballot by the use of the write-in candidacy process shall not be considered
3 as, nor meeting the requirements of, placing a qualified candidate on the general
4 election ballot.
- 5 3.5 A political organization shall be qualified as soon as it:
6 a. Files proof of organization with the Secretary of State;
7 b. Meets to name a candidate to the general election ballot; and
8 c. Certifies a candidate to the general election ballot.
- 9 3.6 Once a political organization becomes a qualified political organization, eligible electors
10 shall be able to register as affiliated with the political organization.
- 11 3.6.1 When an individual appears at any office or location for the purpose of voter
12 registration, the questions asked and the information recorded shall be amended to
13 reflect "political organization" affiliation.
- 14 3.6.2 The opportunity to declare or change a political affiliation shall be provided
15 exactly as the law provides for political parties in 1-2-204(2)(j) C.R.S. and 1-2-
16 219 C.R.S.
- 17 3.6.3 At any time a declaration or change in affiliation is requested, the same procedure
18 shall be used for declaring a political party or political organization affiliation.
- 19 3.6.4 In recording the information on the voter registration page, or affidavit, the
20 affiliation with a political organization shall be listed by the name entry of the
21 organization.
- 22 3.6.5 In converting information on the voter registration page to lists, submissions for
23 data entry, the Secretary of State's master voter registration list, etc., standard
24 abbreviations shall be used and will be furnished to the county clerk and recorders
25 by the Secretary of State.
- 26 3.7 Political organizations shall lose their status as qualified political organizations by failing
27 to do any one of the following:
28 a. Meet in odd-numbered years and file their list of officers with the Secretary of
29 State, unless excused under Rule 3.3.1(a);
30 b. Meet in even-numbered years and select a candidate or candidates who wish to
31 appear on the ballot at the next general election;
32 c. Place a candidate on a general election ballot through a nominating petition,
33 meeting the requirements of Rule 3.4.
- 34 3.8 The Secretary of State will notify the county clerk and recorders by June 1 of each odd-
35 numbered year of the loss of qualified status of a political organization. Upon receiving
36 notification, the county clerk and recorders shall MARK on every affected voter
37 registration record UNAFFILIATED."
- 38 3.9 Print-outs, lists, tapes, etc. of voter registration records shall be furnished to qualified
39 political organizations at the same rate or cost as charged to political parties. The only
40 exception to this provision shall be the list furnished to the major political parties prior to
41 the statutory precinct caucus day.
- 42 3.10 On all summary reports of voter registration by political party, THE REPORT SHALL LIST
43 THOSE REGISTERED WITH MAJOR POLITICAL PARTIES, MINOR POLITICAL PARTIES, QUALIFIED
44 POLITICAL ORGANIZATIONS, OR AS UNAFFILIATED.3.11 Electors, whose voter
45 registration record shows affiliation with a qualified political organization and who

1 appear to vote at a primary election, shall complete a Declaration of Party Affiliation,
2 thus losing affiliation with the qualified political organization.

3 **Rule 4. Rules Concerning Circulation of Candidate Petitions**

4 4.1 No petition for candidacy for any non-partisan office shall be circulated prior to 90 days
5 before the election, EXCEPT AS PROVIDED IN 1-4-805 C.R.S.

6 **Rule 5. Rules Concerning Non-Partisan Elections not Coordinated by the County
7 Clerk**

8 5.1 For elections conducted on days other than described in section 1-7-116 (1) C.R.S.,
9 nothing shall preclude the designated election official from mailing the notice required by
10 Article X, Section 20 of the Colorado Constitution to persons who are not eligible
11 electors, if such mailing is done at the “least cost” possible.

12 5.2 If there are no appropriate polling place locations within the political subdivision
13 conducting the election, a polling place may be designated outside of the political
14 subdivision in a location that is convenient for the eligible electors of such political
15 subdivision.

16 5.3 For elections not conducted in November and not coordinated with the county clerk and
17 recorder, the ballot issue or question shall be identified by the name of the jurisdiction
18 submitting the ballot issue or ballot question followed by a number in the case of
19 initiatives or by a letter in the case of referred measures.

20 5.4 Elections authorized under Part 1, Article 45 of Title 37, C.R.S. (Water Conservancy
21 Act), shall be conducted in accordance with Articles 1 through 13 of Title 1, C.R.S.,
22 where applicable, unless otherwise ordered by the district court having jurisdiction over
23 the water conservancy district, pursuant to section 37-45-103 (3), C.R.S. (“Court”).

24 5.4.1 The form and verification of any petition requesting an election conducted by a
25 water conservancy district pursuant to section 37-45-114 (2), C.R.S. (“Petition”),
26 shall conform with the requirements of sections 1-40-113 and 1-40-116, C.R.S.
27 and the sections cited therein, and Rule 22 of these rules; except that no prior
28 approval of the form of such election petition needs to be provided by the
29 Secretary of State, the petition shall be filed with the Court and the verification
30 process shall be directed by the water conservancy district named in the petition
31 rather than the Secretary of State, and the “warning” language appearing on the
32 petition shall be applicable to the election requested to be conducted.

33 5.4.2 The procedures for issuing the statement of sufficiency or insufficiency of the
34 petition shall conform with the requirements of Section 1-40-117, C.R.S and Rule
35 22.4 of these rules; except that such statement shall be issued by the water
36 conservancy district named in the petition, unless otherwise ordered by the Court.

37 5.4.3 The procedures for cure of a petition deemed insufficient shall conform with the
38 requirements of Section 1-40-117, C.R.S. and Rule 19 of these rules; except any
39 addendum to the petition shall be filed with both the Court and the water
40 conservancy district named in the petition, unless otherwise ordered by the Court.

41 5.4.4 The procedures for protesting the determination that a petition is insufficient shall
42 conform with the requirements of sections 1-40-118, C.R.S. and Rule 20 hereof,
43 unless otherwise ordered by the Court.

44 5.4.5 Upon final determination of the sufficiency of a petition, the court shall order,
45 regardless of the actual expiration date of the term of the office subject to the
46 court-ordered election, the holding of the election to be conducted no more than

1 100 days nor less than 60 days from the date of such Court order, unless the water
2 conservancy district has notified the Court that such election is to be conducted as
3 a coordinated election pursuant to Section 1-7-116, C.R.S.

4 5.4.6 The form and procedures for filing candidate nomination forms and call for
5 nominations of persons desiring to be a candidate for the office to be voted upon
6 at the Court-ordered election described in Rule 5.4.5 of these rules, shall be in
7 conformance with the form and procedures required for special districts under
8 Article 1, Title 32, C.R.S., unless otherwise ordered by the Court.

9 5.5 Non-Partisan Elections: Polling Place Procedures.

10 5.5.1 For polling place elections being conducted in accordance with Article 1, Title 32,
11 C.R.S., upon execution of the self-affirming oath or affirmation pursuant to
12 Section 32-1-806(2) C.R.S., the eligible elector desiring to vote shall show his or
13 her identification as defined in Section 1-1-104(19.5), C.R.S. to one of the
14 election judges. 1-7-110(1)C.R.S.

15 5.5.2 If the eligible elector has executed the self-affirming oath or affirmation and
16 provided his or her identification, such eligible elector may be allowed to vote, if
17 such vote is not challenged. 1-7-110(2) and 32-1-806(4) C.R.S.

18 5.5.3 The election supplies provided to the supply judge of each polling place shall
19 include an adequate number of provisional ballot envelopes that INCLUDE THE
20 AFFIDAVIT SET FORTH IN RULE 26.8.

21 5.5.4 The signature and date on the provisional ballot affidavit envelope shall remain on
22 the outside of the envelope. *Note: This rule is replaced by Rule 26.9.*

23 5.5.6 The provisional ballot affidavit envelope shall be numbered to correspond to the
24 number of the provisional elector's name in the poll book, and the word
25 "provisional" shall be marked on the ballot.

26 5.5.7 Verification of Information in Provisional Ballot Affidavit. The Designated
27 Election Official shall verify the information contained in the provisional ballot
28 affidavit pursuant to Rule 26. If the information contained in the affidavit
29 provides adequate criteria such that the designated election official, using the Rule
30 26 search, can ascertain the registration of the elector, the provisional ballot shall
31 count. If the information cannot be verified, the ballot shall be rejected. See 1-
32 8.5-105 AND RULE 26.

33 5.5.8 The verification and counting of all provisional ballots shall be completed prior to
34 the certification of the official abstract of votes cast in the election by the canvass
35 board, pursuant to Section 1-10-203(1), C.R.S.

36 5.5.9 Canvassing Board's Count of Provisional Ballots. If, after the expiration of
37 twelve days following an election, the election judges cannot complete the count
38 of the provisional ballots cast, the canvassing board appointed pursuant to Section
39 1-10-201(1.5), C.R.S. shall complete the count of such provisional ballots.

40 5.5.10 If 25 or more provisional ballots have been cast and counted, the results shall be
41 reported as one total. If less than 25 provisional ballots have been cast and
42 counted, the results shall be included in the results of the absentee ballots counted
43 in the election.

44 5.5.11 The provisional ballot shall not be counted if the elector failed to complete the
45 affidavit on the envelope or the elector was not registered by the deadline in the
46 State of Colorado.

1 5.5.12 A copy of the provisional ballot affidavit shall be provided to the County Clerk
2 and Recorder of the county of the elector's residence, and shall constitute a voter
3 registration for future elections. 1-8.5-108 C.R.S.

4 **Rule 6. Rules Concerning Coordinated Elections**

5 6.1 Participation in coordinated elections.

6 6.1.1 For elections where the electors do not need to be registered electors, political
7 subdivisions may conduct their own elections and must coordinate with the
8 coordinated election official any ballot issue notice required by Article X, Section
9 20 of the Colorado Constitution.

10 6.1.2 The affected political subdivision shall enter into intergovernmental agreements
11 which delineate which tasks shall be the responsibility of the designated election
12 official of the political subdivision and which shall be the responsibility of the
13 coordinated election official.

14 6.2 Form of election for November coordinated elections.

15 6.2.1 The county clerk and recorder is the election official for coordinated elections
16 which are held in November of each year.

17 (a) The county clerk and recorder shall be responsible for mailing the Article
18 X, Section 20 Ballot Issue notice.

19 (b) The county clerk and recorder shall not be required to conduct more than
20 one form of election unless he or she so chooses.

21 6.2.2 If the county clerk and recorder, after consultation with the other political
22 subdivisions, elects to conduct a mail ballot election, upon application to and
23 approval by the Secretary of State showing why a separate mail ballot election is
24 needed and why it will benefit the electorate, a political subdivision may conduct
25 its own mail ballot election.

26 6.2.3 School districts that have the opportunity to participate in a coordinated election
27 may not elect to hold separate mail ballot elections but must participate in the
28 form of election chosen by the county clerk and recorder.

29 6.3 Form of coordinated elections held other than in November.

30 6.3.1 For all other elections where political subdivisions hold an election on the same
31 day, the electors or boundaries overlap and ballot issues as defined in Section 1-1-
32 104 (2.3), C.R.S., appear on the ballot of overlapping jurisdictions, the governing
33 bodies or the designated election officials of such overlapping jurisdictions must
34 name a coordinated election official who is responsible for assuring that the
35 Article X, Section 20 notice is given.

36 6.3.2 The political subdivisions may contract with the appropriate county clerk and
37 recorder to be the coordinated election official.

38 6.4 Determination of ballot issues and texts.

39 6.4.1 Each political subdivision shall prepare the list of candidates and the ballot title
40 and text for ballot issues and ballot questions, as required by law.

41 (a) The coordinated election official shall assure that the ballot title is on each
42 ballot as required by law.

43 (b) Political subdivisions may only require the coordinated election official to
44 print the entire text of a ballot issue or ballot question on the ballot if they
45 pay for any additional cost associated with printing and if sufficient space
46 is on the voting equipment to print the entire text given the other issues,

1
2
3
4
5
6
7
8
9
10
11
12
13
14
15
16
17
18
19
20
21
22
23
24
25
26
27
28
29
30
31
32
33
34
35
36
37
38
39

questions, and candidates on the ballot. The coordinated election official shall tell the political subdivision how much space is available for text for each position on the ballot. If the required ballot title and text is too long for the voting equipment, the coordinated election official may choose to conduct the election with a different form of ballot.

- (c) For counties where ballot election material must be printed in languages other than English, the political subdivisions are responsible for assuring proper translation of all election materials related to that political subdivision and must pay their pro-rata share of increased printing costs unless otherwise provided by the intergovernmental agreement.
- (d) For counties where election material is not required to be printed in languages other than English, the political subdivisions are not required to provide translation of all election materials nor pay a pro-rata share of the printing costs unless they so agree.

6.4.2 Each political subdivision shall determine the order of the ballot issues for their political subdivision in accordance with the requirements of Colorado Constitution Article X, Section 20 and Title 1.

- (a) Initiatives shall be designated by a number, referred measures shall be designated by a letter or by a number and a letter.
- (b) For each grouping of ballot issues and ballot questions by a political subdivision, all initiatives shall precede all referred measures.
- (c) For each grouping of ballot issues and ballot questions, the order shall be as follows:
 - 1. Initiatives to increase taxes;
 - 2. Initiatives to increase debt;
 - 3. Other citizen petitions;
 - 4. Referred measures to increase taxes;
 - 5. Referred measures to increase debt;
 - 6. Other referred measures.
- (d) For statewide measures, initiatives shall be numbered in the order in which the statements of sufficiency are issued. The numbers one through five shall be reserved for initiatives to increase taxes; the numbers six through ten shall be reserved for initiatives to increase debt; all other citizen petitions shall be numbered consecutively beginning with eleven.
- (e) Ballot issues from the various political subdivisions shall be ordered on the ballot as provided in 1-5-407 (5) C.R.S:
 - 1. Each category of initiated ballot issues and questions shall be numbered in the following series:

01-99	State Issues
100-199	County Issues
200-299	Municipal Issues
300-399	School District Issues
400-499	Ballot issues and questions for other political subdivisions greater than a county.
500-599	Ballot issues and questions for other

	political subdivisions which are wholly within a county.
--	--

2. Each category of referred ballot issues and questions shall be designated by a letter or a number and a letter in the following series:

A-Z	State Issues
1A-1Z	County Issues
2A-2Z	Municipal Issues
3A-3Z	School District Issues
4A-4Z	Ballot issues and questions for other political subdivisions greater than a county.
5A-5Z	Ballot issues and questions for other political subdivisions which are wholly within a county.
6A-6Z	Other Issues and Questions

3. Ballot questions and issues are numbered or lettered in the order in which the measures are certified to the ballot by the designated election official after the protest period has ended, or if a protest was filed after the protest has been completed.
4. For other than state issues, if a county has multiple cities and/or multiple discrete school districts and other political subdivisions, the designated election official may either further subdivide the series and assign each political subdivision a specific series of numbers, or when the ballot is certified the designated election official may assign the final numbers/letters, making sure that all measures for each political subdivision are grouped together.
5. For other than state issues and questions, if the same ballot issue or question will be on the ballot in more than one county, the county clerks shall confer with one another and shall give the same ballot number or letter to the ballot issue or questions.
6. Each ballot question or issue shall contain the name of the political subdivision at the beginning of the ballot questions or issue. If the designated election official chooses, the name of the political subdivision may appear before the grouping of questions, such as State Ballot Questions, Arapahoe County Ballot Questions, City of Aurora Ballot Questions, etc.

6.4.3 General Provisions

- (a) The coordinated or designated election official may include the following statement with the ballot issue notice: "This notice is mailed to each address with one or more active, registered electors. You may not be eligible to vote on all issues presented in this notice."
- (b) The coordinated or designated election official may include the following statement on the ballot issue notice: "The following is a summary of comments filed in favor of, or opposed to, the ballot issue."

6.5 Colorado Constitution Article X, Section 20 notice requirements.

- 1 6.5.1 The state and local governments, excluding enterprises, have sole responsibility
2 for drafting and distribution of the notice required by Article X, Section 20. Any
3 or all of the responsibilities may be delegated to the coordinated election official
4 in the intergovernmental agreement.
- 5 6.5.2 The notice shall be mailed to “All Registered Voters” at the mailing addresses of
6 active registered electors in the county, as indicated on the voting record.
7 (a) Nothing shall preclude the coordinated or designated election official from
8 sending notice of various elections to persons who are not eligible electors
9 if the notice sent is part of the coordinated notice and if the sending arises
10 from the official’s efforts to mail the notice at “least cost”.
11 (b) Nothing shall preclude the coordinated or designated election official from
12 sending notice to each household in the county or political subdivision
13 whether or not registered electors reside at that household as long as notice
14 is sent which assures that all active registered electors are included on the
15 mailing list.
16 (c) Nothing shall preclude the coordinated or designated election official from
17 sending notice to each registered elector in a particular political
18 subdivision.
- 19 6.5.3 The coordinated election official must include information in the package sent
20 with the notice which tells electors whether the election is a mail ballot election, a
21 polling place election, a vote center election, or a combination of election forms.
22 (a) If the election is a polling place election or a vote center election, the
23 notice of the location of the polling place or vote center may be included
24 in the consolidated mailing.
25 (b) If a separate mail ballot election is being held by a political subdivision in
26 the county at the same time as a polling place election or a vote center
27 election, the notice shall include that information.
- 28 1-5-205 C.R.S.
- 29 6.5.4 If state statute allows the ballot issue notice and the ballot to be mailed at the
30 same time, the ballot for the mail ballot election may be included with the notice.
- 31 6.5.5 The political subdivisions must provide all completed Article X, Section 20
32 notices in camera ready format or as otherwise specified.
- 33 6.5.6 The coordinated election official shall not be responsible for failure to meet the
34 Article X, Section 20 constraints if the notice and summaries are not submitted by
35 the political subdivision within the deadline and in the form required by the
36 coordinated election official.
37 (a) The summaries of comments for and against ballot issues shall not include
38 language of a generally recognized profane, indecent, immoral, offensive,
39 scandalous or libelous character. No names of persons or private groups
40 shall be included in any summary.
41 (b) For purposes of counting words and to verify the five hundred
42 constitutional limit for each “pro” and each “con” summary, a hyphenated
43 word, unless it is divided by a continuation hyphen at the end of a line,
44 counts as two or more words. A number counts as one word, regardless of
45 dollar signs, commas, or periods within the number.

1 6.6 **If there is no candidate on the ballot for any particular office, the ballot shall read,**
2 **“No Candidate For This Office.”**
3

4 6.7 Written comments concerning ballot issues submitted to the designated election official
5 for the political subdivision shall not be withdrawn after the end of the business day on
6 the last Friday immediately preceding the forty-fifth day before the election. (*Note: Rule*
7 *duplicated in 10.3).*

8 **Rule 7. Rules Concerning Polling Places**

9 7.1 POLLING PLACE MATERIALS SHALL INCLUDE, WHERE APPLICABLE, HAVA INFORMATION,
10 VOTING DEMONSTRATION DISPLAY, SIGNATURE CARD TABLE, REGISTRATION RECORDS OR
11 LISTS, ELECTRONIC POLL BOOKS OR COMPLETED SIGNATURE CARDS, PAPER BALLOTS AND
12 VOTING BOOTHS OR DRE, PROVISIONAL VOTING AREA OR PROCEDURE, AND BALLOT BOX IF
13 PROVIDED.

14 7.2 For coordinated elections, polling places do not have to be within the political
15 subdivisions which are participating in the election.
16 *Note: No longer needed as explanation is found in C.R.S. 1-5-105(4) and 1-5-*
17 *504.5(a).*

18 7.3 Polling places for partisan elections must be established no less than ninety days prior to an
19 election and may only be changed pursuant to 1-5-108 IN THE EVENT OF an emergency or an
20 error in precincting.

21 7.4 In the event the polling place is to be in a temporary structure that is not present at the time, a
22 polling place notice is to be posted pursuant to 1-5-106, C.R.S., the future location of the
23 polling place shall nonetheless be posted at the required time, and notice shall continuously
24 remain posted until 48 hours after the polling place is closed.

25 ~~7.5 THE PROHIBITION ON ELECTIONEERING AND ELECTION RELATED ACTIVITIES WITHIN 100~~
26 ~~FEET OF THE BUILDING IN WHICH A POLLING PLACE IS LOCATED PER C.R.S. 1-5-105(1)~~
27 ~~EXTENDS TO THE LINE OF VOTERS WAITING TO VOTE OUTSIDE OF THE BUILDING IN WHICH~~
28 ~~THE POLLING PLACE IS LOCATED. SIGNS MAY BE POSTED OUTSIDE OF THE 100 FT. LIMIT,~~
29 ~~BUT ELECTION RELATED ACTIVITY OR INTERACTION IS NOT PERMITTED WITH THE VOTERS~~
30 ~~IN LINE OUTSIDE THE 100 FT LIMIT IS NOT PERMITTED.~~

31
32 **Rule 8. Rules Concerning Watchers**

33 8.1 Definitions:
34 8.1.1. “Official Observer” means either an observer appointed by the Secretary of State
35 or an observer appointed by the federal government and approved by the
36 Secretary of State. Official Observers may be present in all phases of the election
37 process, but are subject to rules and regulations as prescribed by the Secretary of
38 State, and perform duties as may be assigned by the Secretary of State.
39 8.1.2. “Watcher” shall mean an eligible elector other than a candidate on the ballot who
40 has been selected by a political party chairperson on behalf of the political party,
41 by a party candidate at a primary election, by an unaffiliated candidate at a
42 general, congressional vacancy, or nonpartisan election, or by a person designated
43 by either the opponents/proponents in the case of a ballot issue or ballot question.
44 If selected by a political party chairperson, a party candidate, or an unaffiliated
45 candidate, the watcher shall be affiliated with that political party or unaffiliated as

1 shown on the registration books of the county clerk and recorder. See 1-1-
2 104(51) C.R.S.

3 8.1.3. "Media Observer" shall mean an observer with valid and current media
4 credentials from the media who shall adhere to the formal document "Guidelines
5 for Members of the Media Who Observe Election Counts and Recounts" dated
6 June 2004, as may be amended, which are incorporated herein by this reference
7 for all proper purposes.

8 8.2 Qualification of Watchers. Watchers shall certify they are qualified pursuant to 1-1-
9 104(51), 1-7-105, 1-7-106, 1-7-107 and 1-7-108(2) C.R.S. Watchers shall take an oath as
10 provided in 1-7-108(1) and shall, upon first entering the precinct place or location,
11 surrender to the election official or election judges a certificate of appointment at each
12 precinct polling place or location where the watcher has been designated to act.

13 8.2.1 IF A WATCHER LEAVES A PRECINCT AND THE SAME WATCHER RETURNS LATER IN
14 THE DAY TO THE SAME PRECINCT, ANOTHER CERTIFICATE OF APPOINTMENT IS NOT
15 NECESSARY AND SHALL NOT BE REQUIRED. THE ORIGINAL CERTIFICATE OF
16 APPOINTMENT WILL SUFFICE.

17 8.2.2 IF A WATCHER IS REPLACED DURING THE DAY, THE WATCHER REPLACING THE
18 ORIGINAL WATCHER MUST HAVE AN ORIGINAL CERTIFICATE OF APPOINTMENT FOR
19 THAT PRECINCT.

20 8.2.3 CERTIFICATE OF APPOINTMENT AS A WATCHER IS NOT TRANSFERRABLE TO
21 ANOTHER INDIVIDUAL.

22 8.3 POLITICAL PARTY ATTORNEYS ARE NOT ALLOWED IN THE POLLING PLACE UNLESS THEY ARE
23 DULY APPOINTED AS WATCHERS.

24 8.4 WATCHERS ARE NOT ALLOWED TO HAVE CELL PHONES, CAMERAS, RECORDING DEVICES,
25 LAPTOPS OR PDAS (PALM PILOT, BLACKBERRY, ETC.) IN THE POLLING PLACE.

26 8.5 List of Eligible Electors. To assist Watchers in performing their tasks, the election
27 official or election judge shall provide a list, log, check-in card or other similar
28 information of voters who have appeared in the precinct polling place to vote. The
29 information or documents shall not be removed from the polling place or voting location.
30 Watchers may maintain a list of eligible electors who have voted by utilizing only that
31 information provided by the election official or election judge, except that they may bring
32 with them into the polling place or location a list of electors previously maintained by the
33 watcher. 1-7-108(3) C.R.S.

34 8.6 Watchers shall be subject to the provisions of 1-5-503 C.R.S.

35 8.7 What Watchers May Observe. Duly appointed Watchers may observe polling place
36 voting, early voting, and the processing and counting of precinct, provisional, mail, and
37 absentee ballots. For mail ballot elections, or absentee processing, watchers may be
38 present at each stage of the election including the receiving and bundling of the ballots
39 received by the designated election official. WATCHERS MAY BE PRESENT DURING
40 PROVISIONAL BALLOT PROCESSING BUT MAY NOT HAVE ACCESS TO CONFIDENTIAL VOTER
41 INFORMATION.

42 8.8 Limitations of Watchers. Duly appointed Watchers may observe election judges but may
43 not interrupt or disrupt the processing, verification, and counting of any ballots, or any
44 other stage of the election. Watchers may track the names of electors who have cast
45 ballots by utilizing their previously obtained lists, but may not write down any ballot
46 numbers or any other identifying information about the electors. Watchers may not

1 handle the poll books, official signature cards, ballots, mail ballot envelopes, absentee
2 ballot envelopes or provisional ballot envelopes, voting or counting machines or machine
3 components. Watchers shall not interfere with the orderly process and conduct of any
4 election, including ballot issuance, receiving of ballots, voting or counting of the ballots.
5 Watchers may not be allowed to interact with election officials or election judges, except
6 that each designated election official shall name at least one individual in each precinct
7 polling place or election location to whom watchers may direct questions or from whom
8 watchers may seek requested information.

9 8.9 Parties May Appoint Watchers. Major and minor political parties with candidates on the
10 ballot may appoint one Watcher each to be present to observe polling place voting, early
11 voting, and the processing and counting of regular, provisional, mail, and absentee
12 ballots. 1-7-105; 1-7-106 C.R.S.

13 8.10 Official Observers Appointed by the Federal Government. Official Observers appointed
14 by the federal government shall be approved by the Secretary of State and shall be
15 subject to Colorado law and these rules as they apply to Watchers; however, they need
16 not be eligible electors in the jurisdiction in which they act as Watchers. This Rule shall
17 not apply to Official Observers appointed by the United States Department of Justice.
18 Official Observers appointed by the Secretary of State shall be subject to the rules and
19 regulations as prescribed by the Secretary of State. Official Observers shall obtain from
20 the Secretary of State, or his or her designee, duly executed letters of authority. The
21 Official Observers shall surrender such letter of authority to the designated election
22 official in the jurisdiction in which they act as Watchers.

23 8.11 Watchers, Official Observers and Media Observers at a Recount. Watchers, Official
24 Observers and Media Observers may be present at a recount. Watchers, Official
25 Observers and Media Observers must be qualified and sworn for a recount in the same
26 manner as provided in Rule 8.2 and are subject to all other provisions related to the
27 recount process. Any political party, candidate involved in the recount, or proponents or
28 opponents of an issue or question involved in the recount may appoint one watcher to be
29 present at any time during the recount. The candidate who is subject to a recount may
30 appoint him or her self, or a member of the candidate's family by blood or marriage, as a
31 watcher at a recount. 1-7-105; 1-7-106 C.R.S.

32 8.12 Media Observers. Media Observers with valid and current media credentials may be
33 present to witness early voting, election day voting, and the processing and counting of
34 provisional, mail, and absentee ballots. However, at the discretion of the County Clerk
35 and Recorder, Media Observers may be required to appoint one member of the media as a
36 pool reporter, and one member as a pool photographer to represent all media observers in
37 accordance with the Guidelines established by the Colorado Press Association in
38 conjunction with the Colorado County Clerks' Associations and the Secretary of State as
39 set forth herein:
40 Guidelines for Member of the Media Who Observe Election Counts and Recounts (to be
41 distributed to members of the Colorado Press Association):
42 The Colorado State Association of County Clerks and Recorders, Colorado Broadcasters'
43 Association and Colorado Press Association have collaborated to develop the following
44 guidelines and protocols for use when members of the media observe the counting or
45 recounting of ballots. You are strongly encouraged to follow these guidelines to allow

1 meaningful media access while not disrupting the work of County Clerks to count ballots
2 or doing anything to compromise the integrity of the election process.

- 3 1. If practical, please contact the election official's office prior to coming to observe
4 the counting of ballots. If the election official knows you are coming, it will be
5 easier to accommodate your request for a place to observe the count or to
6 interview an election official.
 - 7 2. At the discretion of the election official, a specific viewing area for members of
8 the media and other observers may be available. To the extent practicable, the
9 area will have been designated with sight lines to allow you to observe and take
10 pictures or video of the counting process. If there are insufficient sight lines for
11 you to take the photos or video you need, the election official may be able to
12 make arrangements to accommodate your needs.
 - 13 3. Please observe counting procedures without disrupting the count. Please take
14 pictures or video without the use of supplemental lighting. Do not talk to people
15 participating in counting ballots. There may be workers who ask you not to
16 include their images in your pictures or video. We encourage you to honor those
17 requests if you can reasonably do so.
 - 18 4. The Secretary of State's election rules state that if observers leave the area during
19 a recount, they may not reenter without the consent of the election official. If you
20 have occasion to leave the area, you may be denied readmittance.
 - 21 5. Please do not use the information you see when observing vote counts to report on
22 partial election results. Please do not report anything that could be used to
23 identify the person who casts a particular ballot.
- 24 The Colorado State Association of County Clerks and Recorders, Colorado
25 Broadcasters' Association and Colorado Press Association are all committed to
26 working together to ensure the media has access to election counts and recounts,
27 but that access is afforded in manners that do not disrupt the counts and do
28 nothing to compromise the integrity of the process. Your cooperation in following
29 these standard will help us to meet all these goals.

30 8.13 Watchers at Vote Centers. To assist Watchers in performing their tasks when a vote
31 center election is held, the designated election official shall provide a list of all voters
32 who have appeared in the vote centers to vote. This list shall be made available at the
33 designated election official's main office. Such list may be made available to a
34 requesting Watcher(s) in the form of data files, paper, or reports, and furnished to all
35 interested parties via email, paper reports, or faxed copies as may be available to the
36 designated election official.

37 **Rule 9. Rules Concerning Assistance to Disabled Voters**

38 9.1 A sign providing substantially as follows shall be posted at the polling place/vote center:

39 NOTICE

40 VOTING ASSISTANCE FOR ELECTORS WITH DISABILITIES

41 Colorado law provides that a voter has a legal right to assistance in voting if assistance is
42 needed because of blindness or other physical disability or inability to read or write. The
43 following procedures apply:

- 44 1. The voter must inform one of the election judges that he or she needs assistance.
- 45 2. The voter may be assisted by any election judge or by any eligible elector selected
46 by the voter.

- 1 3. The person selected must complete a ‘voter assistance/disabled voter self-
 2 affirmation form’ if all of the following apply:
 3 • The person selected is not an election judge; and
 4 • The person selected is not the spouse, parent, grandparent, sibling, or
 5 child, eighteen years of age or older, of the voter requesting assistance;
 6 and
 7 • The person selected has assisted any other voter at the same election in the
 8 same precinct. 1-7-111(1)(b) C.R.S.
 9 • The self-affirmation form states, ‘I,, certify that I am the
 10 individual chosen by the disabled elector to assist the disabled elector in
 11 casting a ballot.’
 12 4. The person selected may provide any assistance needed by the voter, including
 13 entering the voting booth and preparing the ballot or operating the voting
 14 machine.
 15 5. The person providing assistance shall not seek to persuade or induce the voter to
 16 vote in a particular manner.
 17 6. The election judges shall record the name of each eligible elector assisted and the
 18 name of each person assisting by making an entry in the pollbook or list of
 19 eligible electors (or by making an entry on the signature card when preprinted
 20 signature cards are used in the place of a pollbook and list of eligible electors).
 21 9.2 When a voter has spoiled two ballots and requests a third ballot, an election judge shall
 22 offer assistance in voting procedures and casting the ballot.

23 **Rule 10. Rules Concerning Ballots and Election Supplies**

- 24 10.1 The text of all ballot issues that are subject to Article X, Section 20 shall be printed in all
 25 capital letters. The names of all candidates and all other ballot issues and questions shall
 26 be printed in upper and lower case.
 27 10.2 If a ballot has been printed in error, the designated election official shall consult, as soon
 28 as the error is discovered, with the Secretary of State and follow the direction of the Secretary of
 29 State on the appropriate method of correction.
 30 10.3 IF THERE IS NO CANDIDATE ON THE BALLOT FOR ANY PARTICULAR OFFICE, THE BALLOT
 31 SHALL READ, “NO CANDIDATE FOR THIS OFFICE.” ~~Note: Rule 6.6 relocated.~~
 32 10.4 ON OR AFTER JANUARY 1, 2006, POLITICAL ORGANIZATIONS OR INDIVIDUALS WHOSE
 33 CANDIDATE(S) NAMES ARE LISTED ON A BALLOT MUST PROVIDE AN AUDIO RECORDING OF
 34 THE PRONUNCIATION OF THE NAME TO THE SECRETARY OF STATE AT LEAST **SIXTY (60)**
 35 **DAYS** PRIOR TO THE ELECTION FOR OFFICES THAT ARE VOTED ON BY THE ELECTORS OF THE
 36 ENTIRE STATE, OR OF A CONGRESSIONAL DISTRICT, OR FOR THE OFFICES OF MEMBERS OF
 37 THE GENERAL ASSEMBLY OR DISTRICT ATTORNEY OR A DISTRICT OFFICE OF STATE
 38 CONCERN.

39 **RULE 11. RULES CONCERNING VOTING SYSTEMS**

- 40 11.1 DEFINITIONS (*Note: The definitions in section of Rule 11 were placed in alphabetical*
 41 *order; however, no substantive change was made to the July 25, 2005 draft).*
 42 11.1.1 "VOTING SYSTEM" MEANS A SYSTEM THAT FACILITATES THE PROCESS OF CASTING,
 43 RECORDING, AND TABULATING VOTES USING ELECTROMECHANICAL OR ELECTRONIC
 44 DEVICES OR BALLOT CARDS AND INCLUDES, BUT IS NOT LIMITED TO, THE
 45 PROCEDURES FOR CASTING AND PROCESSING VOTES AND THE OPERATING MANUALS,

1 HARDWARE, FIRMWARE, PRINTOUTS, AND SOFTWARE NECESSARY TO OPERATE THE
2 VOTING SYSTEM.

3 11.1.2 "VOTING SYSTEM PROVIDER" MEANS AN INDIVIDUAL ENGAGED IN PRIVATE
4 ENTERPRISE OR A BUSINESS ENTITY ENGAGED IN SELLING, LEASING, MARKETING,
5 DESIGNING, BUILDING, OR MODIFYING VOTING SYSTEMS TO THE STATE, A POLITICAL
6 SUBDIVISION OF THE STATE, OR ANOTHER ENTITY AUTHORIZED TO HOLD AN
7 ELECTION UNDER TITLE 1 OF THE COLORADO REVISED STATUTES.

8 11.1.3 "ELECTROMECHANICAL VOTING SYSTEM" MEANS A SYSTEM IN WHICH AN ELECTOR
9 VOTES USING A DEVICE FOR MARKING A PAPER BALLOT USING INK OR ANOTHER
10 VISIBLE SUBSTANCE AND THE VOTES ARE COUNTED WITH ELECTRONIC VOTE-
11 TABULATING EQUIPMENT, OR A SYSTEM IN WHICH VOTES ARE DIRECTLY RECORDED
12 ELECTRONICALLY WITHIN THE EQUIPMENT ON PAPER TAPE AND ARE RECORDED
13 SIMULTANEOUSLY ON AN ELECTRONIC DEVICE THAT PERMITS TABULATION AT A
14 COUNTING CENTER.

15 11.1.4 "ELECTRONIC VOTE-TABULATING EQUIPMENT" OR "ELECTRONIC VOTE-COUNTING
16 EQUIPMENT" MEANS ANY APPARATUS THAT EXAMINES AND RECORDS VOTES
17 AUTOMATICALLY AND TABULATES THE RESULT, INCLUDING BUT NOT LIMITED TO
18 OPTICAL SCANNING EQUIPMENT. THE TERM INCLUDES ANY APPARATUS THAT
19 COUNTS VOTES ELECTRONICALLY AND TABULATES THE RESULTS SIMULTANEOUSLY
20 ON A PAPER TAPE WITHIN THE APPARATUS, THAT USES AN ELECTRONIC DEVICE TO
21 STORE THE TABULATION RESULTS, AND THAT HAS THE CAPABILITY TO TRANSMIT
22 THE VOTES INTO A CENTRAL PROCESSING UNIT FOR PURPOSES OF A PRINTOUT AND
23 AN OFFICIAL COUNT.

24 11.1.5 "ELECTRONIC VOTING DEVICE" MEANS A DEVICE BY WHICH VOTES ARE RECORDED
25 ELECTRONICALLY, INCLUDING A TOUCH SCREEN SYSTEM.

26 11.1.6 "ELECTRONIC BALLOT" MEANS A BALLOT THAT IS PRESENTED TO THE VOTER IN A
27 NON-PAPER FORM SUCH AS ON A TOUCH SCREEN OR THROUGH AUDIO FEEDBACK.
28 AFTER A VOTER CASTS AN ELECTRONIC BALLOT, THE VOTER'S CHOICES MAY BE:

- 29 • MARKED AND PRINTED ON A PAPER BALLOT FOR SUBSEQUENT COUNTING BY A
30 PAPER BALLOT SCANNING DEVICE; OR
- 31 • DIGITALLY RECORDED AND COUNTED BY THE TOUCH SCREEN DEVICE,
32 COMMONLY REFERRED TO AS A DIRECT RECORD ELECTRONIC (DRE) DEVICE.

33 11.1.7 "CENTRAL COUNT" MEANS A BALLOT COUNTING PROCESS WHEREBY CUMULATIVE
34 VOTING TOTALS ARE TABULATED FOR MULTIPLE PRECINCTS AND MULTIPLE BALLOT
35 STYLES.

36 11.1.8 "VOTE CENTER COUNT" MEANS A BALLOT COUNTING PROCESS WHEREBY
37 CUMULATIVE VOTING TOTALS ARE TABULATED FOR MULTIPLE PRECINCTS AND
38 MULTIPLE BALLOT STYLES AT MULTIPLE LOCATIONS.

39 11.1.9 "PRECINCT COUNT" MEANS A BALLOT COUNTING PROCESS WHEREBY VOTING
40 TOTALS ARE TABULATED FOR SINGLE/MULTIPLE PRECINCTS AND MULTIPLE BALLOT
41 STYLES AT INDIVIDUAL POLLING PLACE LOCATIONS.

42 11.1.10 "SECURE" AS DEFINED IN 1-7-505 C.R.S. MEANS ANY METHODS OF PREVENTING
43 THE USE OF THE VOTING EQUIPMENT PRIOR TO AND AFTER ALL LEGAL VOTES ARE
44 CAST.

45 11.1.11 "LOGIC AND ACCURACY TEST (LAT)" MEANS A STEP BY STEP DOCUMENTED
46 REVIEW OF A VOTING DEVICE'S ABILITY, PRIOR TO USE IN ANY ELECTION, TO

- 1 PRODUCE ACCURATE RESULTS ON VOTER CHOICES FOR THE CANDIDATES AND
2 BALLOT ISSUES IN AN ELECTION. THE LOGIC AN ACCURACY TEST SHALL FULFILL
3 THE REQUIREMENTS IDENTIFIED AS PUBLIC TEST AS IDENTIFIED IN 1-7-509(2)
4 C.R.S.
- 5 11.1.12 "FIRMWARE" MEANS COMPUTER PROGRAMS, STORED ON READ-ONLY MEMORY
6 DEVICES OR OTHER ELECTRONIC CIRCUITRY IN VOTING DEVICES, THAT CONTROL
7 THE BASIC OPERATIONS AND FUNCTIONING OF THOSE DEVICES.
- 8 11.1.13 "ZERO TAPE" MEANS A PRINTOUT OF THE INTERNAL DATA REGISTERS IN
9 ELECTRONIC VOTE-TABULATING EQUIPMENT INDICATING THAT THOSE REGISTERS
10 CONTAIN VALUES OF "ZERO (0)" AND REFLECT NO VOTER CHOICES FOR ANY
11 CANDIDATE OR BALLOT ISSUE.
- 12 11.1.14 "ELECTION SETUP RECORDS" MEANS THE ELECTRONIC RECORDS GENERATED BY
13 ELECTION TABULATION SOFTWARE DURING ELECTION SETUP TO CREATE AND
14 DEFINE BALLOTS, TABULATION INSTRUCTIONS, AND OTHER FUNCTIONS RELATED TO
15 THE ELECTION.
- 16 11.1.15 "ELECTION SOFTWARE" MEANS THE SOFTWARE TO BE INSTALLED OR RESIDING ON
17 ELECTION EQUIPMENT FIRMWARE OR ON ELECTION MANAGEMENT COMPUTERS THAT
18 CONTROLS ELECTION SETUP, VOTE RECORDING, VOTE TABULATION AND REPORTING.
- 19 11.2 VOTING SYSTEM ACCESS
- 20 11.2.1 THE COUNTY CLERK AND RECORDER SHALL NOT PROGRAM OR OPERATE THE
21 VOTING SYSTEM SUBJECT TO 1-5-607 C.R.S.
- 22 11.2.2 ANY ELECTION SETUP MATERIALS SHALL BE STORED BY THE COUNTY CLERK AND
23 RECORDER UNDER SECURITY WITH ACCESS LIMITED TO THE PERSON OR PERSONS SO
24 AUTHORIZED IN WRITING BY THE COUNTY CLERK AND RECORDER.
- 25 11.2.3 EMPLOYEES OF THE COUNTY CLERK AND RECORDER WHO ARE AUTHORIZED BY THE
26 COUNTY CLERK AND RECORDER TO PREPARE OR MAINTAIN THE VOTING SYSTEM OR
27 ELECTION SETUP MATERIALS SHALL BE DEPUTIZED **BY THE COUNTY CLERK AND**
28 **RECORDER** FOR THIS SPECIFIC PURPOSE AND SO SWORN PRIOR TO **THE FIRST**
29 **ELECTION OF THE CALENDAR YEAR** IN WHICH THEY WILL BE PERFORMING ONE OR
30 MORE OF THESE ACTIVITIES.
- 31 11.2.4 THE COUNTY CLERK AND RECORDER SHALL REQUEST AN INTERNET CRIMINAL
32 HISTORY CHECK (IHC) FROM THE COLORADO BUREAU OF INVESTIGATION (CBI)
33 FOR ALL FULL-TIME, PART-TIME, PERMANENT AND CONTRACT EMPLOYEES OF THE
34 COUNTY WHO STAFF THE COUNTING CENTER AND WHO HAVE ANY ACCESS TO
35 ELECTROMECHANICAL VOTING SYSTEMS OR ELECTRONIC VOTE TABULATING
36 EQUIPMENT. AT THE DIRECTION OF THE COUNTY CLERK AND RECORDER, AN IHC
37 CHECK MAY BE CONDUCT ON ELECTION JUDGES. THE COUNTY CLERK AND
38 RECORDER SHALL REQUEST THE IHC ONCE PER CALENDAR YEAR FOR SUCH
39 EMPLOYEES PRIOR TO THE FIRST ELECTION OF THE YEAR.
- 40 11.2.5 IF THE IHC INDICATES THAT THE EMPLOYEE OR CONTRACT EMPLOYEE HAS BEEN
41 FOUND GUILTY OF A CRIME INVOLVING BREACH OF TRUST, FRAUDULENT, COERCIVE,
42 OR DISHONEST PRACTICES OR DEMONSTRATING INCOMPETENCE,
43 UNTRUSTWORTHINESS, OR AN ELECTION OFFENSES PURSUANT TO 1-13-101 *ET SEQ.*
44 C.R.S., THE COUNTY CLERK AND RECORDER SHALL PROHIBIT SUCH EMPLOYEE OR
45 CONTRACT EMPLOYEE FROM PREPARING, PROGRAMMING, OPERATING, USING OR
46 HAVING ANY ACCESS WHATSOEVER TO ELECTROMECHANICAL VOTING SYSTEMS OR

1 ELECTRONIC VOTE TABULATING EQUIPMENT AT ANY TIME DURING THAT PERSON'S
2 EMPLOYMENT.

3 11.2.6 VENDORS SHALL PROVIDE A CRIMINAL HISTORY CHECK TO THE COUNTY CLERK AND
4 RECORDER FOR ANY EMPLOYEE OF THE VENDOR WHO HAS ANY ACCESS TO
5 ELECTROMECHANICAL VOTING SYSTEMS OR ELECTRONIC VOTE TABULATING
6 EQUIPMENT. THE VENDOR SHALL PROVIDE THE CRIMINAL HISTORY CHECK TO THE
7 COUNTY CLERK AND RECORDER ONCE PER CALENDAR YEAR FOR SUCH EMPLOYEES
8 PRIOR TO THE FIRST ELECTION OF THE YEAR.

9 11.3 PERFORMANCE BOND

10 11.3.1 EFFECTIVE UPON THE DATE OF THE ADOPTION OF THIS RULE, A VOTING SYSTEM
11 PROVIDER THAT PROVIDES VOTING SYSTEMS OR A SERVICE PROVIDER THAT
12 PROVIDES ELECTION SETUP OR TABULATION SERVICES TO ONE OR MORE COUNTIES
13 SHALL:

14 (A) PROVIDE THE SERVICES BY WRITTEN CONTRACT, A COPY OF WHICH SHALL BE
15 KEPT ON FILE WITH THE COUNTY CLERK AND RECORDER AND THE SECRETARY
16 OF STATE;

17 (B) POST A PERFORMANCE BOND, EXECUTED BY A CORPORATE SURETY LICENSED
18 TO TRANSACT BUSINESS IN THE STATE OF COLORADO. THE COUNTY UNDER
19 CONTRACTUAL OBLIGATION WITH THE VOTING SYSTEM PROVIDER OR
20 SERVICE PROVIDER THAT PROVIDES ELECTION SETUP OR TABULATION
21 SERVICES SHALL BE DESIGNATED AS THE BENEFICIARY OF THE BOND; AND

22 (C) PROVIDE PROOF THAT A PERFORMANCE BOND HAS BEEN POSTED WITH THE
23 SECRETARY OF STATE AND THE OFFICE OF THE DESIGNATED ELECTION
24 OFFICIAL. THE AMOUNT OF THE BOND SHALL BE THE GREATER OF EITHER
25 \$10,000 OR **THE FULL AMOUNT OF THE CONTRACT WITH THE BENEFICIARY**
26 **COUNTY,**

27 11.3.2 THE VOTING SYSTEM PROVIDER SHALL UPDATE ALL BOND DOCUMENTS FOR EACH
28 CONTRACT OR ELECTION PERFORMED.

29 11.4 VOTING SYSTEM INVENTORY

30 11.4.1 THE DESIGNATED ELECTION OFFICIAL SHALL MAINTAIN AN INVENTORY RECORD FOR
31 EACH ELECTRONIC VOTE-TABULATING DEVICE USED IN AN ELECTION. SUCH
32 RECORDS SHALL INCLUDE, BUT NOT BE LIMITED TO, THE MANUFACTURER, MAKE,
33 MODEL, SERIAL NUMBER, HARDWARE/FIRMWARE/SOFTWARE VERSION OR RELEASE
34 NUMBER, DATE OF ACQUISITION, DESCRIPTION OF ANY SERVICES, REPAIRS,
35 MAINTENANCE, UPKEEP, AND VERSION UPGRADES, AND DATE OF PERFORMANCE OF
36 SUCH SERVICES AS OF THE DATE OF ADOPTION OF THESE RULES.

37 11.4.2 THE DESIGNATED ELECTION OFFICIAL SHALL FURNISH THE SECRETARY OF STATE
38 WITH AN EXTRACT OR COPY OF THE INVENTORY FOR USE IN THE LOGIC AND
39 ACCURACY TEST AND THE POST-ELECTION AUDIT TEST. THE REQUIREMENTS FOR
40 THIS EXTRACT ARE:

41 (A) BE IN EITHER ELECTRONIC OR PAPER FORMAT;

42 (B) CONTAIN INFORMATION REGARDING: MAKE, MODEL, SERIAL NUMBER, TYPE
43 (OPTICAL SCANNER OR DRE), SPECIFIC LOCATION OF USE, AND SPECIFIC
44 PRECINCTS PROGRAMMED OF EACH DEVICE;

45 (C) INVENTORIES MAINTAINED IN ELECTRONIC FORMAT SHALL BE EXPORTABLE
46 TO AN INDUSTRY STANDARD FILE TYPE – COMMA SEPARATED (CSV), EXCEL

SPREADSHEET (XLS), OR QUOTE OR TAB SEPARATED (TXT) FILE PRIOR TO ELECTRONIC DELIVERY TO THE SECRETARY OF STATE; AND
(D) THE DESIGNATED ELECTION OFFICIAL SHALL SEND THE INVENTORY LIST TO THE SECRETARY OF STATE'S OFFICE NOT LESS THAN TEN (10) DAYS PRIOR TO AN ELECTION TO THE ATTENTION OF THE VOTING SYSTEMS SPECIALIST. INVENTORY LISTS MAY BE SENT IN ONE OF THREE MEANS:
E-MAIL: VOTING.SYSTEMS@SOS.STATE.CO.US SUBJECT LINE = COUNTY NUMBER, COUNTY NAME, HARDWARE INVENTORY LIST; OR
VIA FACSIMILE TO: 303-869-4861 ATTN: SECRETARY OF STATE, VOTING SYSTEMS SPECIALIST; OR VIA FIRST CLASS MAIL TO COLORADO DEPARTMENT OF STATE/ ATTN: VOTING SYSTEMS SPECIALIST/1700 BROADWAY – SUITE 270/DENVER, CO 80290.

11.5 VOTING SYSTEM TESTING

11.5.1 THREE TYPES OF VOTING SYSTEM TESTING SHALL BE PERFORMED FOR EACH ELECTION WITHIN A JURISDICTION. THE THREE TESTS ARE:

- A HARDWARE DIAGNOSTIC TEST;
- A LOGIC AND ACCURACY TEST (LAT); AND,
- A POST-ELECTION AUDIT TEST.

11.5.2 HARDWARE DIAGNOSTIC TEST

THE COUNTY CLERK AND RECORDER SHALL COMMENCE THE HARDWARE DIAGNOSTIC TEST PRIOR TO THE ELECTION AND ALLOW TIME FOR EACH ELECTRONIC VOTING DEVICE WITHIN THE COUNTY TO BE TESTED. EACH DEVICE SHALL BE TESTED TO VERIFY MECHANICAL COMPONENTS ARE WORKING CORRECTLY. THIS TEST SHALL INCLUDE, BUT NOT BE LIMITED TO, THE FOLLOWING TESTS:

- (a) ALL INPUT AND OUTPUT DEVICES;
- (b) COMMUNICATIONS PORTS;
- (c) SYSTEM PRINTERS;
- (d) SYSTEM MODEMS WHEN APPLICABLE;
- (e) SYSTEM SCREEN DISPLAYS;
- (f) BOOT PERFORMANCE AND INITIALIZATIONS;
- (g) FIRMWARE LOADS;
- (h) SOFTWARE LOADS;
- (i) CONFIRMATION THAT SCREEN DISPLAYS ARE FUNCTIONING; AND
- (j) DATE, TIME AND CALIBRATION OF SYSTEMS.

11.5.3 LOGIC AND ACCURACY TEST

THE DESIGNATED ELECTION OFFICIAL SHALL CONDUCT A LOGIC AND ACCURACY TEST ACCORDING TO THE FOLLOWING REQUIREMENTS.

~~(a)~~ 11.5.3.1 THE DESIGNATED ELECTION OFFICIAL SHALL CREATE A TESTING BOARD CONSISTING OF AT LEAST TWO PERSONS, ONE FROM EACH MAJOR POLITICAL PARTY.

~~(b)~~ 11.5.3.2 PRIOR TO THE COMMENCEMENT OF VOTING, THE DESIGNATED ELECTION OFFICIAL SHALL CONDUCT THE PUBLIC LOGIC AND ACCURACY TEST.

~~(c)~~ 11.5.3.3 THE LOGIC AND ACCURACY TEST SHALL BE OPEN TO REPRESENTATIVES OF THE PRESS AND THE PUBLIC TO THE EXTENT ALLOWABLE AND 1-7-509(2)(B) C.R.S. THE DESIGNATED ELECTION OFFICIAL MAY LIMIT THE NUMBER OF

Formatted: Bullets and Numbering

1 REPRESENTATIVES FROM EACH GROUP TO ACCOMMODATE FOR SPACE LIMITATIONS
2 AND OTHER CONSIDERATIONS.

3 ~~(e)~~11.5.3.4 TESTING BOARD TEST BALLOTS – IN PREPARATION FOR THE LOGIC
4 AND ACCURACY TEST, THE DESIGNATED ELECTION OFFICIAL SHALL PROVIDE TO
5 EACH MEMBER OF THE TESTING BOARD , AT LEAST TWENTY-FIVE (25) BALLOTS
6 THAT ARE CLEARLY MARKED AS TEST BALLOTS TO BE USED FOR THE LOGIC AND
7 ACCURACY TEST.

8 ~~(e)~~11.5.3.5 THE MEMBERS OF THE TESTING BOARD SHALL SECRETLY VOTE THEIR
9 POSITION AND RETAIN A RECORD OF THE TALLY OF THEIR TEST VOTES. THE TEST
10 BALLOTS SHALL HAVE A KNOWN PREDETERMINED OUTCOME BY THE MEMBERS OF
11 THE TESTING BOARD’S SECRET VOTE AND TALLY. OF THE TWENTY-FIVE TEST
12 BALLOTS, TWO SHALL BE TESTED AS AUDIO BALLOTS WHERE APPLICABLE.

13 ~~(e)~~11.5.3.6 COUNTY TEST BALLOTS – IN PREPARATION FOR THE LOGIC AND
14 ACCURACY TEST, THE DESIGNATED ELECTION OFFICIAL SHALL PREPARE A
15 SUFFICIENT NUMBER OF TEST BALLOTS THAT REPRESENT EVERY BALLOT STYLE,
16 EVERY PRECINCT, ALLOW FOR A SUFFICIENT NUMBER OF BALLOTS TO MARK EVERY
17 VOTE POSITION FOR EVERY CANDIDATE ON EVERY RACE, ALLOW FOR SITUATIONS
18 WHERE A RACE MAY ALLOW FOR AN ELECTOR TO VOTE FOR TWO OR MORE
19 POSITIONS, AND INCLUDE OVERVOTES AND UNDERVOTES FOR EACH RACE.

20 ~~(e)~~11.5.3.7 THE TEST BALLOTS SHALL BE TESTED ON EACH TYPE OF VOTING DEVICE
21 UTILIZED IN A GIVEN ELECTION, AND EACH METHOD OF COUNTING. THE TESTS
22 SHALL INCLUDE TESTING OF ABSENTEE COUNTING METHODS, ELECTION DAY
23 COUNTING METHODS, PROVISIONAL BALLOT COUNTING METHODS, EARLY VOTING
24 COUNTING METHODS AND AUDIO BALLOTS, IF APPLICABLE.

25 ~~(h)~~11.5.3.8 CONDUCTING THE TEST

26 ~~(4)~~11.5.3.8.1 THE DESIGNATED ELECTION OFFICIAL AND TESTING BOARD
27 SHALL OBSERVE THE TABULATION OF ALL TEST BALLOTS BY MEANS OF THE
28 VOTING DEVICE AND COMPARE THE TABULATION WITH THE PREVIOUSLY
29 RETAINED RECORDS OF THE TEST VOTE COUNT. THE CAUSE OF ANY
30 DISCREPANCIES SHALL BE CORRECTED PRIOR TO THE START OF VOTE
31 TABULATION.

32 ~~(2)~~11.5.3.8.2 PRIOR TO THE START OF TESTING, ALL DEVICES USED WILL
33 HAVE THE PUBLIC COUNTER RESET TO ZERO, AND PRESENTED TO THE TESTING
34 BOARD FOR VERIFICATION.

35 ~~(3)~~11.5.3.8.3 AN APPROPRIATE NUMBER OF VOTING DEVICES WILL BE
36 AVAILABLE AND THE TESTING BOARD MAY WITNESS THE NECESSARY
37 PROGRAMMING AND/OR DOWNLOADING OF MEMORY DEVICES NECESSARY TO
38 TEST THE SPECIFIC PRECINCTS.

39 ~~(4)~~11.5.3.8.4 THE TESTING BOARD, DESIGNATED ELECTION OFFICIAL OR HIS
40 OR HER DESIGNATED DEPUTIZED CLERKS AS NECESSARY SHALL COUNT THE
41 TEST BALLOTS AS FOLLOWS:

42 ~~(A)~~ ABSENTEE BALLOTS:

43 ~~(1)~~ — ALL COUNTY TEST BALLOTS SHALL BE COUNTED ON AT
44 LEAST ONE, BUT NOT MORE THAN THREE, ABSENTEE VOTE COUNTING
45 DEVICES AND HAVE THE PREDETERMINED TOTAL VERIFIED TO THE
46 MACHINE TOTAL.

1 |
2 |
3 |
4 |
5 |
6 |
7 |
8 |
9 |
10 |
11 |
12 |
13 |
14 |
15 |
16 |
17 |
18 |
19 |
20 |
21 |
22 |
23 |
24 |
25 |
26 |
27 |
28 |
29 |
30 |
31 |
32 |
33 |
34 |
35 |
36 |
37 |
38 |
39 |
40 |
41 |
42 |
43 |
44 |
45 |
46 |

~~o(2)~~—ALL TESTING BOARD MEMBER TEST BALLOTS SHALL BE COUNTED INDIVIDUALLY WITH REPORTS GENERATED TO VERIFY THE MACHINE COUNT TO THE PREDETERMINED HAND TALLY.

~~(B)~~ PRECINCT BALLOTS (OPTICAL SCAN AND DRE):

~~o(1)~~—THE TESTING BOARD SHALL RANDOMLY SELECT 20% BUT NOT MORE THAN 10 BALLOTS REPRESENTING UNIQUE PRECINCTS FROM THE TESTING BOARD’S TEST BALLOTS.

~~o(2)~~—IN THE EVENT A SELECTED PRECINCT CONTAINS A COMBINATION OF DRE AND OPTICAL SCAN VOTING DEVICES, THE TESTING BOARD SHALL DECIDE ON THE PERCENTAGE OF BALLOTS TO BE COUNTED ON EACH TYPE OF DEVICE USED FOR THAT PRECINCT.

~~o(3)~~—THE PRECINCT SPECIFIC COUNTY TEST BALLOTS WILL BE ADDED TO THE TESTING BOARD TEST BALLOTS TO BE COUNTED ON THE SPECIFIC PRECINCT DEVICE. THE TESTING BOARD SHALL MANUALLY VERIFY THE BALLOTS TO BE COUNTED PRIOR TO ANY MACHINE COUNT.

~~o(4)~~—THE TESTING BOARD SHALL VERIFY THE MANUAL COUNT TO THE VOTING DEVICE COUNT.

~~(C)~~ EARLY VOTING AND PROVISIONAL BALLOTS ~~C~~OUNTED ON OPTICAL SCAN DEVICES:

~~o(1)~~—ALL TEST BALLOTS SHALL BE COUNTED ON AT LEAST ONE, BUT NOT MORE THAN FIVE, OPTICAL SCAN DEVICES AND HAVE THE PREDETERMINED TOTAL VERIFIED TO THE MACHINE TOTAL.

~~o(2)~~—ALL BALLOTS SHALL BE COUNTED INDIVIDUALLY WITH REPORTS GENERATED TO VERIFY THE MACHINE COUNT TO THE PREDETERMINED TALLY OF THE TEST BALLOTS.

~~(D)~~ EARLY VOTING AND PROVISIONAL BALLOTS COUNTED ON DRE’S:

~~o(1)~~—**ALL TEST BALLOTS SHALL BE COUNTED ON AT LEAST ONE, BUT NOT MORE THAN FIVE, OPTICAL SCAN DEVICES AND HAVE THE PREDETERMINED TOTAL VERIFIED TO THE MACHINE TOTAL.**

~~o(2)~~—ALL TESTING BOARD MEMBER TEST BALLOTS SHALL BE COUNTED INDIVIDUALLY WITH REPORTS GENERATED TO VERIFY THE MACHINE COUNT TO THE PREDETERMINED TALLY OF THE TESTING BOARD TEST BALLOTS.

~~(E)~~ AUDIO BALLOTS COUNTED ON DRE’S:

~~o(1)~~—TWO OF THE TESTING BOARD BALLOTS SHALL BE IDENTIFIED AS AUDIO BALLOTS TO BE TESTED AS SUCH AND INCLUDED WITH THE COUNT.

~~(F)~~ ALL TEST MATERIALS, WHEN NOT IN USE, SHALL BE KEPT IN A METAL BOX WITH INDIVIDUAL SEALS FOR EACH MEMBER OF THE TESTING BOARD. THE DESIGNATED ELECTION OFFICIAL MAY AFFIX HIS OR HER OWN SEAL IN ADDITION TO THOSE OF THE TESTING BOARD. THE DESIGNATED ELECTION OFFICIAL SHALL BE THE CUSTODIAN OF THE BOX OR BOXES BUT SHALL NOT OPEN AND/OR USE THE TEST MATERIALS OUTSIDE OF THE PRESENCE OF THE TESTING BOARD.

~~(G)~~ THE TESTING BOARD AND THE DESIGNATED ELECTION OFFICIAL SHALL SIGN A WRITTEN STATEMENT ATTESTING TO THE QUALIFICATION OF EACH DEVICE THAT WAS

Formatted: Bullets and Numbering

Formatted: Bullets and Numbering

1 SUCCESSFULLY TESTED, THE NUMBER OF THE SEAL ATTACHED TO THE VOTING DEVICE AT
2 THE END OF THE TEST, ANY PROBLEMS DISCOVERED, AND PROVIDE ANY OTHER
3 DOCUMENTATION AS NECESSARY TO PROVIDE A FULL AND ACCURATE ACCOUNT OF THE
4 CONDITION OF A GIVEN DEVICE.

5
6 ~~(h)~~ UPON COMPLETION OF THE TESTING, THE TESTING BOARD SHALL WITNESS THE
7 RESETTING AND SEALING OF EACH TESTED VOTING DEVICE.

Formatted: Bullets and Numbering

8
9 11.5.4 POST-ELECTION AUDIT

10 ~~(h)~~ 11.5.4.1 WITHIN TWENTY-FOUR (24) HOURS OF THE CLOSE OF POLLS ON
11 ELECTION NIGHT, THE SECRETARY OF STATE SHALL NOTIFY THE DESIGNATED
12 ELECTION OFFICIAL WHICH VOTING DEVICES AND WHICH RACE OR RACES ON THE
13 BALLOTS HAVE BEEN SELECTED FOR AUDITING PURPOSES BASED ON THE SUBMITTED
14 HARDWARE INVENTORY LIST REFERRED TO IN RULE 11.4.2.

Formatted: Bullets and Numbering

15 ~~(h)~~ 11.5.4.2 THE SELECTION OF EQUIPMENT WILL BE BASED ON A RANDOM
16 SELECTION OF ONE (1) PERCENT OF PRECINCT SCANNER BASED VOTING EQUIPMENT,
17 AT LEAST ONE CENTRAL COUNT SCANNER/VOTE CENTER, AND ONE (1) PERCENT OF
18 DIRECT RECORD ELECTRONIC (DRE) VOTING DEVICES.

19 ~~(h)~~ 11.5.4.3 FOR OPTICAL SCANNERS USED FOR ANY FUNCTION OF COUNTING
20 BALLOTS EXCEPT FOR CENTRAL COUNT/VOTE CENTER AS DEFINED HEREIN, THE
21 DESIGNATED ELECTION OFFICIAL SHALL MANUALLY VERIFY ALL OF THE BALLOTS
22 THAT WERE COUNTED ON THE RANDOMLY SELECTED DEVICE(S) WITH THE ELECTION
23 SUMMARY REPORT THAT WAS GENERATED FROM THE DEVICE(S) AT THE CLOSE OF
24 THE POLLS. THE SECRETARY OF STATE SHALL RANDOMLY SELECT TWO RACES TO
25 BE MANUALLY VERIFIED.

26 ~~(h)~~ 11.5.4.4 FOR OPTICAL SCANNERS USED FOR THE PURPOSE OF COUNTING
27 BALLOTS IN A CENTRAL COUNT/VOTE CENTER ENVIRONMENT AS DEFINED HEREIN,
28 THE DESIGNATED ELECTION OFFICIAL SHALL RANDOMLY SELECT ONE (1) PERCENT
29 BUT NOT MORE THAN ONE HUNDRED (100) BALLOTS OF ALL THE BALLOTS COUNTED
30 ON THE SPECIFIC AUDITED DEVICE. IF THE AMOUNT OF BALLOTS IS LESS THAN ONE
31 HUNDRED (100) ON THE AUDITED DEVICE, THEN ALL OF THE BALLOTS WILL BE
32 MANUALLY VERIFIED. THE PUBLIC COUNTER FOR THAT VOTING DEVICE SHALL BE
33 RESET TO ZERO, AND THE BALLOTS SHALL BE RECOUNTED ON THE VOTING DEVICE.
34 A NEW REPORT WILL BE GENERATED FROM THE ELECTRONIC COUNT OF THE
35 BALLOTS AND SHALL BE MANUALLY VERIFIED. THE BALLOTS AND A COPY OF THE
36 REPORT SHALL BE SEALED IN A SEPARATE CONTAINER AND SECURED WITH THE
37 REMAINDER OF THE OFFICIAL ELECTION RECORDS FOR THE ELECTION. THE
38 SECRETARY OF STATE SHALL RANDOMLY SELECT TWO RACES TO BE MANUALLY
39 VERIFIED.

40 ~~(h)~~ 11.5.4.5 FOR DIRECT RECORD ELECTRONIC DEVICES (DRE) THAT DO NOT MEET
41 THE REQUIREMENTS OF 1-5-802 C.R.S. USED FOR ANY FUNCTION OF COUNTING
42 BALLOTS IN AN ELECTION, THE DESIGNATED ELECTION OFFICIAL WILL MANUALLY
43 VERIFY THE IMAGE OF ALL THE BALLOTS CONTAINED IN THE BALLOT LOG OR
44 BALLOT AUDIT THAT WERE COUNTED ON THE SPECIFIC DEVICE WITH THE REPORT
45 GENERATED FOR THAT SPECIFIC DEVICE AT THE CLOSE OF POLLS WHICH CONTAINS

1 THE ELECTION SUMMARY REPORT. THE SECRETARY OF STATE SHALL RANDOMLY
2 SELECT TWO RACES TO BE MANUALLY VERIFIED.

3 ~~(e)~~11.5.4.6 FOR DIRECT RECORD ELECTRONIC DEVICES (DRE) THAT DO MEET THE
4 REQUIREMENTS OF 1-5-802 C.R.S. USED FOR ANY FUNCTION OF COUNTING BALLOTS
5 IN AN ELECTION, THE DESIGNATED ELECTION OFFICIAL WILL MANUALLY VERIFY ALL
6 OF THE VOTER VERIFIED PAPER RECORDS PRODUCED WITH THE REPORT GENERATED
7 FOR THAT SPECIFIC DEVICE AT THE CLOSE OF POLLS WHICH CONTAINS THE ELECTION
8 SUMMARY REPORT. THE SECRETARY OF STATE SHALL RANDOMLY SELECT TWO
9 RACES TO BE MANUALLY VERIFIED.

10 ~~(e)~~11.5.4.7 THE ACTIONS OF THE RANDOM AUDIT AS IDENTIFIED IN THIS SECTION
11 ARE TO BE OBSERVED BY AT LEAST TWO MEMBERS OF THE CANVASS BOARD. THE
12 DESIGNATED ELECTION OFFICIAL MAY APPOINT ADDITIONAL DEPUTIZED CLERKS TO
13 ASSIST IN THE FUNCTIONS OF THE AUDIT.

14 ~~(h)~~11.5.4.8 IF THERE ARE DISCREPANCIES IN THE AUDIT, THE CANVASS BOARD OR
15 ITS DEPUTIZED CLERKS SHALL:

16 ~~11.5.4.8.1~~ — FIRST, MANUALLY VERIFY THE RESULTS AS MANY TIMES AS
17 NECESSARY TO CONFIRM THAT THERE IS NO DISCREPANCY IN THE MANUAL
18 COUNT;

19 ~~11.5.4.8.2~~ SECOND, TAKE ANY ADDITIONAL STEPS AS NECESSARY
20 TO CHECK FOR VOTER ERROR, WHICH SHALL INCLUDE BUT NOT BE LIMITED TO:
21 OVER-VOTES, STRAY MARKS ON THE BALLOT, OR OTHER VOTER INTENT
22 INDICIA; AND

23 ~~11.5.4.8.3~~ THIRD, REVIEW THE SITUATION AND TAKE ACTION AS
24 NECESSARY IN ACCORDANCE WITH THE CANVASS BOARD'S POWERS AS SET
25 FORTH IN 1-10-101 C.R.S.

26 ~~(i)~~11.5.4.9 AT ALL TIMES RELEVANT TO THE POST-ELECTION AUDIT, THE
27 DESIGNATED ELECTION OFFICIAL, THE CANVASS BOARD OR ITS DEPUTIZED CLERKS
28 SHALL TAKE EVERY PRECAUTION NECESSARY TO PROTECT THE CONFIDENTIALITY OF
29 THE BALLOTS CAST BY THE ELECTORS.

30 ~~(j)~~11.5.4.10 UPON COMPLETION OF THE AUDIT, THE DESIGNATED ELECTION
31 OFFICIAL SHALL PROMPTLY REPORT THE RESULTS OF THE AUDIT TO THE SECRETARY
32 OF STATE'S OFFICE. THE REPORT SHALL BE SUBMITTED FOLLOWING THE
33 COMPLETION OF THE AUDIT AND UP TO AND INCLUDING 5:00 PM ON THE LAST DAY
34 OF THE CANVASS. THE REPORT SHALL CONTAIN:

35 ~~(A)~~ THE MAKE, MODEL AND SERIAL NUMBER OF THE VOTING DEVICE
36 THAT WAS AUDITED;

37 ~~(B)~~ THE NUMBER OF BALLOTS ORIGINALLY COUNTED BY THE DEVICE OR
38 THE NUMBER OF BALLOTS AUDITED AS IDENTIFIED IN PARAGRAPH (D) OF
39 THIS SECTION;

40 ~~(C)~~ THE COUNT OF THE SPECIFIC RACE OR RACES AS PROVIDED ON THE
41 SUMMARY REPORT PRINTED AT THE CLOSE OF POLLS OR THE REPORT
42 GENERATED FOR THE AUDIT;

43 ~~(D)~~ THE COUNT OF THE SPECIFIC RACE AS MANUALLY VERIFIED; AND

44 ~~(E)~~ THE SIGNATURE OF THE CANVASS BOARD AND THE DESIGNATED
45 ELECTION OFFICIAL.

- 1 | ~~(11.5.4.11)~~ THE REPORT MAY BE SENT BY ANY OF THE FOLLOWING THREE
2 | METHODS:
3 | E-MAIL: voting.systems@sos.state.co.us; SUBJECT LINE = COUNTY NUMBER,
4 | COUNTY NAME, POST-ELECTION AUDIT; OR
5 | VIA FACSIMILE TO: 303-869-4861 ATTN: SECRETARY OF STATE, VOTING SYSTEMS
6 | SPECIALIST; OR
7 | VIA FIRST CLASS MAIL TO COLORADO DEPARTMENT OF STATE/ ATTN: VOTING
8 | SYSTEMS SPECIALIST/1700 BROADWAY – SUITE 270/DENVER, CO 80290.
- 9 | 11.6 A SET OF SCHEMATICS AND DRAWINGS ON ELECTRONIC VOTE CASTING AND COUNTING
10 | EQUIPMENT PURCHASED OR IN USE BY THE COUNTY CLERK AND RECORDER SHALL BE ON
11 | FILE WITH THE SECRETARY OF STATE.
- 12 | 11.7 ESCROW OF COUNTY ELECTION SETUP
- 13 | 11.7.1 NO LATER THAN 5:00PM ON THE SEVENTH (7TH) DAY PRIOR TO ANY ELECTION, THE
14 | DESIGNATED ELECTION OFFICIAL SHALL DEPOSIT A COPY OF THE ELECTION SETUP
15 | RECORDS TO THE SECRETARY OF STATE’S OFFICE BY MAIL.
- 16 | 11.7.2 JURISDICTIONS WHO HAVE CONTRACTED WITH EITHER A SOFTWARE SERVICE
17 | BUREAU, OR A VENDOR OF ELECTRONIC VOTE COUNTING EQUIPMENT MAY
18 | CHOOSE TO HAVE THE NECESSARY ELECTION SETUP RECORDS DELIVERED TO THE
19 | SECRETARY OF STATE’S OFFICE WITHIN THE SPECIFIED TIME FRAME.
- 20 | 11.7.3 ELECTION SETUP RECORDS SHALL BE CONTAINED WITHIN AN ELECTRONIC MEDIA
21 | FORMAT THAT IS NATIVE TO THE JURISDICTIONS SPECIFIC BALLOT CREATING AND
22 | TABULATION SYSTEM. ACCEPTABLE MEDIA FORMATS RANGE FROM TAPE,
23 | DISKETTE, CARTRIDGE, CD-ROM, DVD-ROM, FLOPPY, EXTERNAL HARD DRIVE,
24 | OR FLASH MEDIA.
- 25 | 11.7.4 ALL COPIES OF ELECTRONIC MEDIA SHALL BE SENT TO:
26 | COLORADO SECRETARY OF STATE
27 | ATTN: VOTING SYSTEMS SPECIALIST
28 | 1700 BROADWAY – SUITE 270
29 | DENVER, CO 80290
- 30 | 11.7.5 JURISDICTIONS WILL INCLUDE A POINT OF CONTACT AND METHOD OF CONTACT
31 | (PHONE, FAX, E-MAIL, ETC.) TO INFORM THE JURISDICTION THAT THE SECRETARY OF
32 | STATE’S OFFICE HAS RECEIVED THE ELECTION SETUP RECORDS.
- 33 | 11.7.6 WITHIN 24 HOURS OF RECEIPT OF THE ELECTION SETUP FILES, THE SECRETARY OF
34 | STATE OR HIS OR HER DESIGNEE WILL CONTACT THE JURISDICTION TO CONFIRM
35 | RECEIPT OF THE ESCROW FILES.
- 36 | 11.7.7 THE SECRETARY OF STATE’S OFFICE WILL STORE THE SETUP FILES IN A SECURED,
37 | FIRE PROOF, LIMITED ACCESS LOCATION OR CONTAINER.
- 38 | 11.7.8 ALL PARTIES SHALL TREAT AS CONFIDENTIAL ALL, ESCROWED MATERIALS AND
39 | ANY OTHER RELATED INFORMATION, WHICH COMES INTO THEIR POSSESSION,
40 | CONTROL OR CUSTODY PURSUANT TO THIS RULE.
- 41 | 11.8 ESCROW OF VOTING SYSTEM PROVIDER VOTING SYSTEM SOFTWARE
- 42 | 11.8.1 VOTING SYSTEM PROVIDERS MUST PLACE A COPY OF THE ELECTION SOFTWARE AND
43 | SUPPORTING DOCUMENTATION BEING CERTIFIED IN ESCROW WITH EITHER THE
44 | SECRETARY OF STATE, OR AN INDEPENDENT ESCROW AGENT APPROVED BY THE
45 | SECRETARY OF STATE. 1-7-511 C.R.S.

- 1 11.8.2 WITHIN 10 DAYS OF THE VOTING SYSTEM PROVIDER RECEIVING NOTIFICATION OF
2 EXAMINATION OF VOTING EQUIPMENT AS PART OF THE CERTIFICATION PROCESS,
3 THE VOTING SYSTEM PROVIDER SHALL ARRANGE FOR THE COMPLETION OF ESCROW
4 REQUIREMENTS AS INDICATED BY THIS RULE.
- 5 11.8.3 VOTING SYSTEM PROVIDER SHALL SIGN A SWORN AFFIDAVIT THAT THE ELECTION
6 SOFTWARE IN ESCROW IS THE SAME AS THE ELECTION SOFTWARE BEING USED IN ITS
7 VOTING SYSTEMS IN THIS STATE. AN ANNUAL UPDATE OF THE AFFIDAVIT WILL BE
8 ON FILE IN A SECURED LOCATION WITH THE SECRETARY OF STATE'S OFFICE.
- 9 11.8.4 A COMPLETE COPY OF THE CERTIFIED ELECTION SOFTWARE INCLUDING ANY AND
10 ALL SUBSYSTEMS OF THE CERTIFIED SOFTWARE SHALL BE MAINTAINED IN ESCROW.
- 11 11.8.5 ANY CHANGES TO CURRENT CONFIGURATIONS OR NEW INSTALLATIONS MUST BE
12 APPROVED THROUGH THE CERTIFICATION PROGRAM OF THE SECRETARY OF STATE.
- 13 11.8.6 IN ADDITION TO THE REQUIREMENTS LISTED BELOW, THE VOTING SYSTEM
14 PROVIDER MUST INCLUDE A COVER/INSTRUCTIONS SHEET FOR ANY ESCROW
15 MATERIAL TO INCLUDE THE VOTING SYSTEM PROVIDER NAME, ADDRESS AND
16 PERTINENT CONTACT INFORMATION, SOFTWARE VERSION, HARDWARE VERSION,
17 FIRMWARE REVISION NUMBER AND OTHER UNIQUELY IDENTIFYING NUMBERS OF
18 THE SOFTWARE BEING SUBMITTED FOR CERTIFICATION.
- 19 11.8.7 ELECTION SOFTWARE SOURCE CODE, MAINTAINED IN ESCROW, SHALL CONTAIN
20 INTERNAL DOCUMENTATION SUCH THAT A PERSON REASONABLY PROFICIENT IN THE
21 USE OF THE PROGRAMMING LANGUAGE CAN EFFICIENTLY USE THE DOCUMENTATION
22 TO UNDERSTAND THE PROGRAM STRUCTURE, CONTROL TECHNIQUES, AND ERROR
23 PROCESSING LOGIC IN ORDER TO MAINTAIN THE SOURCE CODE SHOULD IT BE
24 REMOVED FROM ESCROW FOR ANY REASON.
- 25 11.8.8 SYSTEM DOCUMENTATION SHALL INCLUDE INSTRUCTIONS FOR CONVERTING THE
26 ESCROWED SOURCE CODE INTO OBJECT CODE, ORGANIZED AND CONFIGURED TO
27 PRODUCE AN EXECUTABLE SYSTEM, IF WARRANTED.
- 28 11.8.9 SYSTEM DOCUMENTATION SHALL INCLUDE TECHNICAL ARCHITECTURE DESIGN,
29 ANALYSIS, DETAIL DESIGN, TESTING AND AN INSTALLATION AND CONFIGURATION
30 GUIDE.
- 31 11.8.10 ALL PARTIES SHALL TREAT AS CONFIDENTIAL THE TERMS OF THIS SECTION
32 INCLUDING ALL ESCROW MATERIALS AND ANY OTHER RELATED INFORMATION,
33 WHICH COMES INTO THEIR POSSESSION, CONTROL OR CUSTODY PURSUANT TO THIS
34 SECTION.
- 35 11.8.11 COPIES OF ELECTRONIC MEDIA AND SUPPORTING DOCUMENTATION FOR ESCROW
36 WITHIN THE SECRETARY OF STATE SHALL BE SENT TO:
37 COLORADO SECRETARY OF STATE
38 ATTN: VOTING SYSTEMS SPECIALIST
39 1700 BROADWAY – SUITE 270
40 DENVER, CO 80290
- 41 11.8.12 ANY COST OF USING AN ALTERNATIVE THIRD PARTY ESCROW AGENT SHALL BE
42 BORNE BY THE VOTING SYSTEM PROVIDER.

43 **Rule 12. Rules Concerning Mail Ballot Elections**

44 12.1 Definitions.

- 45 12.1.1 A secrecy sleeve OR SECRECY ENVELOPE shall be sealed or closed on at least two
46 sides, one of which shall be the bottom of the sleeve.

1 12.1.1.1 The secrecy sleeve OR SECRECY ENVELOPE shall be uniform within each
2 type of absentee or mail ballot voting system used in the State of Colorado
3 . Each secrecy sleeve or secrecy envelope used in the State of Colorado in
4 any mail ballot or absentee ballot election shall contain the following
5 required language, approved by the Secretary of State, regarding
6 identification requirements of voters who have registered by mail:

7 (A) "First Time Voters Who Register By Mail

8 If you registered in your county by mail, and DID NOT PROVIDE
9 IDENTIFICATION WITH YOUR REGISTRATION APPLICATION, a **copy** of
10 one of the ~~following~~ forms of identification **listed in Rule 2.3(a)** is
11 required with your mail ballot or your absentee ballot:

- 12 ● ~~A valid Colorado driver's license; or~~
- 13 ● ~~A valid identification card issued by the Department of Revenue IN~~
14 ~~ACCORDANCE WITH THE REQUIREMENTS OF PART 3 OF ARTICLE 2 OF~~
15 ~~TITLE 42, C.R.S.; or~~
- 16 ● ~~A valid U.S. passport; or~~
- 17 ● ~~A valid employee identification card with a photograph of the~~
18 ~~eligible elector issued by any branch, department, agency, or entity~~
19 ~~of the United States government or of this state, or by any county,~~
20 ~~municipality, board, authority, or other political subdivision of this~~
21 ~~state; or~~
- 22 ● ~~A valid pilot's license issued by the federal aviation administration~~
23 ~~or other authorized agency of the United States; or~~
- 24 ● ~~A valid U.S. Military identification card with photograph OF THE~~
25 ~~ELIGIBLE ELECTOR; or~~
- 26 ● ~~A copy of a current utility bill, bank statement, government check,~~
27 ~~paycheck, or other governmental document that shows the name~~
28 ~~and address of the elector (A cable bill, a telephone bill,~~
29 ~~documentation from a public institution of higher education in~~
30 ~~Colorado containing at least the name, date of birth, and LEGAL~~
31 ~~residence address of the student elector, or a paycheck from a~~
32 ~~government institution are sufficient forms of ID); or~~
- 33 ● ~~A valid Medicare or Medicaid card ISSUED BY THE UNITED STATES~~
34 ~~HEALTH CARE FINANCING ADMINISTRATION; or~~
- 35 ● ~~A certified copy of a U.S. birth certificate FOR THE ELECTOR ISSUED~~
36 ~~IN THE UNITED STATES; or~~
- 37 ● ~~Certified documentation of naturalization.~~

38 (B) IF YOU DID NOT SUBMIT PROOF OF IDENTIFICATION
39 WITH YOUR MAIL-IN REGISTRATION FORM, YOU WILL
40 BE REQUIRED TO PROVIDE PROOF OF IDENTIFICATION
41 USING THE TYPES OF IDENTIFICATION DESCRIBED
42 ABOVE WITH YOUR VOTED MAIL OR ABSENTEE
43 BALLOT."

44 (C) Failure to provide ID will result in your ballot being treated as a
45 provisional ballot. Provisional ballots are counted when
46 registration is verified. 1-7.5-107(3.5)(d) C.R.S.

Formatted

- 1 12.1.2 A separate mail ballot plan is not required from a political subdivision if a county
2 clerk and recorder submits a mail ballot plan for a coordinated election which
3 includes the political subdivision.
- 4 12.2 Election Judges.
- 5 12.2.1 The designated election official for the election may appoint an appropriate
6 number of judges to receive the ballots after they are mailed, to handle “walk-in”
7 balloting and absentee ballots at the sites designated for “walk-in” balloting, to
8 check registrations, to inspect, verify, and duplicate ballots when necessary, and
9 to count the ballots and certify results.
- 10 12.3 Notice of elections.
- 11 12.3.1 Call and notice.
- 12 (a) Notice of the election is to be sent to the clerk and recorder of the county
13 in which the election is to be held. The notice is to include the date by
14 which the list of registered electors is to be submitted to the political
15 subdivision.
- 16 (b) For multi-county political subdivisions, the notice sent to each clerk and
17 recorder shall also include the names of all other counties in which the
18 election will be held.
- 19 12.3.2 As soon as possible, but no later than 55 days prior to an election, a written plan
20 must be submitted to the Secretary of State which includes the following:
- 21 a. Date of the election;
- 22 b. Type and name of jurisdiction involved in the election;
- 23 c. Description of the type of election to be conducted;
- 24 d. Citation of the statute or home rule charter provisions authorizing the
25 election;
- 26 e. Estimated number of eligible electors;
- 27 f. Name of the designated election official who will be responsible for all
28 aspects of the election;
- 29 g. Indication of whether the county clerk and recorder will assist in the
30 election for the entity other than by providing a list of registered electors
31 and other information required by statute;
- 32 h. Total number of “places of deposit”. For security reasons, unmonitored
33 freestanding places of deposit located outside will not be allowed.
- 34 i. Written timetable for the conduct of the election in accordance with the
35 statute.
- 36 j. Indication of how postage will be handled for ballot packets returned as
37 undeliverable (e.g. “return postage guaranteed”);
- 38 k. Indication of procedures to be followed to ensure compliance with statutes
39 and rules, including persons responsible for each stage;
- 40 l. Description of procedures to be used to ensure ballot security at all stages
41 of the process;
- 42 m. Description of procedures to be used for signature verification;
- 43 n. Description of procedures to ensure privacy by use of a secrecy sleeve or
44 secrecy envelope so receiving judges cannot tell how the elector voted.
- 45 o. Description of procedures to be used to reconcile ballots issued, ballots
46 received, defective ballots and substitute ballots.

- 1 p. An actual sample of the secrecy sleeve or secrecy envelope to be used in
2 the mail ballot election.
- 3 12.3.3 Written timetable specifications:
- 4 a. The designated election official shall prepare a written timetable for
5 conducting the mail ballot election with specific dates or range of dates
6 when each activity is to be completed.;
- 7 b. The timetable shall include the following dates:
- 8 1. Copy of written plan to governing body;
 - 9 2. Date of approval of election by governing body;
 - 10 3. Date of submission of written plan to Secretary of State's office;
 - 11 4. Anticipated date of approval by Secretary of State;
 - 12 5. Date of publication of notice of election;
 - 13 6. Date of notice of election to the county clerk;
 - 14 7. Date of notice of election to the county assessor, if property
15 owners are eligible to vote in the election;
 - 16 8. Date of close of registration;
 - 17 9. Date by which the county clerk and recorder must submit the list of
18 eligible electors to the political subdivision and, if property owners
19 are eligible to vote in the election, the date by which the county
20 assessor must submit the list of property owners;
 - 21 10. Date ballots will be mailed;
 - 22 11. Date verification and counting of ballots will begin;
 - 23 12. Date of the election.
- 24 12.4 Ballots.
- 25 12.4.1 For elections where multiple ballots will be included in the same packet or will be
26 sent in separate packets, the ballots and return envelopes shall include distinctive
27 markings or colors to identify political subdivisions when the colors or distinctive
28 markings will aid in the distribution and tabulation of the ballots.
- 29 12.4.2 The designated election official for each political subdivision for whom one or
30 more county clerk and recorders are conducting the election shall assure that a
31 complete list of eligible electors in their political subdivision is sent to each
32 appropriate county clerk and recorder, unless otherwise provided in the
33 intergovernmental agreement. The political subdivision shall list each elector
34 only once to assure that each elector receives one and only one ballot unless
35 otherwise authorized.
- 36 12.4.3 For coordinated mail ballot elections, each county clerk and recorder may
37 compare the lists submitted by the various political subdivisions to assure that
38 each elector receives the appropriate ballot or ballots for the election.
- 39 12.4.4 For all coordinated elections where more than one mail ballot is being mailed or
40 polling place elections are being held as well as the mail ballot election, the
41 outgoing envelope as well as the instructions or other notice shall have the
42 following notice: "This may not be your only ballot. Other elections may be held
43 by other political subdivisions by mail or by polling place."
- 44 12.4.5 If the ballot is returned to the election official as undeliverable, the official shall
45 not be required to re-mail the ballot packet.

- 1 12.4.6 The Designated Election Official shall require that the eligible elector submit a
2 copy of his or her identification as defined in Section 1-1-104(19.5), C.R.S., with
3 the elector's ballot in the return envelope if the eligible elector registered to vote
4 by mail pursuant to Part 5, Article 2, Title 1, C.R.S. and did not provide the
5 required ID upon registration.
- 6 12.4.7 The County Clerk and Recorder shall indicate on the list of registered voters
7 requested by the Designated Election Official those registered voters required to be
8 identified in Rule 12.4.6, unless such registered voter either:
9 a. Submitted as part of the registration by mail a copy of the elector's
10 identification as defined in Section 1-1-104(19.5), C.R.S.; or
11 b. Votes pursuant to Section 1-7-111(2), C.R.S.; or
12 c. Is otherwise entitled to vote under any federal law.
- 13 12.4.8 If the elector is required to provide his or her identification, the outside of the
14 return envelope shall be marked to identify such envelope.
- 15 12.4.9 If the marked return envelope does not contain proper identification, the ballot
16 shall be treated as a provisional ballot. The outside of the return envelope shall be
17 marked "provisional". For non-partisan elections, the provisional ballot shall be
18 verified and counted in accordance with Rules 26.9 through 26.20, with the
19 exception of Rule 26.9(d) 20. 1-7.5-107(3.5)(d) C.R.S. and (5)(b).
- 20 12.5 Absentee and Early voting.
- 21 12.5.1 Absentee voting occurs in a mail ballot election when a registered, eligible elector
22 requests that the ballot be mailed to a place other than the address of record.
- 23 12.5.2 AN "IN PERSON" REQUEST FOR AN ABSENTEE BALLOT THAT IS DELIVERED TO THE
24 ELECTOR IN THE CLERK AND RECORDER'S OFFICE MAY BE FILED ANY TIME AFTER
25 JANUARY 1 OF THE YEAR OF THE ELECTION, BUT NO LATER THAN THE CLOSE OF
26 BUSINESS ON THE FRIDAY PRIOR TO THE ELECTION; EXCEPT THAT, IF THE APPLICANT
27 WISHES TO RECEIVE THE ABSENTEE BALLOT BY MAIL, THE APPLICATION SHALL BE
28 FILED NO LATER THAN THE CLOSE OF BUSINESS ON THE ELEVENTH DAY BEFORE THE
29 ELECTION.
- 30 12.5.3 Upon receipt of a request for an absentee ballot, the designated election official
31 shall mail the original ballot or a replacement ballot to that elector.
- 32 12.5.4 A record shall be made on the registration rolls that a request for an absentee
33 ballot was received, a ballot was mailed to the alternate address and the ballot
34 number shall be recorded.
- 35 12.5.5 For mail ballot elections, the notation "Absentee Ballot No. A.V.____" shall not be
36 required on the absentee ballots.
- 37 12.5.6 Establishment of polling place for early voting shall not be required for a mail
38 ballot election, however the location for walk-in balloting shall be maintained.
- 39 12.6 Receipt of Ballots
- 40 12.6.1 One or more judges shall be appointed for the site to which ballots are to be
41 mailed to receive the ballots as mailed.
- 42 12.6.2 Each day when ballots come in, a judge shall count the ballots, batch them and
43 record the number of ballots received.
- 44 12.6.3 The ballots shall be date-stamped when received. If any ballot is received after
45 the time set for the closing of the elections, the ballot shall be date-stamped but
46 the ballot shall not be counted.

- 1 12.6.4 Records shall also be kept of the number of ballot packets returned as
2 undeliverable.
- 3 12.6.5 Ballot packets shall then be placed in a safe, secure place until the counting of the
4 ballots.
- 5 12.7 IF A VOTER HAS BEEN DIRECTED TO RETURN A DOCUMENT WITH HIS/HER VOTED BALLOT,
6 THE ELECTION JUDGE SHALL OPEN THE RETURNED ENVELOPE TO RETRIEVE THE REQUIRED
7 FORM. IF THE REQUIRED FORM CANNOT BE FOUND IN THE RETURN ENVELOPE, THE
8 ELECTION JUDGE SHALL OPEN THE SECRECY ENVELOPE/SLEEVE TO FIND THE REQUIRED
9 FORM OR DOCUMENT IN AN EFFORT NOT TO DISENFRANCHISE THE VOTER.
- 10 12.8 FOR ANY NON-MATCHING OR MISSING SIGNATURE ON A MAIL BALLOT RETURN ENVELOPE,
11 RULE 29 CONCERNING PROCEDURES FOR THE VERIFICATION OF SIGNATURES SHALL BE
12 FOLLOWED.
- 13 12.9 Ballots ~~D~~elivered in ~~P~~erson.
- 14 12.9.1 If political subdivision desires to establish a site for walk-in voting outside of the
15 county, municipality or district, permission must be obtained from the Secretary
16 of State.
- 17 12.9.2 Any eligible elector may deliver in person to the designated or coordinated
18 election official's office no more than 5 voted mail ballots from members of his or
19 her household.
- 20 12.10 Replacement Ballots for Purpose of Mail Ballot Elections.
- 21 12.10.1 Requests for replacement ballots may be made in writing, by mail, by fax,
22 or by telephone.
- 23 12.10.2 An elector requesting a replacement ballot shall complete a sworn
24 statement, as required by section 1-7.5-107(3) (d) (I) C.R.S., on a form provided
25 by the designated election official.
- 26 12.10.3 The AFFIDAVIT shall include space in which the elector shall specify the
27 reason for requesting a replacement ballot. The AFFIDAVIT shall also contain a
28 statement in bold that the original ballot may not be cast and that, if both the
29 original and the replacement ballot are cast, neither ballot will be counted. If the
30 elector requested that the replacement ballot be mailed, the AFFIDAVIT may be
31 included in the ballot packet mailed to the eligible elector, AND MUST BE RECEIVED
32 ON OR BEFORE ELECTION DAY BY THE ELECTION OFFICIAL.
- 33 12.10.4 The election judge issuing a replacement ballot shall indicate on the
34 outside of the return-verification envelope whether a sworn statement must be
35 returned with the voted ballot. No replacement ballot shall be counted until it has
36 been determined that an AFFIDAVIT has been completed by the voter AND HAS
37 BEEN RECEIVED ON OR BEFORE ELECTION DAY BY THE ELECTION OFFICIAL.
- 38 12.11 Verification of Replacement Ballots
- 39 12.11.1 Upon issuance of A replacement ballot, **THE FIRST VOTED BALLOT**
40 **RETURNED BY THE ELECTOR SHALL BE CONSIDERED THE ELECTOR'S OFFICIAL**
41 **BALLOT, PURSUANT TO 1-8-111(3) C.R.S.**
- 42 12.11.2 If a return verification envelope is submitted which contains a replacement
43 ballot it shall be set aside until 7:00 p.m. on election day. If it can be determined
44 that the replacement ballot is the only ballot issued to the elector or that all prior
45 ballots issued to the elector have been voided, it may be processed in the same
46 manner as the original ballot.

- 1 12.11.3 The information on the return verification envelope may be checked prior
2 to 7:00 p.m. on election day, but the ballot may not be removed until the polls
3 close.
- 4 12.11.4 When all voted ballots have been received and the polls closed, the
5 replacement ballots shall be checked to ensure that the elector only voted with the
6 replacement ballot. If it appears that the elector only voted the replacement ballot
7 and if all the information is complete on the return verification envelope, the
8 ballot may be removed and counted as the other ballots.
- 9 12.12 Judges Duties.
- 10 12.12.1 The judges shall record the results of the election on the judges' certificate
11 and statement.
- 12 12.12.2 The judges shall deliver the results of the election to the designated
13 election official along with all election materials.
- 14 12.12.3 The judges shall deliver all election materials bound separately as follows:
15 a. Ballots which were counted;
16 b. Ballots which were defective, as defined in 1-7-309(4);
17 c. Ballots/verification envelopes which may be challenged;
18 d. Verification envelopes with ballots removed;
19 e. Defective verification envelopes with ballots inside;
20 f. Ballot packets which were returned as undeliverable.
- 21 12.13 Canvass of votes/certificates of election.
- 22 12.13.1 Elections can be challenged as provided in the enabling statute of the
23 entity calling the election.
- 24 12.13.2 A failure of an elector to receive a ballot will not by itself be sufficient
25 grounds for the challenge of an election, so long as the designated election official
26 acted in substantial compliance with Title 1, Article 7.5, C.R.S. or the rules
27 promulgated thereunder by the Secretary of State.
- 28 **Rule 13. Rules Concerning Absentee Voting**
- 29 13.1 All election materials prepared by the designated election official, including the Article
30 X, Section 20 notice, may be included in the absentee ballot mailing.
- 31 13.2 The county clerk and recorder shall keep a list, to the extent possible, of THE NAMES AND
32 MAILING ADDRESSES OF all individuals who deliver more than five voted absentee ballots
33 to the designated or coordinated election official's office or the designated drop site for
34 absentee ballots.
- 35 13.3 The county clerk and recorder shall notify each individual on the list REQUIRED BY 13.2
36 by letter that they have violated 1-8-113 C.R.S. by delivering more than five absentee
37 ballots to the designated election official.
- 38 13.4 The Designated Election Official shall require that the eligible elector submit a copy of his
39 or her identification as defined in Section 1-1-104(19.5), C.R.S., with the elector's ballot
40 in the return envelope if the eligible elector registered to vote by mail pursuant to Part 5,
41 Article 2, Title 1, C.R.S. and failed to include the copy with the original registration OR
42 FAILED TO SUPPLY A DRIVER'S LICENSE NUMBER, COLORADO DEPARTMENT OF REVENUE
43 ID NUMBER OR AT LEAST THE LAST FOUR DIGITS OF A SOCIAL SECURITY NUMBER THAT WAS
44 SUBSEQUENTLY VERIFIED PER RULE 30.5.

- 1 13.5 The County Clerk and Recorder shall indicate on the list of registered voters requested by
2 the Designated Election Official those registered voters required to be identified in Rule
3 13.4.
- 4 13.6 If the elector is required to provide his or her identification, the outside of the return
5 envelope shall be marked to identify such envelope. A COUNTY MAY USE ADDITIONAL
6 METHODS TO COMMUNICATE THE REQUIREMENT TO PROVIDE IDENTIFICATION. The elector
7 shall also be provided with specific instructions on the requirement to provide such
8 identification.
- 9 13.7 If the marked return envelope does not contain proper identification, the ballot shall be
10 treated as a provisional ballot. The outside of the return envelope shall be marked
11 "provisional". The provisional ballot shall be verified and counted in accordance with 1-
12 8.5-105(5) C.R.S.
- 13 13.8 IF A VOTER HAS BEEN DIRECTED TO RETURN A DOCUMENT WITH HIS OR HER VOTED BALLOT,
14 THE ELECTION JUDGE SHALL OPEN THE RETURNED ENVELOPE TO RETRIEVE THE REQUIRED
15 FORM. IF THE REQUIRED FORM CANNOT BE FOUND IN THE RETURN ENVELOPE, THE
16 ELECTION JUDGE SHALL OPEN THE SECRECY ENVELOPE/SLEEVE TO FIND THE REQUIRED
17 FORM OR DOCUMENT IN AN EFFORT TO NOT DISENFRANCHISE THE VOTER.
- 18 13.9 FOR ANY NON-MATCHING OR MISSING SIGNATURES ON AN ABSENTEE BALLOT RETURN
19 ENVELOPE, RULE 29 CONCERNING PROCEDURES FOR THE VERIFICATION OF SIGNATURES
20 SHALL BE FOLLOWED.
- 21 13.10 The designated election official's duties under 1-8-112 C.R.S. are triggered if the U.S.
22 mail is delivered collectively to the residential facility. If the U.S. mail is delivered to
23 individuals or individual mailboxes, the requirements of 1-8-112 C.R.S. shall not be
24 applicable.
- 25 13.11 Voters who appear in person at their correct polling place, but who requested absentee
26 ballots, will nevertheless be permitted to cast provisional ballots upon their declaration
27 that they have not and will not cast any vote in the election other than by that provisional
28 ballot. The provisional ballot is then to be counted, once election officials determine that
29 the voter did not in fact cast the absentee ballot.
- 30 **Rule 14. Rules Concerning Recount**
- 31 14.1 Each designated election official who conducts a recount shall follow the specific
32 procedures outlined by the Secretary of State for the equipment used for the election.
- 33 14.2 The Secretary of State shall prepare a letter **THAT** specifies the procedures to be used for
34 the recount which shall be sent to the designated election official upon receipt of the
35 notice of a recount.
- 36 14.3 The purpose of a recount is to review the ballots to assure they were counted properly.
37 Unless directed otherwise by the Secretary of State, all procedures of election night shall
38 be followed as closely as possible during the recount, including an examination of the
39 ballots.
- 40 14.4 General Provisions
- 41 14.4.1 The Secretary of State may have an official observer at every recount location.
- 42 14.4.2 Any candidate who is subject to the recount may be present and observe the
43 recount at any recount location or designate one Watcher to observe the recount at
44 any recount location. Watchers must provide the election official with a
45 certificate signed by the candidate, except that an officer of the county party may

- 1 be accepted as a candidate's watcher without a certificate if no other person is
2 designated by the candidate for that location.
- 3 14.4.3 Each candidate, his or her watcher, members of the media, and official observers
4 as defined in Rule 8.1.1, may be present in the room when a recount is conducted.
5 During the recount the candidate, watcher, members of the media, and official
6 observers may not interfere with the recount process.
- 7 14.4.4 The recount board, as defined by the Secretary of State, candidates, watchers,
8 members of the media, and official observers will take an oath.
- 9 14.4.5 Candidates, watchers, members of the media, and official observers who enter the
10 recount room after the recount begins must stay until the recount is complete.
11 Anyone who must leave the recount room will not be allowed to re-enter the
12 recount room without the specific consent or authorization of the designated
13 election official.
- 14 14.4.6 All votes for all candidates in any race subject to a recount shall be counted.
- 15 14.5 Counting of Paper Ballots - Recount
- 16 14.5.1 Totals of recounted ballots shall be processed, counted, and reported in summary
17 form as follows:
- 18 a. Sum total of votes cast for each candidate, under-votes, and over-votes for
19 all precincts;
- 20 b. Sum total of votes cast for each candidate, under-votes, and over-votes for
21 all absentee ballots (a combined total, not totaled by individual precincts
22 or locations, unless the voting system so allows.);
- 23 c. Sum total of votes cast for each candidate, under-votes, and over-votes for
24 all early voting precincts (a combined total, not totaled by individual
25 precinct or locations, unless the voting system so allows.);
- 26 d. Determine grand total of ballots cast by early voting, absentee voting, and
27 precinct voting.
- 28 14.5.2 If absentee ballots were originally counted with early voting ballots, then the
29 recount will be of a combined total of early and absentee ballots.
- 30 14.5.3 Ballot boxes or containers shall be opened one at a time.
- 31 14.5.4 Ballots shall be counted into groups of 25 to ensure that the number of ballots
32 recounted matches the number originally counted.
- 33 14.5.5 Votes shall be counted by individual hash marks in 25-count sections by two
34 different judges.
- 35 14.6 Counting of punch-card ballots-Recount
- 36 14.6.1 Prior to the recount, the canvass board shall choose a precinct at random to be
37 utilized as a test deck for purposes of section 1-10.5-102 C.R.S. The purpose of a
38 test deck is to assure the tabulation machines are counting properly. The precinct
39 chosen shall contain at least 50 ballots. A hand tally shall be conducted of the
40 selected precinct or of a minimum of fifty ballots contained within the selected
41 precinct. The ballots from the selected precinct test deck shall be processed
42 through all tabulation machines that will be utilized for the recount. The totals of
43 the recounted contest obtained from the test precinct shall be compared to the
44 hand-tallied total.
- 45 14.6.2 If the test deck precinct totals differ from the hand count totals, all ballots
46 containing the recounted contest shall be tallied by hand following procedures for

- 1 paper ballot recounts. If the test deck precinct totals are exactly the same, the
2 recount tabulation shall be conducted by machines.
- 3 14.6.3 A clear audit trail shall be maintained throughout the recount including, but not
4 limited to, a log of seal numbers on transfer cases or ballot boxes as defined in
5 section 1-7-505, C.R.S., and the corresponding numbered seal used as a
6 replacement, upon completing the recount of ballots within that transfer case.
- 7 14.6.4 The number of ballots counted by precinct according to the election night report
8 shall be available during the recount for comparison purposes.
- 9 14.6.5 Totals of recounted ballots shall be processed, counted, and reported in summary
10 form as follows:
- 11 a. Sum total of votes cast for each candidate, under-votes, and over-votes for
12 all precincts;
- 13 b. Sum total of votes cast for each candidate, under-votes, and over-votes for
14 all absentee ballots (a combined total, not totaled by individual precincts
15 or locations, unless the voting system allows);
- 16 c. Sum total of votes cast for each candidate, under-votes, and over-votes for
17 all early voting precincts (a combined total, not totaled by individual
18 precincts or locations, unless the voting system so allows);
- 19 d. Determine the grand total of ballots cast in early, absentee, and precinct
20 voting.
- 21 14.6.6 If absentee ballots were originally counted with early voting ballots, then the
22 recount will be of a combined total of early and absentee ballots.
- 23 14.6.7 Ballots shall be reviewed for voter intent.
- 24 14.6.8 Utilizing a cleared reader, all precinct ballots shall be counted within all precincts.
25 Precincts shall be counted in numeric order. After the individual precinct is
26 counted, the ballots shall be returned to the ballot container and sealed.
- 27 14.6.9 Utilizing a cleared reader, all early voting ballots shall be counted. After an
28 individual ballot container is counted, the ballots shall be returned to the ballot
29 container and sealed.
- 30 14.6.10 Utilizing a cleared reader, all absentee voting ballots shall be counted.
31 After an individual ballot container is counted, the ballots shall be returned to the
32 ballot container and sealed.
- 33 14.7 Counting of Optical Scan Ballots - Recount
- 34 14.7.1 All optical scan tabulation machines to be used in the recount must be tested prior
35 to the recount, utilizing the procedures set forth in this section. Prior to the
36 recount, the canvass board shall choose at random **AND TEST VOTING DEVICES**
37 **AND PRECINCT(S)** to be utilized as a test deck for purposes of section 1-10.5-102.
38 The purpose of a test deck is to assure the tabulation machines are counting
39 properly. The precinct chosen shall contain at least 50 ballots. A hand tally shall
40 be conducted of the selected precinct or of a minimum of fifty ballots contained
41 within the selected precinct. A blank prom cartridge, rom cartridge, or memory
42 card shall be utilized for the test deck. The ballots from the selected precinct test
43 deck shall be processed through all scan tabulation machines that will be utilized
44 for the recount. The totals of the recounted contest obtained from the test precinct
45 shall be compared to the hand-tallied total.

- 1 14.7.2 If the test deck precinct totals differ from the hand count totals, **AND THE**
2 **DISCREPANCY CANNOT BE ACCOUNTED FOR BY VOTER ERROR**, all ballots
3 containing the recounted contest shall be tallied by hand following procedures for
4 paper ballot recounts. If the test deck precinct totals are exactly the same, the
5 recount tabulation shall be conducted by machines.
- 6 14.7.3 A clear audit trail shall be maintained throughout the recount including, but not
7 limited to, a log of seal numbers on transfer cases or ballot boxes as defined 1-7-
8 505, C.R.S., and the corresponding numbered seal used as a replacement, upon
9 completing the recount of ballots within that transfer case.
- 10 14.7.4 The number of ballots counted by a precinct according to the election night report
11 shall be available during the recount for comparison purposes.
- 12 14.7.5 Totals of recounted ballots shall be processed, counted, and reported in summary
13 form as follows:
- 14 a. Sum total of votes cast for each candidate, ballot issue or ballot question
15 subject to the recount, under-votes, and over-votes for all precincts;
- 16 b. Sum total of votes cast for each candidate, ballot issue or ballot question
17 subject to the recount, under-votes and over-votes for all absentee ballots
18 (a combined total, not totaled by individual precincts or location, unless
19 your system allows);
- 20 c. Sum total of votes cast for each candidate, ballot issue or ballot question,
21 subject to the recount, under-votes, and over-votes for all early voting
22 locations (a combined total, not totaled by individual precinct or locations,
23 unless the voting system so allows);
- 24 d. Determine the grand total of ballots cast in early, absentee, and precinct
25 voting.
- 26 14.7.6 If absentee ballots were originally counted with early voting ballots, then the
27 recount will be of a combined total of early and absentee ballots.
- 28 14.7.7 Ballots shall be reviewed for voter intent.
- 29 14.7.8 Utilizing one or more blank prom cartridge, rom cartridges, or memory card, all
30 precinct ballots shall be counted within all precincts. After the individual precinct
31 is counted, the ballots shall be returned to the ballot container and sealed.
- 32 14.7.9 Utilizing one or more blank prom cartridge, rom cartridges, or memory card, all
33 early voting ballots shall be counted. After an individual ballot container is
34 counted, the ballots shall be returned to the ballot container and sealed.
- 35 14.7.10 Utilizing one or more blank prom cartridges, rom cartridges, or memory
36 card, all absentee voting ballots shall be counted. After an individual ballot
37 container is counted, the ballots shall be returned to the ballot container and
38 sealed.
- 39 14.8 Counting of Ballots Using the “Ballot Now” Voting System
- 40 14.8.1 In the case of a recount, the designated election official shall identify all precincts
41 with the contest(s) designated for a recount using the following procedures:
- 42 a. Using the Ballot Now Scanned Ballots by Precinct report from the original
43 election database, locate the batches containing any ballot type (Election,
44 Absentee, and Provisional) for the recount.
- 45 b. Remove ballots from each batch and label them as “Recount”.

1 14.8.2 Required scanner testing shall be performed using a test deck from a randomly
2 chosen precinct with at least 50 ballots as prescribed by statute, following
3 testing procedures outlined in the State of Colorado Procedures for the use
4 of the Ballot Now Voting System. A Recount Test spreadsheet shall be
5 created based on the chosen precinct in the same fashion as the ballot
6 options test spreadsheet. **A. IF THE TEST DECK PRECINCT**
7 **TOTALS DIFFER FROM THE HAND COUNT TOTALS, AND THE DISCREPANCY**
8 **CANNOT BE ACCOUNTED FOR BY VOTER ERROR, ALL BALLOTS**
9 **CONTAINING THE RECOUNTED CONTEST SHALL BE TALLIED BY HAND,**
10 **FOLLOWING PROCEDURES FOR PAPER BALLOT RECOUNTS. IF THE TEST**
11 **DECK PRECINCT TOTALS ARE EXACTLY THE SAME, THE RECOUNT**
12 **TABULATION SHALL BE CONDUCTED BY ELECTRONIC VOTE TABULATING**
13 **EQUIPMENT.**

14 14.8.3 Ballots for the recount shall be processed following the State of Colorado
15 Procedures for the use of the Ballot Now Voting System in conjunction with the
16 following procedures:
17 a. Open Ballot Now with an unused MBB (Mobile Ballot Box) from the
18 election and create a Ballot Now recount database;
19 b. Scan and resolve all recount ballots following original election procedures,
20 including the examination of ballots (Rule 14.3; 1-8-10.5-102 C.R.S) Use
21 the Audit Trail Report and original Scan Batch Reports with notes to
22 ensure resolution action follows original resolution.
23 c. Save all recount CVRs (Cast Vote Records) to the MBB (Mobile Ballot
24 Box) after verifying that the number of ballots processed matches the
25 number of ballots cast in the recount contest(s).
26 d. Open a new recount election in “Tally” and process the recount MBB
27 following the tabulation procedures above.
28 e. Compare recount results to original results and document any differences.
29 f. Backup the test database and the official recount database following the
30 “Archive” procedures.

31 **Rule 15. Rules Concerning Preparation and Filing of Statewide Initiative Petitions**

32 15.1 Each petition section shall have on it a consecutive four-digit number. The number may
33 be printed by a printer, hand-stamped with a manual stamp, or handwritten.

34 15.2 The lines on the petition section shall be consecutively numbered.

35 15.2.1 The block of information which consists of the printed last name, first name,
36 middle initial, county, signing date, street address, city and signature is considered
37 a line.

38 15.3 No petition shall be accepted which lists proponents other than the two identified as
39 petition representatives pursuant to 1-40-104 C.R.S.

40 15.4 Proponents may begin circulating a petition for signatures at any time after the final
41 decision of the title board, including disposition of any motion for rehearing or the
42 expiration of the time for filing a motion for rehearing, and after the Secretary of State
43 has approved the format of the petition as provided in section 1-40-113 (1) C.R.S.,
44 whether or not an appeal is filed with the Supreme Court pursuant to section 1-40-107
45 (2). The six-month period specified in section 1-40-108 (1) shall begin on the date that
46 the first signature is affixed to the petition or, in the case of an appeal to the Supreme

- 1 Court, on the date that the decision of the Supreme Court becomes final, whichever date
2 occurs first. Signatures shall be counted only if affixed to the petition during the period
3 provided in this rule.
- 4 15.5 Only one filing of a petition or an addendum is allowed. After a petition or an addendum
5 is filed, the petition or the addendum may not be supplemented with additional
6 signatures. If additional signatures are submitted after the original filing, such signatures
7 shall not be counted, even if such signatures are submitted within the time permitted by
8 law for the filing of the original petition or addendum.
- 9 **Rule 16. Rules Concerning Verification by Random Sample of Statewide Initiative**
10 **Petitions**
- 11 16.1 Preliminary count and generation of random numbers.
- 12 16.1.1 When the petitions are received, each section shall be consecutively numbered.
- 13 16.1.2 Each line with writing shall be counted on each petition and shall be considered
14 an entry. The number of entries for each page of the section shall be written on
15 the page, and the total entries for the section shall be written on the face of the
16 petition section.
- 17 (a) A line which has no writing or marks on it shall not be considered an
18 entry.
- 19 (b) A line which has writing on it but is completely crossed out shall not be
20 considered an entry.
- 21 (c) A line which has writing on it but is incomplete or on its face contains an
22 invalid signature or which is partially crossed out shall be considered an
23 entry to be included in this count.
- 24 16.1.3 After the entries have been counted for each petition section, a data entry clerk
25 shall enter the following data into the computer; the petition identification
26 number, the petition section number, the page number and the number of entries
27 on the page.
- 28 16.1.4 The computer shall then create a record for each entry which record shall contain
29 the petition identification number, petition section number, page number and the
30 entry number. The total number of entries submitted for the petition shall be
31 tallied.
- 32 16.1.5 If the number of entries is less than the total number of signatures required to
33 certify the measure to the ballot, a statement of insufficiency shall be issued.
- 34 16.1.6 A series of random numbers shall be generated by the computer which is the
35 greater of four thousand signatures or five percent of the total number of entries.
- 36 16.2 Verification of selected entries.
- 37 16.2.1 The random numbers selected shall be matched with the appropriate petition
38 section, page number and entry number.
- 39 16.2.2 Each entry generated shall be checked for validity in accordance with Rules
40 22.3.3 and 22.3.4:
- 41 a. Evidence of disassembly of the petition;
- 42 b. The circulator's affidavit does not meet the requirements of statute or rule;
- 43 c. The individual entry does not meet the requirements of statute or rule.
- 44 16.2.3 Each reason for rejection of an entry shall be recorded by separate code and a
45 master record of the rejected entries shall be maintained. A master record shall
46 also be maintained of each entry that is accepted.

- 1 16.3 Each section shall be checked for evidence of disassembly. If it appears that the section
2 was disassembled, the entry shall be rejected.
- 3 16.4 Checking the circulator's affidavit.
- 4 16.4.1 The circulator's affidavit shall be checked for each entry. If the affidavit is not
5 attached and completed, the entry shall be rejected.
- 6 16.4.2 The notary clause at the end of the affidavit shall be checked for each entry. If
7 any information is missing or if the date on the notary clause is not the same date
8 as the circulator signed the affidavit, the entry shall be rejected.
- 9 16.4.3 The name of each circulator shall be checked to assure that the circulator was a
10 registered elector at the time that the signatures were gathered. If the circulator
11 was not a registered elector, the entry shall be rejected.
- 12 16.4.4 If the information on the current voter registration file does not match the
13 information on the entry, the circulator's voter registration history shall be
14 checked to determine if the information on the affidavit matches the voter
15 registration file at the time the entry was signed.
- 16 16.5 Checking individual signatures.
- 17 16.5.1 Each individual entry shall be checked against the master voter registration files.
- 18 16.5.2 If the information on the current voter registration file does not match the
19 information on the entry, the elector's voter registration history shall be checked
20 to determine if the information on the entry matches the voter registration file at
21 the time the entry was signed.
- 22 16.5.3 Name of registered elector: to be accepted, the name on the entry must be found
23 in form similar to that found on the voter registration record. Signatures that are
24 common variants of the name found on the voter record shall be counted. If the
25 signer of the petition is not found on the voter registration file, the entry shall be
26 rejected.
- 27 16.5.4 Middle initial and additional terms.
- 28 (a) If the middle initial or middle name is not part of either the signature line
29 or the voter record but is included on the other document, if the first and
30 last name are the same on both documents, the entry shall be accepted.
- 31 (b) If the middle initial or middle name on the signature line is different than
32 the middle initial or middle name on the voter record, the entry shall be
33 rejected.
- 34 (c) If an indicator such as Jr., Sr. or II is present or omitted from the petition
35 or the voter record, the entry shall be accepted. If two persons with the
36 same name reside at the same address as found on the master voter list, the
37 entry shall be rejected, unless the identity of the signer can be conclusively
38 determined.
- 39 16.5.5 Address of registered elector.
- 40 (a) If the address written on the line does not match the address on the voter
41 record or on the voter history for the date when the signature was taken,
42 the entry shall be rejected.
- 43 (b) If the address on the petition either includes or omits a letter or number
44 identifying an apartment or the directional location of a street, such as "E"
45 for east, "SW" for southwest, etc., the entry shall be accepted.

- 1 (c) If the signer has a post office box for the address, the entry shall be
2 rejected.
- 3 16.5.6 Incomplete information: if the line on the petition is incomplete, with at least one
4 piece of information omitted, the entry shall be rejected.
- 5 16.5.7 Date of signing.
- 6 (a) If a signature is placed on the petition prior to the final approval of the
7 petition format by the designated election official, the entry shall be
8 rejected.
- 9 (b) If the SIGNATURE is placed on the petition after the date on the circulator's
10 affidavit, the entry shall be rejected.
- 11 16.5.8 Assistance to signer: if assistance appears to have been given to the signer and no
12 statement of assistance accompanies the signature or mark explaining the variance
13 in the script, the entry shall be rejected.
- 14 16.5.9 Illegible signature: if the signature and printed name are illegible so that the voter
15 record cannot be verified, the entry shall be rejected.
- 16 16.5.10 Duplicate signature: if the elector had previously signed the same petition, the
17 first valid entry shall be counted and all other entries shall be rejected.
- 18 16.6 Computation of total accepted signatures.
- 19 16.6.1 A tally shall be made of the number of accepted signatures and the number of
20 rejected signatures.
- 21 16.6.2 The Secretary of State shall determine the range of signatures by multiplying the
22 constitutionally required number of signatures by 0.90 to compute 90% of the
23 required signatures and by 1.10 to compute 110% of the required signatures. This
24 number shall be calculated once every four years after the general election at
25 which the Secretary of State was elected.
- 26 16.6.3 After completing a petition, the number of signatures checked shall then be
27 divided into the number of accepted signatures. This number will be the
28 percentage of accepted signatures which were submitted.
- 29 16.6.4 The percentage calculated in Rule 16.6.3 shall then be multiplied by the total
30 number of entries which were previously tallied. This number will be the number
31 of presumed valid signatures which were submitted.
- 32 16.6.5 If the number generated is 90% or less of the constitutionally required number of
33 signatures as calculated in Rule 16.6.2, then the Secretary of State shall issue a
34 statement of insufficiency. If the number generated is 110% or more of the
35 constitutionally required number, then the Secretary of State shall issue a
36 statement of sufficiency.
- 37 16.6.6 If the number generated is more than 90% but less than 110% of the required
38 number, the Secretary of State shall order that each signature on the petition be
39 verified to determine whether the issue or question should be certified to the
40 ballot.
- 41 **Rule 17. Rules Concerning Verification of All Signatures**
- 42 17.1 Rules concerning verification of statewide initiative petitions when all signatures are
43 counted.
- 44 17.2 The process for checking all signatures shall be the same as for random sample of
45 checking, with the following exceptions.

- 1 17.3 Each petition section shall be checked for evidence of disassembly. If it appears that the
2 section was disassembled, all signatures on the petition section shall be rejected.
- 3 17.4 Checking the circulator's affidavit.
- 4 17.4.1 Each petition section shall be checked for the completed circulator's affidavit. If
5 the affidavit is not attached and completed, all signatures on the section of the
6 petition shall be rejected.
- 7 17.4.2 Each petition section shall be checked to assure that the notary clause at the end
8 of the affidavit is completed. If any information is missing or if the date in the
9 notary clause is not the same date as the circulator signed the affidavit, all
10 signatures on the section of the petition shall be rejected.
- 11 17.4.3 Except in the case of initiative petitions, the name of each circulator shall be
12 checked to assure that the circulator was a registered elector at the time that the
13 signatures were gathered. Any signatures gathered while the circulator was not a
14 registered elector shall be rejected.
- 15 17.5 Each individual entry shall be verified using the same criteria as found in Rule 16.5.
- 16 17.6 Final Tally: After all of the sections have been checked, a final tally of all valid
17 signatures shall be prepared and the statement of sufficiency issued.
- 18 **Rule 18. Rules Concerning Statement of Sufficiency FOR STATEWIDE PETITIONS**
- 19 18.1 Within the time required by statute, the Secretary of State shall issue a statement of
20 sufficiency or insufficiency.
- 21 18.2 The statement shall contain the name of the petition, the proponents, and the date the
22 petition was submitted for verification.
- 23 18.3 The statement shall indicate the total number of entries, the total number of entries
24 accepted, and the total number of entries rejected.
- 25 18.4 The statement shall indicate whether an insufficient number of entries was submitted, the
26 number of presumed valid signatures if a random sample was conducted, and the number
27 of valid signatures counted if every entry was counted.
- 28 18.5 Records: The designated election official shall assure that a record of all signatures
29 rejected and the reasons for each rejection be maintained as public records.
- 30 **Rule 19. Rules Concerning Cure FOR STATEWIDE PETITIONS**
- 31 19.1 Cure of petitions deemed insufficient.
- 32 19.2 If the proponents submit additional signatures within the permitted time, all signatures
33 submitted in the addendum shall be checked using the process delineated in Rule 16 and
34 Rule 17.
- 35 19.3 If the number of valid signatures in the addendum when added to the number of valid
36 signatures given in the statement of insufficiency equals 110% or more of the required
37 signatures, a statement of sufficiency shall be issued.
- 38 19.4 If the number of valid signatures in the addendum when added to the number of valid
39 signatures given in the statement of insufficiency equals more than 90% but less than
40 110% of the required signatures and the initial check was by random sample, all of the
41 previously submitted entries shall be checked. The total of valid signatures in the
42 original petition shall then be added to the number of valid signatures submitted in the
43 addendum.
- 44 19.5 If the initial check was of every entry, then the total of valid signatures shall be added to
45 the number of valid signatures submitted in the addendum.

- 1 19.6 The designated election official shall then issue a new statement of insufficiency or
2 sufficiency which reports the total number of valid signatures submitted.
- 3 **Rule 20. Rules Concerning Protests**
- 4 20.1 Protests of statewide initiative petitions.
- 5 20.2 Protest of random sampling process.
- 6 20.2.1 Proponents and opponents may protest the process by which the numbers used in
7 the calculations were generated.
- 8 20.2.2 Proponents and opponents may protest that the process used for determining
9 entries and generating the random sample did not meet the requirements
10 established by statute or rule.
- 11 20.2.3 Proponents and opponents may protest that entries were improperly accepted or
12 rejected in that the requirements established by statute or rule were improperly
13 applied.
- 14 (a) If the protest alleges that individual entries were improperly accepted or
15 rejected, each individual entry must be listed and the reason for challenge
16 must be given.
- 17 (b) The reason for challenge must state which of the requirements established
18 by statute or rule were improperly applied.
- 19 20.2.4 Individual entries which were not checked by the Secretary of State may not be
20 challenged as sufficient or insufficient.
- 21 20.3 Protest of petitions when all signatures are checked.
- 22 20.3.1 Proponents and opponents protesting the checking of petitions when each
23 signature was checked must list each individual entry being protested and the
24 reason for challenge.
- 25 20.3.2 The reason for challenge must state which of the requirements established by
26 statute or rule were improperly applied.
- 27 20.3.3 The protest shall be deemed insufficient for each entry or class of entries
28 challenged where the individual entry is not listed or the reason for the challenge
29 is not given.
- 30 **Rule 21. Rules Concerning Ballot Issue Elections**
- 31 21.1 Placing measures on the ballot for coordinated odd-year elections.
- 32 21.1.1 For statewide elections, the Secretary of State shall be responsible for determining
33 whether the proposed initiative concerns state matters arising under Section 20 of
34 Article X of the State Constitution and as thus is eligible to appear on the ballot at
35 an odd-year election.
- 36 21.1.2 For elections concerning counties or other political subdivisions, if the election is
37 held as a coordinated election, each political subdivision shall determine whether
38 the proposed initiative or referred measure is a local government matter arising
39 under Section 20 of Article X of the State Constitution.
- 40 **21.2 Written comments concerning ballot issues submitted to the designated election
41 official for the political subdivision shall not be withdrawn after the end of the
42 business day on the last Friday immediately preceding the forty-fifth day before the
43 election. Rule 22. Rules Concerning Checking Candidate and Issue Petitions.**
- 44 22.1 Applicability. This rule shall apply to candidate and issue petitions authorized by law
45 except as to municipal candidate or issue petitions.
- 46 22.2 Procedures for preparing petitions for circulation.

- 1 22.2.1 Each petition section shall have on it a consecutive four-digit number. The
2 number may be printed by a printer, hand stamped with a manual stamp or
3 handwritten. A petition section shall be either an individual sheet for signatures
4 or multiple sheets which are stapled together.
- 5 22.2.2 The lines on the petition section shall be consecutively numbered.
- 6 (a) The block of information which consists of the printed last name, first
7 name, middle initial, county, signing date, resident street address, city and
8 signature is considered a line.
- 9 22.2.3 No petition shall be accepted which lists proponents other than those authorized
10 by statute.
- 11 22.3 Procedures concerning count of signatures and verification of petition.
- 12 22.3.1 When the petitions are received, each section shall be date-stamped and
13 consecutively numbered.
- 14 22.3.2 Each line with writing shall be counted on each petition and shall be considered
15 an entry. The number of entries for each page of the section shall be written on
16 the page and the total entries for the section shall be written on the face of the
17 petition section.
- 18 (a) A line that has no writing or marks on it shall not be considered an entry.
- 19 (b) A line that has writing on it but is completely crossed out shall not be
20 considered an entry.
- 21 (c) A line which has writing on it but is incomplete or on its face contains an
22 invalid signature or which is partially crossed out shall be considered an
23 entry to be included in this count.
- 24 22.3.3 Verification of petitions.
- 25 (a) Each reason for rejection of an entry shall be recorded by separate code
26 and a master record of the rejected entries shall be maintained. A master
27 record shall also be maintained of each entry that is accepted.
- 28 (b) Each section shall be checked for evidence of disassembly. If it appears
29 that the section was disassembled, all entries in the section shall be
30 rejected.
- 31 (c) The circulator's affidavit shall be checked for each entry. If the affidavit
32 is not attached and completed, all entries in the section shall be rejected.
- 33 (d) The notary clause at the end of the affidavit shall be checked for each
34 entry. If any information is missing or if the date on the notary clause is
35 not the same date as the circulator signed the affidavit, all entries in the
36 section shall be rejected.
- 37 (e) Except for initiative petitions, the name of each circulator shall be checked
38 to assure that the circulator was an eligible elector in the political
39 subdivision for which the petition is being circulated at the time that the
40 signatures were gathered. If the circulator was not an eligible elector, all
41 entries in the section shall be rejected.
- 42 (f) If the information on the current voter registration file does not match the
43 information on the entry, the circulator's voter registration history shall be
44 checked to determine if the information on the affidavit matches the voter
45 registration file at the time the affidavit was signed. If the information
46 does not match, all entries in the section shall be rejected.

- 1 (g) In accordance with the decision of the United States Supreme Court in
2 Buckley v. American Constitutional Law Foundation, 520 U.S. 182
3 (1999), circulators of statewide initiative petitions are not required to be
4 registered electors, but such circulators must still be “electors”, which
5 means that they must be (1) residents of the State of Colorado, (2) citizens
6 of the United States, and (3) at least 18 years of age. If there is sufficient
7 evidence to conclude that the circulator was not an elector at the time any
8 signature was gathered, all entries in the section shall be rejected.

9 22.3.4 Checking individual signatures.

- 10 (a) Each individual entry shall be checked against the master voter
11 registration files to assure that the elector was an eligible elector in the
12 political subdivision at the time the petition was signed.
- 13 (b) If the information on the current voter registration file does not match the
14 information on the entry, the elector’s voter registration history shall be
15 checked to determine if the information on the entry matches the voter
16 registration file at the time the entry was signed.
- 17 (c) Name of eligible elector: to be accepted, the name on the entry must be in
18 a form similar to that found on the voter registration record. Signatures
19 that are common variants of the name found on the voter record shall be
20 counted. If the signer of the petition is not found on the voter registration
21 file, or if applicable the county assessors’ list, the entry shall be rejected.
- 22 (d) Middle initial and additional terms.
- 23 (I) If the middle initial or middle name is not part of either the
24 signature line or the voter record but is included on the other
25 document, if the first and last name are the same on both
26 documents, the entry shall be accepted.
- 27 (II) If the middle initial or middle name on the signature line is
28 different than the middle initial or middle name on the voter
29 record, the entry shall be rejected.
- 30 (III) If an indicator such as Jr., Sr., or II is present or omitted from the
31 petition or the voter record, the entry shall be accepted. If two
32 persons with the same name reside at the same address as found on
33 the master voter list, the entry shall be rejected, unless the identity
34 of the signer can be conclusively determined.
- 35 (e) Address of eligible elector.
- 36 (I) If the address written on the line does not match the address on the
37 voter record or on the voter history for the date when the signature
38 was taken, the entry shall be rejected.
- 39 (II) If the address on the petition either includes or omits a letter or
40 number identifying an apartment or the directional location of a
41 street, such as “E” for east, “SW” for southwest, etc., the entry
42 shall be accepted.
- 43 (III) If the signer gave a post office box for the address, the entry shall
44 be rejected.
- 45 (f) Incomplete information: if the line of the petition is incomplete, with at
46 least one piece of information omitted, the entry shall be rejected.

- 1 (g) Date of signing.
2 (I) If a signature is placed on the petition prior to the final approval of
3 the petition format by the designated election official, the entry
4 shall be rejected.
5 (II) If the signer was not an eligible elector in the political subdivision
6 at the time of signing, the entry shall be rejected.
7 (III) If a signature is placed on the petition after the date on the
8 circulator's affidavit, the entry shall be rejected.
9 (h) Assistance to signer: if assistance appears to have been given to the signer
10 and a statement of assistance does not accompany the signature or mark
11 explaining the variance in the script, the entry shall be rejected.
12 (i) Illegible signature: if the signature and printed name are illegible so that
13 the voter record cannot be verified, the entry shall be rejected.
14 (j) Duplicate signature: if the elector has previously signed the same petition,
15 the first valid entry shall be counted and all other entries shall be rejected.
16 (I) Where an elector may sign more than one petition, the first
17 signature(s) filed up to the maximum allowed, shall be the ones
18 that are counted.

19 22.3.5 Final Tally: After all of the sections have been checked, a final tally of all valid
20 signatures shall be prepared and the statement of sufficiency or insufficiency
21 issued.

22 22.4 Statement of sufficiency or insufficiency.

23 22.4.1 Within the time required by statute, the designated election official shall issue a
24 statement of sufficiency or insufficiency.

25 22.4.2 The statement shall contain the name of the petition, the proponents, and the date
26 the petition was submitted for verification.

27 22.4.3 The statement shall indicate the total number of entries, the total number of
28 entries accepted, and the total number of entries rejected.

29 22.4.4 Records: The designated election official shall assure that a record of all
30 signatures rejected and the reasons for each rejection be maintained as public
31 records.

32 **Rule 23. Rules Concerning Referendum Petitions. 1-40-132 C.R.S.; 1-1-107(2)(a)**
33 **C.R.S.**

34 23.1 Applicability. This Rule 23 applies to statewide referendum petitions pursuant to Article
35 V, Section 1 (3) of the Colorado Constitution.

36 23.2 Relationship to statutory and constitutional provisions.

37 23.2.1 The purpose of this Rule 23 is to administer and interpret, but not supersede, the
38 provisions of Article V, Section 1, Colorado Constitution, and Article 40 of Title
39 I, Colorado Revised Statutes, that apply to referendum petitions.

40 23.2.2 Where there is an irreconcilable conflict between this Rule 23 and any such
41 statutory or constitutional provision, then such statutory or constitutional
42 provision prevails.

43 23.3 Applicability of initiative statutes.

44 23.3.1 Except where this Rule 23 otherwise provides, or where the context otherwise
45 requires, any statutory or constitutional provision that applies specifically to
46 initiative petitions shall also apply to referendum petitions.

- 1 23.3.2 The following procedural steps that apply to initiative petitions do not apply to
2 referendum petitions:
3 a. Review and comment by legislative staff on the text of proposed initiated
4 constitutional amendments and initiated laws, pursuant to Article V,
5 Section 1 (5), Colorado Constitution, and Section 1-40-105, C.R.S.
6 b. Title-setting by the title setting review board established in Section 1-40-
7 106, C.R.S.
- 8 23.4 Approval of referendum petition form.
- 9 23.4.1 No referendum petition shall be printed, published, or otherwise circulated unless
10 the form and the master original to be used for printing or reproduction have been
11 approved by the Secretary of State. 1-40-113(1) C.R.S.
- 12 23.4.2 A referendum petition may be submitted to the Secretary of State for approval at
13 any time after the bill has been presented to the governor for approval or
14 disapproval. The Secretary of State shall not issue final approval of the
15 referendum petition form until the bill has become law pursuant to Article IV,
16 Section 11 of the Colorado Constitution.
- 17 23.4.3 Each referendum petition section shall consist of the following, in the order listed:
18 1-40-113(1) C.R.S.; 1-40-102(6) C.R.S.
19 a. The warning as specified in Section 1-40-110, C.R.S.
20 b. The heading "Referendum Petition", followed by the demand upon the
21 Secretary of State in substantially the following form, in which the
22 underlined material is only for example:
23 "To: The Honorable _____, Secretary of State of the State of Colorado
24 We, the undersigned electors of the State of Colorado, do hereby respectfully petition,
25 order, and demand that
26 Sections 1 to 12, inclusive (being the entire Act), of House Bill No. 02-1010, by
27 Representatives Abel, Baker, and Cain, and Senators Smith, Thomas, and Jones, entitled
28 "Concerning registration requirements for motor vehicles, and, in connection therewith,
29 authorizing two- and five-year registration periods and authorizing discretionary vehicle
30 identification number inspections, and making an appropriation", passed by the Sixty-
31 third General Assembly of the State of Colorado, at its regular session in the year
32 2002, shall be submitted to the voters for their adoption or rejection at the next biennial
33 regular general election, to be held on Tuesday, the 5th day of November, 2002, and each
34 of the signers of this petition says:
35 I sign this petition in my own proper person only, and I am a registered elector of the
36 State of Colorado, my residence address and the date of my signing this petition are
37 correctly written immediately after my name, and I do hereby designate the following
38 persons to represent me in all matters affecting this petition:"
39 c. The name and mailing address of two persons who are designated to
40 represent the signers thereof in all matters affecting the same.
41 d. The ballot title and submission clause in the form required by this Rule 23.
42 e. The text of the Act, or the item(s), section(s), or part(s) of the Act, on
43 which the referendum is demanded. 1-40-110; 1-40-102(6)
44 f. Succeeding pages that each contain the warning, the ballot title, and
45 submission clause, and ruled lines numbered consecutively for electors'
46 signatures.

1 g. A final page that contains the circulator’s affidavit required by section 1-
2 40-111 (2), C.R.S., except that, instead of a statement that the circulator is
3 a registered elector, the affidavit shall include a statement that the
4 circulator is a resident of the State of Colorado, a citizen of the United
5 States, and at least 18 years of age. Rule 22.3.3(g)

6 23.4.4 Each referendum petition section shall include only the matters required by
7 Article 40, Title 1, C.R.S., and this Rule 23, and no extraneous material. 1-40-
8 113(1) C.R.S.

9 23.5 Ballot title and submission clause.

10 23.5.1 The ballot title shall consist of the title of the act on which the referendum is
11 demanded, followed by the bill number, in substantially the following form, in
12 which the underlined material is only for example:

13 “An Act concerning registration requirements for motor vehicles, and, in connection
14 therewith, authorizing two- and five-year registration periods and authorizing
15 discretionary vehicle identification number inspections, and making an appropriation,
16 being House Bill No. 02-1010.”

17 23.5.2 When referendum is demanded on less than an entire Act of the General
18 Assembly, the ballot title and submission clause shall consist of the ballot title
19 preceded by words in substantially the following form, in which the underscored
20 material is only for example, and ending in a question mark:

21 “Shall Section 3 (concerning definition of terms) and Section 4 (eliminating licensing
22 requirements for motor vehicle dealers) of the following Act of the General Assembly be
23 approved.” The material in parentheses shall correctly and fairly summarize the subject
24 or the effect of the portion of the Act referenced.

25 23.6 Election. If a referendum petition is timely filed with the Secretary of State with a
26 sufficient number of valid signatures, it shall be voted upon at the next general election
27 that occurs at least three months after the referendum petition is filed with the Secretary
28 of State.

29 **Rule 24. Rules concerning Congressional Term Limits Declaration**

30 24.1 The Secretary of State shall make available to every candidate for United States House of
31 Representatives or the United States Senate the Congressional Term Limits Declaration
32 provided in Article XVIII, Section 12a of the Colorado Constitution. The Secretary of
33 State will offer the Congressional Term Limits Declaration to every such candidate when
34 the candidate files his or her candidate affidavit with the Secretary of State. Any failure
35 of the Secretary of State to offer the Congressional Term Limits Declaration to a
36 candidate shall have no effect on such candidate’s candidacy.

37 24.2 Part A of the Term Limits Declaration shall be accepted by the Secretary of State if Part
38 B of the Term Limits Declaration has not been duly executed and submitted. Art. XVIII,
39 sec. 12a (7)

40 24.3 In the case of a candidate who has qualified as a candidate for a term that would
41 exceed the number of terms set forth in Term Limits Declaration One, the Secretary of
42 State shall not place the words, "Signed declaration to limit service to [3 terms] [2
43 terms]" after the candidate’s name, even if the candidate has executed and submitted
44 Parts A and B of Term Limits Declaration One.

45 **Rule 25. Rules Concerning Uniformed and Overseas Citizens’ Absentee Voting Act**
46 (“UOCAVA”)

- 1 25.1 U.S citizens who are members of the Uniformed Services as defined as the U.S. Armed
2 Forces (Army, Navy, Marines, Air Force and Coast Guard), Merchant Marine, and their
3 spouses or dependants, resident overseas electors, or nonresident overseas electors who
4 are otherwise qualified to apply for and vote by absentee ballot, (“UOCAVA citizens”),
5 may request an absentee ballot by facsimile transmission.
- 6 25.2 A DESIGNATED ELECTION OFFICIAL may send and receive absentee ballot applications by
7 facsimile transmission, send blank ballots and accept voted ballots BY FACSIMILE
8 TRANSMISSION from eligible electors who are UOCAVA citizens and who are otherwise
9 qualified to vote by absentee ballot.
- 10 25.3 IF THE DESIGNATED ELECTION OFFICIAL HAS MAILED A CLARIFICATION FOR VOTER STATUS
11 MEMORANDUM TO AN ELECTOR IN RESPONSE TO RECEIVING AN ABSENTEE BALLOT
12 REQUEST AND HAS NOT RECEIVED A RESPONSE TO THE MEMO AT THE TIME THE ABSENTEE
13 BALLOT PACKET IS PREPARED, THE DESIGNATED ELECTION OFFICIAL SHALL MAIL THE
14 ELECTOR A FULL BALLOT FOR WHICH THE ELECTOR, AS A RESIDENT, WOULD BE ELIGIBLE TO
15 VOTE (FEDERAL, STATE, LOCAL OFFICES AND QUESTIONS).
- 16 25.4 No later than January 1, 2006, the office of each County Clerk and Recorder shall have a
17 dedicated fax machine LOCATED IN THEIR OFFICE in order to send and receive faxed
18 ballots TO AND from UOCAVA citizens in accordance with the Help America Vote Act of
19 2002 and this Rule 25.
- 20 25.4.1 PRIOR TO JANUARY 1, 2006, if the clerk and recorder MAINTAINS a dedicated fax
21 machine, UOCAVA ballots WILL BE FAXED TO THAT LOCAL MACHINE.
- 22 25.4.2 PRIOR TO JANUARY 1, 2006, if the county clerk AND RECORDER does not MAINTAIN
23 a dedicated fax machine, THE CLERK AND RECORDER SHALL BE REQUIRED TO SEND
24 A BALLOT BY FACSIMILE WITH INSTRUCTIONS FOR THE RETURN OF THE BALLOT.
25 The ELECTOR must then fax the voted ballot to the office of the Secretary of State.
26 The Secretary of State shall send the ballot via overnight mail to the appropriate
27 county.
- 28 **Note: This Rule has been incorporated into 25.4 above Note: This Rule has been moved to**
29 **25.11 below**
- 30 25.5 FAXED BALLOT Applications returned via facsimile transmission by
31 the ELECTOR to the county clerk and recorder or the Secretary of State shall be received in
32 the clerk and recorder’s office or the Secretary of State’s office no later than the close of
33 business on the Friday immediately preceding the election.
- 34 25.5.1 Any ballot faxed to an ELECTOR shall contain a unique identification number for
35 tracking and auditing purposes.
- 36 25.6 On the faxed application, the ELECTOR shall provide the fax number, INCLUDING THE
37 INTERNATIONAL COUNTRY CODE AND LOCAL AREA, PROVINCE OR CITY CODE (IF
38 APPLICABLE), WHERE the ballot shall be FAXED.
- 39 25.7 A log shall be kept by the DESIGNATED ELECTION OFFICIAL of each ballot sent to an
40 ELECTOR BY facsimile indicating:
- 41 (A) THE NAME OF THE ELECTOR;
 - 42 (B) THE FAX NUMBER TO WHICH THE BALLOT WAS SENT;
 - 43 (C) THE UNIQUE IDENTIFICATION NUMBER OF THE FAXED BALLOT;
 - 44 (D) THE DATE THE BALLOT AND INSTRUCTIONS WERE FAXED; AND
 - 45 (E) THE INITIALS OF THE EMPLOYEE OF THE DESIGNATED ELECTION OFFICIAL
SENDING THE FAX.

- 1 25.7.1 THE FAX TRANSMISSION LOG AS WELL AS ANY OTHER FAX RECORDS SHALL BE
2 MAINTAINED AS PART OF THE OFFICIAL ELECTION RECORD.
- 3 25.8 ABSENTEE BALLOTS SENT BY FACSIMILE TRANSMISSION SHALL BE IN TEXT FORMAT ON 8 ½”
4 X 11” WHITE PAPER TO INCREASE THE READABILITY OF THE BALLOT AND TO AVOID POSSIBLE
5 MISINTERPRETATIONS OF THE ELECTOR’S INTENDED CHOICE BECAUSE OF POOR
6 TRANSMISSION OF THE DOCUMENT.
- 7 25.9 Instructions faxed to the ELECTOR with the blank ballot SHALL BE IN TEXT FORMAT ON 8
8 ½” X 11” WHITE PAPER AND shall include the following information:
- 9 (a) The DEDICATED fax number to which the voted ballot shall be returned (IF
10 APPLICABLE);
 - 11 (b) The total number of pages transmitted;
 - 12 (c) The total number of ballot pages;
 - 13 (d) THE TELEPHONE NUMBER OR E-MAIL ADDRESS WHERE THE ELIGIBLE
14 ELECTOR MAY SEND QUESTIONS REGARDING THE FAX ABSENTEE BALLOT;
 - 15 (e) A notice that the ballot shall not be duplicated for any other ELECTOR;
 - 16 (f) A notice that once the ballot is returned by an ELECTOR, IT WILL BE
17 COUNTED PURSUANT TO 1-8-116(4) C.R.S.; HOWEVER, IF AN ELECTOR
18 REQUESTS A REPLACEMENT BALLOT, THE FIRST BALLOT RETURNED WILL BE
19 COUNTED PURSUANT TO 1-8-111(3) C.R.S.;
 - 20 (g) A notice that the voted ballot must be received by the clerk and recorder or
21 Secretary of State no later than 7:00 p.m. Mountain Standard Time on
22 election day;
 - 23 (h) A request for an e-mail address to which a confirmation notice of receipt
24 of the ballot may be sent at the discretion of the county clerk and recorder;
25 and
 - 26 (i) Any other information deemed necessary by the Secretary of State or the
27 DESIGNATED ELECTION OFFICIAL.
- 28 **Note: This Rule has been moved to 25.13 below.** 25.10 THE DESIGNATED ELECTION OFFICIAL
29 SHALL FAX A BLANK BALLOT WITH THE INSTRUCTIONS TO THE FAX NUMBER PROVIDED BY
30 THE ELECTOR. IF THE TRANSMISSION IS UNSUCCESSFUL, THE DESIGNATED ELECTION
31 OFFICIAL SHALL ATTEMPT TO FAX THE BALLOT AT LEAST TWO MORE TIMES.
- 32 25.11 An Absentee ballot that is completed and returned by the ELECTOR via facsimile
33 transmission must contain the ELECTOR’s printed name, signature, date of birth, and the
34 following statement: “I am a member of the Uniformed Services, a member of the
35 Merchant Marine, spouse/dependant of a Uniformed Services Member or Merchant
36 Marine, Resident Overseas Elector or a Nonresident Overseas Elector and am qualified to
37 apply for and vote by absentee ballot. I also understand that by faxing my voted ballot, I
38 am voluntarily waiving my right to a secret ballot.”
- 39 25.12 Any voted ballot by a Uniformed Services elector or an overseas elector received by the
40 office of the Secretary of State by 7:00 p.m. Mountain Standard Time on election day
41 shall be forwarded to the appropriate county clerk and recorder by overnight mail, fax, or
42 courier no later than the next business day. The office of the Secretary of State shall
43 immediately notify the appropriate county clerk and recorder of the receipt and
44 forwarding of the ballot.
- 45 25.12.1 IF A COUNTY IS NOTIFIED BY THE SECRETARY OF STATE BY 7:00 P.M. ON ELECTION
46 DAY THAT AN ABSENTEE BALLOT HAS BEEN RECEIVED BY THE OFFICE OF THE

1 SECRETARY OF STATE, THE CLERK AND RECORDER SHALL RETAIN A MINIMUM OF
2 TEN (10) VOTED BALLOTS, WHICH SHALL BE COUNTED WITH THE BALLOT RECEIVED
3 BY THE SECRETARY OF STATE TO ENSURE VOTER SECRECY.

4 25.13 The county clerk and recorder shall report to the Secretary of State's office no later than
5 sixty (60) days from the date of the election:

- 6 a. THE Combined number of absentee ballots transmitted (faxed and mailed)
- 7 b. THE Combined number of absentee ballots that were returned (faxed and
8 mailed);
- 9 c. THE Total number of absentee ballots that were counted (faxed and
10 mailed).

11 **Rule 26. Rules Concerning Provisional Voting**

12 *Note: Unless otherwise noted, stricken text was included in Senate Bill 05-206 and it was
13 therefore unnecessary to repeat it in Election Rules. The Provisional Ballot Rule has
14 been significantly changed to give more clarity to the provisional voting process. The
15 new rule divides the processing of a provisional ballot into various phases for greater
16 clarity.*

17 *Note: Included in New Rule 26. Note: no longer necessary with the repeal of 1-9-304.5.*

18 *Note: The statutes give sufficient direction what information is necessary for registration, and
19 the Provisional Ballot Envelope informs the elector which fields are necessary to fill in.*

20 *Note: New Rule 26 attempts to state more clearly what is needed for verification on the
21 Provisional Ballot Envelope.*

22 *Note: This language is included in new Rule 26. Note: This language is modified and included in
23 new Rule 26. Note: Provisional Ballot Envelope provides space for notation. Note: This
24 procedure is no longer necessary, SB05-206. Note: Incorporated in substantive part into
25 new Rule 26. Note: Modified in SB05-206 and partially included in new Rule 26. Note:
26 Included in modified form in new Rule 26.*

27 *Note: This section was in part incorporated into new Rule 26, and in part was deemed
28 unnecessary because of the guidance provided in the rejection codes contained in
29 the new rule. Note: Incorporated into new Rule 26 in modified form. Note:
30 Included in new Rule 26. Note: This rule has been significantly modified and is
31 included in new Rule 26.*

32 *Note: The challenge process has been clarified and statutory language modified and included in
33 SB 05-206. Note: This section has been incorporated into SB05-206.*

34 *Note: same as above. Note: This rule has been modified based on SB05-206.*

35 **Rule 26. Rules Concerning Provisional Voting**

36 **26.1 GENERAL RULES REGARDING PROVISIONAL VOTING**

37 26.1.1 ELIGIBLE ELECTORS WHO HAVE MOVED WITHIN THE STATE OF COLORADO BEFORE
38 THE REGISTRATION DEADLINE MAY VOTE A PROVISIONAL BALLOT AT THE POLLING
39 PLACE ON ELECTION DAY OR IN THE CLERK AND RECORDER'S OFFICE OR
40 DESIGNATED OFFICES.

41 26.1.2 IF THE PROVISIONAL BALLOT ENVELOPE IS USED AS A VOTER REGISTRATION FORM,
42 IT IS SUBJECT TO THE SAME REQUIREMENTS AS ANY OTHER VOTER REGISTRATION
43 FORM.

44 26.1.3 AN ELECTOR WHO HAS REQUESTED AN ABSENTEE BALLOT SHALL BE PERMITTED TO
45 CAST A PROVISIONAL BALLOT UPON HIS OR HER DECLARATION THAT THEY HAVE

1 NOT AND WILL NOT CAST ANY VOTE IN THE ELECTION OTHER THAN BY THAT
2 PROVISIONAL BALLOT.

3 26.1.4 PROVISIONAL BALLOTS FOR VOTERS WHO HAVE REQUESTED ABSENTEE BALLOTS
4 SHALL BE SEPARATED FROM OTHER PROVISIONAL BALLOTS AND SHALL NOT BE
5 COUNTED UNTIL ALL ABSENTEE BALLOTS CAST IN THE ELECTION HAVE BEEN
6 COUNTED.

7 **26.2 EMERGENCY REGISTRATION AND USE OF PROVISIONAL BALLOTS IN THE COUNTY**
8 **CLERK AND RECORDER'S OFFICE**

9 26.2.1 IF THE ELECTOR APPLIES FOR AN EMERGENCY REGISTRATION THAT CANNOT BE
10 QUALIFIED IN THE CLERK'S OFFICE AT THE TIME OF THE REGISTRATION PURSUANT
11 TO 1-2-217.5(4) C.R.S., THE ELECTOR SHALL BE ISSUED A PROVISIONAL BALLOT.
12 THE ELECTOR'S REGISTRATION MUST BE CONFIRMED BY THE DESIGNATED ELECTION
13 OFFICIAL AT THE TIME THAT THE PROVISIONAL BALLOTS ARE VERIFIED OR THE
14 PROVISIONAL BALLOT SHALL NOT BE COUNTED. *Note: This Rule was previously*
15 *Rule 26.7.3 and was modified and relocated in order to emphasize that emergency*
16 *registration takes place in the county clerk and recorder's office, not the polling*
17 *place.*

18 26.2.2 IF AN ELECTOR **WHOSE NAME IS NOT IN THE REGISTRATION RECORDS**, APPEARS IN
19 PERSON AT THE COUNTY CLERK AND RECORDER'S OFFICE AND STATES THAT HE OR
20 SHE HAS TIMELY REGISTERED THROUGH A VOTER REGISTRATION DRIVE ("VRD")
21 OR AN AGENCY PURSUANT TO 1-2-504 C.R.S. AND HAS BOTH AN APPLICATION
22 RECEIPT AND AN ID AS DEFINED IN 1-1-104(19.5) C.R.S. THE ELECTOR SHALL BE
23 OFFERED EMERGENCY REGISTRATION AND BE OFFERED A REGULAR BALLOT.

24 26.2.2.1 IF THE ELECTOR DOES NOT PROVIDE AN ID AND/OR AN APPLICATION
25 RECEIPT, THE ELECTOR SHALL BE OFFERED A PROVISIONAL BALLOT. THE
26 COUNTY CLERK AND RECORDER SHALL NOTE ON THE PROVISIONAL BALLOT
27 ENVELOPE THAT THE ELECTOR DID NOT HAVE AN ID OR AN APPLICATION
28 RECEIPT.

29 26.2.2.2 IF THE ELECTOR IS ABLE TO PRODUCE AN APPLICATION RECEIPT
30 FROM THE VRD OR AGENCY REGISTRATION, BUT DOES NOT PROVIDE AN ID
31 PURSUANT TO 1-1-104(19.5) C.R.S., THE ELECTOR SHALL SURRENDER THE
32 RECEIPT TO THE ELECTION JUDGE, AND THE COUNTY CLERK AND RECORDER
33 SHALL ATTACH THE RECEIPT TO THE PROVISIONAL BALLOT ENVELOPE.

34 26.2.2.3 IF THE ELECTOR'S ELIGIBILITY TO VOTE CANNOT BE VERIFIED, THE
35 PROVISIONAL BALLOT SHALL NOT COUNT, BUT MAY CONSTITUTE A
36 REGISTRATION FOR FUTURE ELECTIONS.

37 **26.3 PROVISIONAL VOTING IN THE POLLING PLACE**

38 26.3.1 IF THE ELECTOR DOES NOT PROVIDE A DATE IN THE "PREVIOUS RESIDENCE
39 INFORMATION" SECTION OF THE PROVISIONAL BALLOT ENVELOPE STATING WHEN
40 THE ELECTOR MOVED TO THE ADDRESS HE OR SHE LISTED AS HIS OR HER LEGAL
41 RESIDENCE ON THE PROVISIONAL BALLOT ENVELOPE, THE DESIGNATED ELECTION
42 OFFICIAL SHALL ATTEMPT TO VERIFY THE PROVISIONAL BALLOT. IF THE
43 PROVISIONAL BALLOT CAN BE VERIFIED, IT SHALL BE COUNTED. IF IT CANNOT BE
44 VERIFIED, IT SHALL NOT BE COUNTED.

45 26.3.2 IF THE ELECTOR WHOSE NAME DOES NOT APPEAR ON THE POLLBOOK STATES THAT
46 HE OR SHE APPLIED TO REGISTER TO VOTE PRIOR TO THE CLOSE OF REGISTRATION

1 WITH A VRD OR AGENCY PURSUANT TO 1-2-504 C.R.S., THE ELECTION JUDGE
2 SHALL:

- 3 • OFFER THE ELECTOR A PROVISIONAL BALLOT;
- 4 • ASK THE ELECTOR TO SURRENDER THE APPLICATION RECEIPT;
- 5 • CHECK THE BOX ON THE PROVISIONAL BALLOT ENVELOPE INDICATING THAT THE
6 VOTER IS A VRD OR AGENCY APPLICANT, AND
- 7 • ATTACH THE RECEIPT TO THE OUTSIDE OF THE PROVISIONAL BALLOT ENVELOPE.

8 26.3.3 THE WORD “PROVISIONAL” SHALL BE MARKED ON THE PROVISIONAL BALLOT AND
9 ON THE POLLBOOK OR SIGNATURE CARD NEXT TO THE ELECTOR’S NAME.

10 26.4 VERIFICATION OF PROVISIONAL BALLOTS

11 26.4.1 WHEN THE DESIGNATED ELECTION OFFICIAL HAS CONCLUDED THAT ALL VOTED
12 PROVISIONAL BALLOTS HAVE BEEN DELIVERED TO AND RECEIVED BY THE ELECTION
13 OFFICE, THE DESIGNATED ELECTION OFFICIAL SHALL DETERMINE THE TIME THAT
14 PROVISIONAL VERIFICATION AND PROCESSING BEGINS IN ACCORDANCE WITH THE
15 DEADLINES SET FORTH IN TITLE ONE AND THESE RULES. THE DESIGNATED ELECTION
16 OFFICIAL OR DESIGNEE SHALL COMPLETE PRELIMINARY VERIFICATION WITHOUT
17 OPENING THE PROVISIONAL BALLOT ENVELOPES.

18 26.4.2 WHEN VERIFYING PROVISIONAL BALLOTS, THE DESIGNATED ELECTION OFFICIAL
19 MUST CHECK THE COUNTY VOTER REGISTRATION DATABASE TO SEE WHETHER THE
20 ELECTOR HAS ALREADY VOTED IN THE ELECTION.

21 26.4.3 WHEN THE DESIGNATED ELECTION OFFICIAL HAS RECEIVED BOTH AN ABSENTEE
22 BALLOT AND A PROVISIONAL BALLOT FROM AN ELECTOR, BUT THERE IS A
23 DISCREPANCY BETWEEN THE SIGNATURE ON THE RETURNED ABSENTEE BALLOT
24 ENVELOPE AND THE VOTER’S SIGNATURE ON FILE WITH THE COUNTY CLERK AND
25 RECORDER, THE DISCREPANCY MUST BE RESOLVED. BEFORE THE PROVISIONAL
26 BALLOT MAY BE COUNTED, THE ELECTOR MUST AFFIRM THAT THE SIGNATURE ON
27 THE ABSENTEE BALLOT ENVELOPE IS NOT HIS OR HER SIGNATURE. 1-8.5-105(4) AND
28 (5) C.R.S.

29 26.4.4 VERIFICATION OF AN ELECTOR’S ELIGIBILITY TO HAVE HIS OR HER PROVISIONAL
30 BALLOT COUNTED SHALL BE LIMITED TO THE FOLLOWING SOURCES TO DETERMINE
31 PROOF OF VOTER REGISTRATION:

- 32 A. SOURCES PROVIDED BY THE SECRETARY OF STATE OR LAW ENFORCEMENT
33 AGENCIES REGARDING FELONS WHO ARE SERVING A SENTENCE OF DETENTION
34 OR CONFINEMENT OR ON PAROLE;
- 35 B. THE LOCAL ELECTION OFFICE VOTER REGISTRATION DATABASE;
- 36 C. THE SECRETARY OF STATE’S VOTER REGISTRATION DATABASE;
- 37 D. THE DMV MOTOR VOTER DATABASE (NOTE: POSSESSION OF A DRIVER’S
38 LICENSE IS NOT CONCLUSIVE PROOF OF VOTER REGISTRATION; ELECTOR MUST
39 HAVE REGISTERED TO VOTE THROUGH DMV.)

40 **26.4.5 FOR ANY NON-MATCHING OR MISSING SIGNATURE ON A PROVISIONSL BALLOT**
41 **ENVELOPE, RULE 29 CONCERNING PROCEDURES FOR THE VERIFICATION OF**
42 **SIGNATURES SHALL BE FOLLOWED.**

43 26.5 COUNTING OF PROVISIONAL BALLOTS

44 26.5.1 IF THE INFORMATION CONTAINED IN THE PROVISIONAL BALLOT ENVELOPE PROVIDES
45 ADEQUATE CRITERIA SO THAT THE DESIGNATED ELECTION OFFICIAL IS ABLE TO

1 CONFIRM UNDER ELECTION RULE 26 THAT THE ELECTOR IS REGISTERED, THE
2 PROVISIONAL BALLOT SHALL COUNT.

3 26.5.2 PURSUANT TO 1-2-509(3), IF THE DESIGNATED ELECTION OFFICIAL RECEIVES A
4 PROVISIONAL BALLOT FROM A VOTER WHO REGISTERED TO VOTE BUT HAD AN
5 INCOMPLETE OR DEFICIENT VOTER REGISTRATION APPLICATION, AND DID NOT
6 SUPPLY THE REQUIRED INFORMATION AT THE TIME OF REGISTRATION, AT ANY TIME
7 PRIOR TO VOTING, OR ON THE PROVISIONAL BALLOT ENVELOPE, THE PROVISIONAL
8 BALLOT SHALL NOT BE COUNTED. IF THE VOTER DOES SUPPLY THE REQUIRED
9 INFORMATION PRIOR TO OR AT THE TIME OF VOTING, THEN THE PROVISIONAL
10 BALLOT MAY BE COUNTED.

11 26.5.3 ACCEPTANCE CODES (ANY PROVISIONAL BALLOT GIVEN AN ACCEPTANCE CODE
12 SHALL BE COUNTED. HOWEVER CODES ADB, AEJ & AFS APPLY UNDER THOSE
13 CIRCUMSTANCES WHERE ONLY THE STATE AND FEDERAL RACES, ISSUES AND
14 QUESTIONS UPON WHICH THE ELECTOR MAY VOTE SHALL BE COUNTED):

15 AOK REVIEWED AND CONFIRMED VOTER'S ELIGIBILITY.

16 ADB ELECTION OFFICIAL IS KNOWLEDGEABLE THAT THE ELECTOR WAS
17 ERRONEOUSLY SENT TO THE WRONG PRECINCT OR ERRONEOUSLY GIVEN THE
18 WRONG BALLOT STYLE IN THE ELECTOR'S CORRECT PRECINCT. VOTED
19 BALLOT WILL BE DUPLICATED AND ONLY RACES AND ISSUES FOR WHICH THE
20 ELECTOR IS QUALIFIED TO VOTE SHALL BE COUNTED.

21 AEJ ELECTION JUDGE WHO WAS APPOINTED AFTER CLOSE OF EARLY AND
22 ABSENTEE VOTING AND IS WORKING OUTSIDE HIS OR HER PRECINCT; JUDGE
23 SHALL VOTE ON A BALLOT IN THE PRECINCT IN WHICH HE OR SHE IS
24 WORKING; VOTED BALLOT WILL BE DUPLICATED SO THAT ONLY THE RACES
25 AND ISSUES FOR WHICH THE JUDGE IS QUALIFIED TO VOTE SHALL BE
26 COUNTED.

27 AAB VOTER APPEARED IN PERSON AND AFFIRMED UNDER OATH THAT HE OR SHE
28 APPLIED FOR AN ABSENTEE BALLOT BUT HE OR SHE HAS NOT AND WILL NOT
29 CAST THE ABSENTEE BALLOT. THE DESIGNATED ELECTION OFFICIAL SHALL
30 DETERMINE THAT VOTER DID NOT PREVIOUSLY CAST AN ABSENTEE BALLOT
31 FOR THAT ELECTION PURSUANT TO RULE 26.

32 ACP VOTER MOVED FROM THE COUNTY IN WHICH THE VOTER WAS REGISTERED
33 TO ANOTHER COUNTY IN THE STATE NOT LESS THAN THIRTY DAYS BEFORE
34 THE ELECTION AND VOTED IN THE CORRECT PRECINCT IN THE NEW COUNTY
35 OF RESIDENCE. VOTER'S ADDRESS WILL BE UPDATED. 1-8.5-107(2)(A) C.R.S.

36 AFS VOTER IS REGISTERED IN THE COUNTY BUT IS VOTING IN THE WRONG
37 PRECINCT OR THE VOTER MOVED FROM THE COUNTY IN WHICH THE VOTER
38 WAS REGISTERED TO ANOTHER COUNTY IN THE STATE LESS THAN THIRTY
39 DAYS BEFORE THE ELECTION. ONLY THE VOTES FOR FEDERAL AND
40 STATEWIDE OFFICES AND STATEWIDE BALLOT ISSUES AND QUESTIONS UPON
41 WHICH THE VOTER MAY VOTE SHALL BE COUNTED. 1-8.5-108(2) C.R.S.

42 AVD VOTER REGISTERED THROUGH A VOTER REGISTRATION DRIVE AND THE
43 APPLICATION RECEIPT WAS SURRENDERED TO THE ELECTION JUDGE.

44 AAG VOTER REGISTERED THROUGH AN AGENCY AND APPLICATION RECEIPT WAS
45 SURRENDERED TO ELECTION JUDGE.

1 ARD VOTER HAD DEFICIENT OR INCOMPLETE REGISTRATION. THE REQUIRED
2 INFORMATION WAS PROVIDED BY VOTER ON THE PROVISIONAL BALLOT
3 ENVELOPE. VOTER'S REGISTRATION WILL BE AMENDED AND REGISTRATION
4 WILL BE COMPLETE. 1-2-509(3)

5 26.5.4 REJECTION CODES (ANY BALLOT GIVEN A REJECTION CODE SHALL NOT BE
6 COUNTED):

7 RFS (REJECTION FEDERAL OR STATE) NO FEDERAL OR STATE CANDIDATES OR
8 ISSUES TO DUPLICATE.
9 RNS (REJECTION NOT SIGNED) PROVISIONAL BALLOT AFFIDAVIT NOT SIGNED.
10 RIN (REJECTION INCOMPLETE INFORMATION PROVIDED) REQUIRED
11 INFORMATION IS INCOMPLETE AND THE DESIGNATED ELECTION OFFICIAL IS
12 UNABLE TO CONFIRM VOTER'S ELIGIBILITY.
13 RNR (REJECTION NOT REGISTERED) VOTER DID NOT REGISTER BY THE VOTER
14 REGISTRATION DEADLINE OR BY EMERGENCY REGISTRATION, COLORADO
15 VOTER REGISTRATION RECORD WAS NOT FOUND, OR VOTER WAS
16 PREVIOUSLY CANCELLED AND HAS NOT BEEN REINSTATED PURSUANT TO 1-
17 2-605(10). C.R.S.
18 REE (REJECTION ENVELOPE EMPTY) PROVISIONAL BALLOT ENVELOPE IS EMPTY.
19 RAB (REJECTION VOTER VOTED ABSENTEE) Designated election official has
20 confirmed that VOTER VOTED AN ABSENTEE BALLOT.
21 REV (REJECTION BASED ON BALLOT CAST IN EARLY VOTING) VOTER VOTED
22 EARLY.
23 RIP (REJECTION BASED ON INCORRECT PARTY) INCORRECT PARTY IN PRIMARY
24 ELECTION.
25 RFE (REJECTION FELON NOT ELIGIBLE TO VOTE) INDIVIDUAL WAS CONVICTED OF
26 A FELONY AND IS EITHER SERVING A SENTENCE OF CONFINEMENT OR
27 DETENTION OR IS ON PAROLE.
28 RWC (REJECTION ELECTOR NOT REGISTERED IN COUNTY OR STATE OF
29 COLORADO) Non-COUNTY OR NON-STATE RESIDENT; THEREFORE VOTER
30 NOT ELIGIBLE TO VOTE IN THE COUNTY WHERE THE PROVISIONAL BALLOT
31 WAS VOTED.
32 RID (REJECTION FIRST TIME VOTER HAS NOT SUPPLIED IDENTIFICATION UPON
33 REGISTRATION OR THEREAFTER PRIOR TO AND DURING TIME VOTER VOTED)
34 FIRST TIME VOTER WHO REGISTERED BY MAIL OR THROUGH A VOTER
35 REGISTRATION DRIVE, IS TAGGED AS ID DEFICIENT, AND DID NOT PROVIDE ID
36 AT THE TIME OF VOTING.
37 RRD (REJECTION REGISTRATION DEFICIENT) VOTER HAD DEFICIENT OR
38 INCOMPLETE REGISTRATION AND REQUIRED INFORMATION WAS NOT
39 PROVIDED PRIOR TO OR AT THE TIME OF FILLING IN THE PROVISIONAL
40 BALLOT ENVELOPE. VOTER'S ELIGIBILITY CANNOT BE ESTABLISHED. 1-2-
41 509(3) C.R.S.

42 26.6 THE PROVISIONAL BALLOT LOG REQUIRED BY 1-8.5-110 (4) C.R.S. MAY BE PREPARED BY
43 THE DESIGNATED ELECTION OFFICIAL IN HANDWRITTEN OR COMPUTER-GENERATED FORM.

44 26.7 RECOUNT PROCEDURES FOR PROVISIONAL BALLOTS SHALL BE THE SAME AS THE RECOUNT
45 PROCEDURES FOR ABSENTEE BALLOTS AS DIRECTED BY THE SECRETARY OF STATE.

1 **26.8** PURSUANT TO 1-8.5-102(2) C.R.S., THE PROVISIONAL BALLOT AFFIDAVIT SHALL
2 CONTAIN THE FOLLOWING LANGUAGE:
3 **I DO SOLEMNLY AFFIRM THAT I AM A CITIZEN OF THE UNITED STATES, THAT I HAVE**
4 **ATTAINED THE AGE OF EIGHTEEN YEARS, AND THAT I HAVE RESIDED IN THE STATE OF**
5 **COLORADO AND IN MY PRESENT PRECINCT AT LEAST THIRTY DAYS BEFORE THE**
6 **ELECTION, OR AT MY CURRENT RESIDENCE ADDRESS SINCE THE DATE I MOVED AS**
7 **SHOWN ABOVE. I FURTHER AFFIRM THAT THE ADDRESS INDICATED IN THIS AFFIDAVIT**
8 **IS MY SOLE LEGAL RESIDENCE AND THAT I CLAIM NO OTHER PLACE AS MY LEGAL**
9 **RESIDENCE. I AFFIRM THAT IF I APPLIED FOR AN ABSENTEE BALLOT I HAVE NOT AND**
10 **WILL NOT CAST THE ABSENTEE BALLOT THAT I REQUESTED. I FURTHER AFFIRM**
11 **UNDER PENALTY OF LAW THAT I HAVE NOT AND WILL NOT CAST ANY VOTE IN THIS**
12 **ELECTION EXCEPT BY THE ENCLOSED BALLOT, THAT I WILL NOT VOTE IN ANY OTHER**
13 **PRECINCT, COUNTY OR STATE, AND THAT MY BALLOT IS ENCLOSED IN ACCORDANCE**
14 **WITH THE PROVISIONS OF THE “UNIFORM ELECTION CODE OF 1992”, ARTICLE 1 TO 13**
15 **OF TITLE 1, C.R.S.**

16 **26.9** PURSUANT TO 1-8.5-103, C.R.S., THE SIZE OF THE PROVISIONAL BALLOT ENVELOPE
17 SHALL BE IN SUCH A MANNER AS TO PROVIDE TO THE ELECTOR COMPLETE AND
18 LEGIBLE INFORMATION AS SHOWN ON THE STATE APPROVED FORM. ANY ALTERATIONS
19 TO THE STANDARD FORMAT SHALL BE SUBMITTED TO THE SECRETARY OF STATE
20 PURSUANT TO THE POLICY STATEMENT CONCERNING SECRETARY OF STATE APPROVED
21 FORMS.

22 **Rule 27. Rules Concerning Uniform Ballot Counting Standards**

23 27.1 Definitions

24 27.1.1 Blank Ballot. A blank ballot is one on which the voter has made no marks in any
25 voting position, or has been marked with an unreadable marker, or is one which
26 has been consistently marked outside of the “read” area of the scanner.

27 27.1.2 Chad. Chad is the small piece of paper or cardboard produced from a punch card
28 ballot when a voter pierces a hole in a perforated, designated position on the
29 ballot with a marking device to record the voter’s candidate, question, or issue
30 choice.

31 27.1.3 Damaged Ballot. A damaged ballot is one that has been torn, bent, or otherwise
32 mutilated or rendered unreadable, so that it cannot be processed by the optical
33 scanner ballot reader.

34 27.1.4 Duplicated Ballot. A duplicated ballot is one for which a true copy is made in
35 order to be properly processed and counted due to damage, improper marking or
36 some other reason which would prevent a ballot tabulating machine from
37 accurately counting the ballot.

38 27.1.5 DUPLICATED PROVISIONAL BALLOT. A DUPLICATED PROVISIONAL BALLOT
39 INCLUDES BALLOTS DUPLICATED FOR FEDERAL AND STATE ISSUES FOR WHICH A
40 PROVISIONAL VOTER IS ELIGIBLE TO VOTE.

41 27.1.6 Punch Card Ballot. A punch card ballot is a ballot card that contains small
42 perforated design positions that a marking device must pierce to form a hole that
43 records a voter’s candidate, question, or issue choice.

44 27.1.7 Overvote. An overvote is a race, question or issue which contains votes for more
45 than the maximum number of candidates or responses for a ballot question or
46 issue allowed.

- 1 27.1.8 Undervote. An undervote occurs when the voter does not vote for a candidate,
2 question, or issue, or when more than one person in a race is available, the voter
3 does not vote for the maximum number of votes allowed.
- 4 27.1.9 Vote in Optical Scan Ballots. A correctly voted optical scan ballot occurs when a
5 voter, using a readable marker, fills in or connects the minimum number of
6 ovals/arrows per race, question, or issue, not to exceed the maximum allowable
7 votes per race, question or issue, without extending the vote mark beyond the
8 parameters of the instructions.
- 9 27.1.10 Write-In Vote. A vote on a ballot on which the voter physically writes in
10 the name of a legally qualified write-in candidate in the space reserved on the
11 ballot for write-in votes and properly marks the oval or connects the arrow on
12 optical scan ballots according to the directions provided to the voter.
- 13 27.2 Uniform Counting Standards for HAND-COUNTED Paper Ballots
- 14 27.2.1 Judges counting ballots on election day shall take into consideration the intent of
15 the voter.
- 16 27.2.2 If a ballot contains markings for more than the maximum votes allowed in a
17 candidate race or for a ballot issue or question, no vote shall count for that race,
18 question, or issue. Judges shall take into consideration any notation by the voter
19 that would clearly indicate the choice of the voter.
- 20 27.2.3 If an issue, question or candidate race contains no markings by the voter, no tally
21 will be made for that race, question, or issue, but all other candidate races, issues,
22 or questions properly marked by the voter on the ballot shall be counted.
- 23 27.2.4 A ballot which has no markings for any candidate races, issues or questions shall
24 be tallied as a blank ballot, but the voter shall be given credit for voting.
- 25 27.2.5 If the intent of the voter is clear on a write-in vote, the write-in vote shall be
26 counted for a legally qualified candidate.
- 27 27.3 Uniform Counting Standards for Optical Scan Ballots
- 28 27.3.1 Precinct Optical Scan Procedures
- 29 (a) Voters whose ballots are rejected or sorted by the precinct counter as a
30 blank or overvoted ballot shall be given the opportunity to correct their
31 ballot.
- 32 (b) Ballots sorted to a write-in bin shall be tallied at the conclusion of the
33 voting and delivered to the central COUNTING center in a secure container.
- 34 27.3.2 Central Count Optical Scan Procedures
- 35 (a) A resolution board, consisting of a team(s) of one (1) Republican and one
36 (1) Democrat for partisan elections or two (2) qualified election judges for
37 nonpartisan elections, shall resolve all ballots sorted by the central count
38 optical scan equipment.
- 39 (2) The board shall be observed by two (2) witnesses, who in any
40 partisan election shall be representatives of each major political
41 party, who may not handle or process ballots.
- 42 (3) All persons engaged in the counting and processing of ballots shall
43 be deputized or take an oath to faithfully perform their duties.
- 44 (4) The resolution board shall maintain a log for each step of
45 verification, duplication, and counting according to Rule 11.5.8.
- 46 (b) Sequence of Resolution Procedures

- 1
2
3
4
5
6
7
8
9
10
11
12
13
14
15
16
17
18
19
20
21
22
23
24
25
26
27
28
29
30
31
32
33
34
35
36
37
38
39
40
41
42
43
44
45
46
- (1) A zero tape shall be run indicating no votes cast or counted before the counting begins.
 - (2) Official ballots shall be processed through the optical scanner, with sorted overvotes, blank ballots, and write-in ballots viewed and resolved by the resolution board. **ONLY BALLOTS SORTED BY THE MACHINE SHALL BE SUBJECT TO REVIEW BY THE RESOLUTION BOARD.** If there are no legally qualified write-in candidates, the write-in sort option shall not be utilized. The number of each duplicated ballot shall be entered on the resolution board log sheet.
 - (3) All ballots which are sorted by the optical scanner and resolved by the resolution board by duplication are to be indicated as such and kept separate from the standard run ballots for the precinct.
 - (4) The precinct judge's ballot RECONCILIATION form is compared to the number of scanned ballots for the precinct.
 - (5) After the final precinct has been tallied, the total write-in votes shall be indicated on the final summary along with the seal numbers for each sealed box of scanned ballots.
- (c) Resolution of optical scan ballots
- (1) Damaged or defective ballots shall be duplicated utilizing the ballot duplication procedures as provided in Rule 27.3.3(c)(5).
 - (2) Blank ballots shall be examined by the resolution board to determine if the ballot is a true blank ballot or one that has been marked with a non-detectable mark. Resolution board members must make a duplicate copy of the ballot which has been marked with a non-detectable mark utilizing the ballot duplication procedures as set forth in Rule 27.3.3(c)(5). If a ballot is truly blank it shall be sent back for the resolution pass through the scanner, and the ballot tabulated with no races, issues or questions voted.
 - (3) Overvoted ballots shall be inspected by the resolution board. Ballots that reflect marks that are clearly identified as unintentional but register an overvote on the scanner must be duplicated by the resolution board utilizing the procedures for duplication of ballots. **IF MORE MARKS ARE COMPLETED IN A RACE, QUESTION, OR ISSUE THAN WHAT IS ALLOWED FOR THAT RACE, QUESTION, OR ISSUE THE DUPLICATION BOARD CAN ONLY DUPLICATE IF THERE IS A NOTATION BY THE VOTER THAT WOULD CLEARLY INDICATE THE CHOICE OF THE VOTER.**
 - (4) Write-in votes sorted by the optical scan equipment on election day shall be delivered to the assigned write-in board for hand counting. In order to be counted, the oval must be darkened or the arrow connected according to the appropriate voting instructions. Only votes for legally qualified write-in candidates shall be counted. **WHEN A RACE WITH A VALID WRITE-IN IS OVERVOTED AND THE DUPLICATION BOARD FINDS THAT A MARK HAS BEEN MADE FOR A VALID CANDIDATE AND THE VOTER ALSO WROTE IN THE NAME OF**

1 THE SAME CANDIDATE ON THE WRITE-IN LINE AND MADE A MARK,
2 THE DUPLICATION BOARD SHALL DUPLICATE THE BALLOT BY
3 MAKING A MARK BY THE NAME OF THE CANDIDATE PRINTED ON
4 THE BALLOT.

- 5 (5) The resolution board shall duplicate ballots by clearly labeling the
6 new duplicate ballot as a "DUPLICATE" and assign a serial
7 number which shall be recorded on both the original and duplicate
8 ballot. For example, the first ballot in Precinct # 1 to be duplicated
9 could be labeled as #1/001 with the duplicate labeled D#1/001.
10 Original ballots shall be separated from the duplicate ballots and
11 placed in an envelope clearly marked "ORIGINAL BALLOTS."
12 The duplicate ballots shall be counted in lieu of the original ballots.
- 13 (6) The resolution board shall maintain an official audit log setting
14 forth the PRECINCT NUMBER, duplicate ballot number, reason (with
15 specificity) that the ballot was duplicated, date of duplication, and
16 the initials of the members of the duplication board responsible for
17 duplicating the ballot.

18 (d) Recount Procedures for Optical Scan

- 19 (1) Optical scan equipment must be set to consistent sensitivity
20 standards for each system type, must be tested prior to the recount,
21 and shall be programmed to sort undervotes for the individual
22 race(s), issue(s) or question(s) being recounted.
- 23 (2) Recounts will include a visual inspection of all ballots cast for
24 write-in candidates in the contested race(s) to determine voter
25 intent.

26 27.4 Uniform Counting Standards – Punch Card Voting Systems

27 27.4.1 Inspection of Ballots. Prior to the counting of the ballots by automatic tabulating
28 equipment, at least one team of election personnel, which except in non-partisan
29 elections shall consist of one member from each political party, shall inspect the
30 ballots for loose chad, ballot damage, including holes that are too large, a ballot
31 that is torn in the mail, etc., written instructions and corrections, and write-in
32 votes. The purpose of the inspection shall be to insure that all ballots are
33 machine-readable and that the voter's intent will be recorded correctly and
34 accurately. In some instances, duplication of the ballot may be necessary in order
35 to count the ballot.

- 36 (a) All loose chad shall be removed to ensure that all of the voter's choices on
37 the ballot are correctly and accurately reflected in the count.
- 38 (1) A chad that is unattached on two or more corners represents a vote
39 and shall be removed.
- 40 (2) If a chad is attached to a punch card ballot by three or four corners,
41 no vote shall be recorded for that candidate, issue or question
42 choice at that particular ballot position, and the chad shall not be
43 removed.
- 44 (b) Dimpled mark or puncture on the attached chad.
- 45 (1) If a ballot has been punched according to instructions, but there
46 exists a random dimpled mark or puncture located wholly on the

- 1 non-removed chad, that mark or puncture shall be considered a
2 random mark or puncture.
- 3 (2) If the ballot has NOT been punched according to instructions, but
4 consists of a series of dimpled marks or punctures located wholly
5 on the attached chad, those marks or punctures shall represent the
6 voter's intent to vote for that designated position, and the ballot
7 shall be duplicated accordingly.
- 8 (3) If a dimpled mark or puncture appears on the ballot anywhere
9 other than completely on the chad, voter intent cannot be
10 determined, and the ballot shall be duplicated without that dimple
11 mark or puncture.
- 12 (c) Damaged ballots. If the ballot has damage or defects that would cause
13 problems in tallying, such as a ballot being torn in the mail, the ballot shall
14 be duplicated to the extent possible, evidencing the voter's intent. If the
15 voter's intent cannot be determined for a specific office, issue or question
16 on the damaged ballot, that position shall be left blank on the duplicate
17 ballot.
- 18 (d) Voter instructions. If other material is included with the ballot or is
19 attached to the secrecy envelope, the material shall be inspected to
20 determine if it has a bearing on the voter's intent. If the material has a
21 bearing on the voter's intent, the original ballot shall be duplicated as
22 necessary and the original ballot, along with the material, shall be placed
23 in an envelope marked "Duplicated Ballot." (e) Write-In Votes.
- 24 (1) Write-in votes shall be recorded on the secrecy envelope.
- 25 (2) Only votes cast for legally qualified write-in candidates shall be
26 considered valid and counted. Any write-in votes for candidates
27 who are not legally qualified shall be disregarded and not counted.
- 28 (3) On the punch card secrecy envelope, the voter must indicate both
29 the name of the candidate being written AND the office for which
30 the candidate is running. If either candidate's name or the office
31 for which the candidate is running is left off the secrecy envelope,
32 then the intent of the voter cannot be determined and the vote shall
33 not be counted. If the write-in vote is disregarded, any vote for
34 that office on the punch card ballot itself shall be tabulated and
35 counted.
- 36 (4) If both the office name and the candidate's name are included in
37 the write-in option on the secrecy envelope, the punch card ballot
38 must be checked for any other votes for that office. If the write-in
39 vote does not result in an overvote for that office, then all votes
40 shall be tabulated and counted. If the write-in vote creates an
41 overvote for that office, then neither vote shall be counted, and the
42 punch card ballot shall be duplicated to reflect an overvote.
- 43 (5) If the write-in line contains a name that is the same as the one that
44 is printed on the ballot for that office, regardless of whether the
45 ballot position for that candidate is punched out or not, then the
46 write-in vote shall be disregarded, and the ballot shall be

1 duplicated, if necessary, so that the tabulating machine will count
2 the vote as a vote for the selected candidate.

3 27.4.2 Duplication of Ballots.

- 4 (a) Using the damaged ballot as the guide, a blank ballot shall be marked by a
5 duplicating team, so that the votes recorded are identical to those indicated
6 on the damaged ballot, and shall be proofed to insure that is marked
7 properly and accurately.
- 8 (b) A unique number shall be assigned to both the original and duplicated
9 ballot. This will reference the two ballots together and provide an audit
10 trail. (Example: the ballots may be marked XX-NNN, where XX is the
11 precinct number and NNN are consecutive numbers starting with the
12 number one.)
- 13 (c) The duplicate ballot shall be placed with all other ballots to be counted.
- 14 (d) The damaged or unreadable original ballot shall be marked
15 "DUPLICATED" to indicate that the ballot has been duplicated and the
16 duplication is completed. All duplicated original ballots for a precinct
17 along with any applicable printed material shall be placed in an envelope
18 and clearly marked "BALLOTS THAT HAVE BEEN DUPLICATED."

19 **Rule 28. Rules Concerning Election Judges**

20 28.1 For purposes of training election judges, an "election cycle" shall mean all elections held
21 during a calendar year beginning with January 1 and ending December 31.

22 **Rule 29. Rules Concerning Procedures for the Verification of Signatures**

23 29.1 MISSING SIGNATURE ON MAIL BALLOT, PROVISIONAL BALLOT OR ABSENTEE BALLOT
24 ENVELOPE

25 29.1.1 WHEN THE ELECTION JUDGE REVIEWS THE MAIL BALLOT RETURN ENVELOPE
26 PURSUANT TO 1-7.5-107.3 C.R.S. OR ABSENTEE BALLOT RETURN ENVELOPE
27 PURSUANT TO 1-8-114.5 C.R.S. OR THE PROVISIONAL BALLOT RETURN ENVELOPE
28 PURSUANT TO 1-8.5-105(3)(A), AND NOTICES THAT THE ENVELOPE LACKS A
29 SIGNATURE, THE ELECTION JUDGE SHALL CONTACT THE ELIGIBLE ELECTOR IN
30 WRITING NO LATER THAN TWO CALENDAR DAYS AFTER ELECTION DAY. A COPY OF
31 THE WRITTEN NOTIFICATION SHALL BE KEPT IN AN OFFICIAL FILE, WHICH SHALL
32 BECOME PART OF THE OFFICIAL ELECTION RECORD. NOTHING IN THIS RULE SHALL
33 BE CONSTRUED TO PROHIBIT THE DESIGNATED ELECTION OFFICIAL FROM CALLING
34 THE ELECTOR; HOWEVER, A PHONE CALL SHALL NOT SUBSTITUTE FOR NOTIFICATION
35 TO THE ELECTOR IN WRITING.

36 29.1.2 THE LETTER SHALL INFORM THE ELIGIBLE ELECTOR THAT THEY MUST COME TO THE
37 OFFICE OF THE COUNTY CLERK AND RECORDER TO SIGN THE MAIL BALLOT,
38 PROVISIONAL BALLOT, OR ABSENTEE BALLOT ENVELOPE NO LATER THAN EIGHT (8)
39 CALENDAR DAYS AFTER ELECTION DAY.

40 29.1.3 THE LETTER SENT BY THE ELECTION OFFICIAL SHALL NOT CONSTITUTE A VIOLATION
41 OF 1-13-801 C.R.S.

42 29.1.4 THE LETTER SHALL INCLUDE THE FOLLOWING LANGUAGE:
43 "ANY PERSON WHO KNOWINGLY VIOLATES ANY OF THE PROVISIONS OF THE
44 ELECTION CODE RELATIVE TO THE CASTING OF BALLOTS OR WHO AIDS OR ABETS
45 FRAUD IN CONNECTION WITH ANY VOTE CAST, OR TO BE CAST, OR ATTEMPTED TO BE
46 CAST SHALL BE PUNISHED BY A FINE OF NOT MORE THAN FIVE THOUSAND DOLLARS

1 OR BY IMPRISONMENT IN THE COUNTY JAIL FOR NOT MORE THAN EIGHTEEN
2 MONTHS, OR BY BOTH SUCH FINE AND IMPRISONMENT. 1-13-803 C.R.S.

3 29.2 IN ACCORDANCE WITH 1-8-114.5 C.R.S FOR ABSENTEE BALLOTS AND 1-7.5-107.3 for
4 MAIL BALLOTS , THE ELECTION JUDGES SHALL COMPARE the signature on the self-
5 affirmation ON EACH RESPECTIVE “Return Envelope” shall be compared with the signature
6 on file with the county clerk and recorder or election official. Signatures shall require
7 further research if any of the following differences are discovered:
8 Code 1 – An obvious change in the slant of the signature
9 Code 2 – A printed signature on one document and a cursive signature on the other
10 document
11 Code 3 – Differences in the size or scale of the signature
12 Code 4 – Differences in the individual characteristics of the signatures, such as how the
13 “t’s” are crossed, “I’s” are dotted, loops are made on “Y’s” or “J’s”
14 Code 5 – Differences in the voter’s signature style, such as how the letters are connected
15 at the top and bottom
16 CODE 6 – BALLOTS OR ENVELOPES FROM THE SAME HOUSEHOLD HAVE BEEN SWITCHED
17 CODE 7 – ‘OTHER,’ INCLUDING MISSPELLED NAMES & DESCRIPTION OF DISCREPANCY.

18 29.3 If further research is necessary, the election judge shall check the county clerk’s or
19 election official’s file for at least two additional documents signed by the voter, if
20 available. Additional information, written by the voter on the “Return Envelope”, such as
21 the voter’s address and date of signing may be compared for similarities. Any
22 similarities noted when comparing this other information may be used as part of the
23 signature verification decision process.
24 29.3.1 IF IT APPEARS TO THE JUDGES VERIFYING THE SELF-AFFIRMATION ON THE RETURN
25 ENVELOPES THAT MEMBERS OF THE SAME HOUSEHOLD WHO HAVE APPLIED FOR
26 ABSENTEE BALLOTS OR HAVE BEEN SENT MAIL BALLOTS HAVE INADVERTENTLY
27 SWITCHED ENVELOPES OR BALLOTS, THE BALLOT OR BALLOTS SHALL BE COUNTED
28 AND NO LETTER OF ADVISEMENT TO THE ELECTOR IS NECESSARY.

29 29.4 Whenever a signature is disputed, the election judge shall document the discrepancy by
30 completing a log. The log shall provide a record of the research steps taken to resolve the
31 issue. The log will identify the voter using a unique tracking number. This tracking
32 number shall not contain the voter’s social security number, Colorado issued driver’s
33 license number, or the identification number issued by the Department of Revenue.

34 29.5 The log shall be approved by the Secretary of State pursuant to 1-1-109, C.R.S. (**Note:**
35 **Exactly the same as 13.9.2.4**)

36 29.6 There shall be no document containing the voter’s signature attached to the research log.
37 (**Note: Exactly the same as 13.9.2.5**)

38 29.7 If BOTH SETS of election judges agree that the signatures do not match, THE COUNTY
39 CLERK AND RECORDER SHALL WITHIN TWO DAYS AFTER THE ELECTION, SEND A LETTER TO
40 THE ELIGIBLE ELECTOR AT THE ADDRESS INDICATED IN THE REGISTRATION RECORDS AND
41 THE ADDRESS WHERE THE ABSENTEE OR MAIL BALLOT WAS MAILED EXPLAINING THE
42 DISCREPANCY IN SIGNATURES AND A FORM FOR THE ELIGIBLE ELECTOR TO CONFIRM THAT
43 THE ELECTOR RETURNED A BALLOT TO THE COUNTY CLERK AND RECORDER. (1-7.5-
44 107.3(2)(A), 1-8-114.5(2)(A)). THE VOTED BALLOT ITSELF SHOULD NOT UNDER ANY
45 CIRCUMSTANCES BE RETURNED WITH THIS LETTER.

- 1 29.8 The form of the letter AS WELL AS THE FORM SENT TO THE ELECTOR shall be approved by
2 the Secretary of State pursuant to 1-1-109, C.R.S.
- 3 29.9 THE LETTER SENT BY THE ELECTION OFFICIAL SHALL NOT CONSTITUTE A VIOLATION OF 1-
4 13-801 C.R.S.
- 5 29.10 THE LETTER SHALL INCLUDE THE FOLLOWING LANGUAGE:
6 “ANY PERSON WHO KNOWINGLY VIOLATES ANY OF THE PROVISIONS OF THE ELECTION CODE
7 RELATIVE TO THE CASTING OF BALLOTS OR WHO AIDS OR ABETS FRAUD IN CONNECTION
8 WITH ANY VOTE CAST, OR TO BE CAST, OR ATTEMPTED TO BE CAST SHALL BE PUNISHED BY
9 A FINE OF NOT MORE THAN FIVE THOUSAND DOLLARS OR BY IMPRISONMENT IN THE COUNTY
10 JAIL FOR NOT MORE THAN EIGHTEEN MONTHS, OR BY BOTH SUCH FINE AND IMPRISONMENT.
11 1-13-803 C.R.S.”
- 12 29.11 The final signature verification resolution and ballot disposition shall be noted on the
13 research log.
- 14 29.12 ANY UNCOUNTED BALLOT SHALL REMAIN SEALED IN THE RETURN ENVELOPE AND STORED
15 UNDER SEAL WITH ALL OTHER UNCOUNTED BALLOTS AS PART OF THE ELECTION REOCD
16 PURSUANT TO 1-7-802 C.R.S. AND MAY BE REMOVED ONLY UNDER THE AUTHORITY OF A
17 DISTRICT ATTORNEY OR BY ORDER OF A COURT HAVING JURISDICTION.
- 18 Rule 30. Rules Concerning Voter Identification
- 19 30.1 Definitions
- 20 30.1.1 “Registration in person” means any registration personally completed by the voter
21 at any clerk’s main or branch office or personally delivered by the voter to any
22 clerk’s main or branch office, driver’s license office, or other voter registration
23 agency.
- 24 30.1.2 “Mail Registration” or “Registration by mail” includes any registration not
25 personally delivered by the voter to any clerk’s main or branch office, voter
26 registration agency, driver’s license office, or other human services agency.
27 These registrations include, but are not limited to, postmarked registration forms
28 and voter registration drives.
- 29 30.1.3 As referenced in these rules, “tagging a voter” for ID before voting means
30 identifying a voter in the voter registration database as one who registered by mail
31 and did not supply required identification. Tagged voters require a copy of the
32 required identification to be enclosed with an absentee or mail ballot.
- 33 30.1.4 A tagged voter may present the required voter ID OR A NUMBER WHICH IS
34 SUBSEQUENTLY VERIFIED to the County Clerk and Recorder at any time prior to
35 returning a voted mail or absentee ballot to satisfy the provisions of Rule 30.1.3.
- 36 30.1.5 “SSN” as used in these rules shall mean either the entire Social Security Number
37 or the last four (4) digits of the Social Security Number.
- 38 30.1.6 “ID” as used in these rules shall mean identification as defined in Rules 30.3,
39 30.4, 30.13 and 30.14 in compliance with 1-1-104(19.5) C.R.S.
- 40 30.2 Requirements for providing an ID or ID # and verifying an ID # shall be effective
41 January 1, 2003.
- 42 30.3 Voter registration in person.
- 43 30.3.1 Registering in Person. The elector must provide:
- 44 ● A valid Colorado Driver’s License number; or
45 ● A valid Department of Revenue Identification number; or
46 ● At least the four last digits of the elector’s social security number.

1 Authority: 1-2-204(2)(f.5) C.R.S.

2 30.3.2 A voter is not required to show or present his current and valid Colorado driver's
3 license or ID. It is sufficient for the voter to provide the ID number.

4 30.3.3 In the event the registrant has but refuses to give a CO Driver's License, ID
5 number, and SSN, or the registrant provides only one of these numbers, the
6 registrar shall nevertheless register the voter.

7 30.3.4 Prior to the creation of the statewide voter registration database, if an applicant for
8 voter registration refuses to provide or has not been issued a current and valid
9 Colorado driver's license, or a current and valid identification card issued by the
10 Department of Revenue, or a social security number, the election official shall
11 nevertheless register the voter. The applicant SHALL BE ASSIGNED a unique
12 identification number that will serve to identify the applicant for voter registration
13 purposes. 1-2-204 (2.5) C.R.S.

14 30.4 Voter Registration by Mail

15 30.4.1 Registering by Mail. (Including Voter Registration Drives).

- 16 (a) The elector must provide a copy of one of the ~~following~~ forms of
17 identification set forth in Rule 2.3(a);
- 18 ~~• A valid Colorado driver's license;~~
 - 19 ~~• A valid identification card issued by the department of REVENUE IN~~
20 ~~ACCORDANCE WITH THE REQUIREMENTS OF PART 3 OF ARTICLE 2 OF~~
21 ~~TITLE 42 C.R.S.;~~
 - 22 ~~• A valid U.S. passport;~~
 - 23 ~~• A valid employee identification card with a photograph of the~~
24 ~~eligible elector issued by any branch, department, agency, or entity~~
25 ~~of the United States government or of this state, or by any county,~~
26 ~~municipality, board, authority, or other political subdivision of this~~
27 ~~state;~~
 - 28 ~~• A valid pilot's license issued by the federal aviation administration~~
29 ~~or other authorized agency of the United States;~~
 - 30 ~~• A valid U.S. military identification card with a photograph OF THE~~
31 ~~ELIGIBLE ELECTOR;~~
 - 32 ~~• A copy of a current utility bill, bank statement, government check,~~
33 ~~paycheck, or other government document that shows the name and~~
34 ~~address of the elector. (A cable bill, a telephone bill, or a paycheck~~
35 ~~from a government institution or documentation from a public~~
36 ~~institution of higher education in Colorado containing at least the~~
37 ~~name, date of birth, and LEGAL residence address of the student~~
38 ~~elector, are sufficient forms of ID.); or~~
 - 39 ~~• A valid Medicare or Medicaid card ISSUED BY THE UNITED STATES~~
40 ~~HEALTH CARE FINANCING ADMINISTRATION;~~
 - 41 ~~• A certified copy of a U.S. birth certificate FOR THE ELECTOR ISSUED~~
42 ~~IN THE UNITED STATES; or~~
 - 43 ~~• Certified documentation of naturalization;~~
- 44 (b) Or the elector must provide one of the following identification numbers:
45 At least the last four digits of the person's social security number; or
46 The person's Colorado driver's license number; or

Formatted

1 The number of an identification card issued by the Department of
2 Revenue.
3 Authority: 1-2-501(2)(b) C.R.S.; 1-1-104(19.5) C.R.S.
4 30.4.2 For any Colorado driver's license, number of an identification card issued by the
5 Department of Revenue, ~~or~~ Social Security Number listed on a registration by
6 mail where a copy of the Colorado driver's license, or the identification card is
7 not enclosed with the application, the ID shall be verified against the Department
8 of Motor Vehicle Motor/Voter Database and the Secretary of State voter
9 registration database. When access to the Social Security database becomes
10 available, that database shall also be utilized. IF THE NUMBER CANNOT BE
11 VERIFIED, THE VOTER'S RECORD WILL BE TAGGED. UPON CREATION OF THE
12 STATEWIDE VOTER REGISTRATION SYSTEM, THE CHECK WILL BE PERFORMED
13 AUTOMATICALLY.
14 30.4.3 If, for a registration by mail, a copy of the ID is enclosed per 1-1-104(19.5)
15 C.R.S., no further verification against the Department of Motor Vehicle
16 Motor/Voter Database, the Secretary of State voter registration database and the
17 Social Security database is required. The elector is allowed to vote by mail or
18 absentee ballot without additional identification requirements. 30.4.4
19 Verification shall include a match of name, date of birth and ID number on
20 an existing state identification record. A match of only one or two of these items
21 shall not be considered verification. During verification, names given which are
22 similar common variants or nicknames of the name shall be acceptable.
23 30.4.5 Subject to SOS Election Rules 30.5.5, if the identification number supplied does
24 not match the identification number on the database record for the name and date
25 of birth, the registration by mail shall not be considered verified. However, if the
26 voter has made a minor error, the Clerk and Recorder may use good judgment and
27 correct the error, and consider the voter verified. Minor errors include, but are not
28 limited to, a transposition of two numbers, or accidentally adding or omitting a
29 number.
30 30.5 Verification of Identification:
31 30.5.1 Prior to the creation of the statewide voter registration database, for any ID shown
32 or ID # given for registration in person, the ID is not required to be verified
33 against the Driver's License or SS database.
34 30.5.2 Prior to the implementation of the statewide voter registration database, where a
35 voter lists on a registration by mail a Colorado driver's license number, Colorado
36 ID# number, or the last four digits of a Social Security Number but the voter did
37 not enclose a copy of the Colorado driver's license, or Colorado ID number with
38 the application, the ID shall be verified against the Driver's License and the
39 Secretary of State voter database.
40 30.5.3 Prior to the implementation of the statewide voter registration database, if, for a
41 registration by mail, a copy of the ID is enclosed per 1-1-104(19.5), no further
42 verification pursuant to Rule 26 against the Motor Vehicle Motor/Voter Database,
43 the Secretary of State's voter database or Social Security database is required. The
44 elector is allowed to vote by mail or absentee without additional identification
45 requirements.

- 1 30.5.4 Verification shall include a match of name, date of birth and ID number on an
2 existing state identification record. A match of only one or two of these items
3 shall not be considered verification.
- 4 30.5.5 If the identification number supplied does not match the identification number on
5 the database record for the name and date of birth, the registration by mail shall
6 not be considered verified and the registration record shall be ID tagged.
- 7 30.6 Tagging a voter:
- 8 30.6.1 Only a voter who has registered by mail may be tagged; a person who registers in
9 person shall not be tagged.
- 10 30.6.2 A voter who registers by mail and provides a copy of an acceptable ID as
11 provided in 1-1-104(19.5) shall not be tagged. A SSN card is not listed as ID in
12 1-1-104(19.5).
- 13 30.6.3 If a voter registers by mail and supplies a Colorado driver's license or Colorado
14 Department of Revenue ID number (but not a copy of either) and/or the SSN, and
15 if at least one of the numbers can be verified with an existing state identification
16 record bearing the same number, name and date of birth, the voter shall not be
17 tagged.
- 18 30.6.4 A voter, who does not supply a copy of an acceptable ID as provided in 1-1-
19 104(19.5) or does not list his/her SSN#, the number of his/her Colorado driver's
20 license or Colorado Department of Revenue ID#, shall be tagged.
- 21 30.6.5 If a voter registers by mail and supplies either a Colorado driver's license number
22 or Colorado Department of Revenue ID# (but not a copy of either) and/or SSN,
23 but no number can be verified with an existing state identification record bearing
24 the same number, name and date of birth against the Driver's License database,
25 Secretary of State voter database or Social Security database once access to the
26 Social Security database becomes available, the voter shall be tagged.
- 27 30.6.6 The tag status for a voter shall be removed if the voter votes in person showing a
28 acceptable ID or votes by mail or absentee and encloses a valid ID.
- 29 30.6.7 If the identification number supplied is discovered as incorrect upon verification,
30 the clerk and recorder may enter the correct number, but the voter shall be tagged.
- 31 30.7 If an elector registering by mail does not provide a Colorado Driver's License Number or
32 a Department of Revenue ID# or the last four digits of the elector's SSN on the voter
33 registration application, and the county clerk and recorder discovers such identification
34 number, the clerk and recorder may enter the applicable identification number on the
35 elector's permanent voter registration record. Any number entered on the elector's
36 permanent voter registration record by the clerk and recorder does not remove the tag
37 status of a voter. Such voter is still required to provide valid identification prior to
38 voting.
- 39 30.8 Addresses on identification
- 40 30.8.1 If ID presented lists only a box number or Post Office box number instead of a
41 residence address, the registrar shall accept the voter's affirmation, as long as the
42 city is in Colorado.
- 43 30.8.2 Some forms of identification may not contain an address. If the address appears
44 on the identification, the address must be in Colorado.
- 45 30.8.3 Utility bills, bank statements, government checks, paychecks or other government
46 documents must show THE NAME OF THE ELECTOR and Colorado address.

- 1 **Note: delete as the law has changed.**30.9 A suspended license is considered current and valid.
 2 A revoked or expired license is not considered current and valid and is not acceptable.
 3 30.10 As used in 1-1-104(19.5)(a)(VII) “current” refers to current utility bill, current bank
 4 statement, and current government check, paycheck, or other government document that
 5 shows the name and address of the elector. Current means that the date of the document
 6 is within 60 days of the date submitted for identification purposes unless the document
 7 states a longer billing cycle.
 8 30.11 The Colorado Driver’s License or Department of Revenue issued ID referred to in 1-2-
 9 217.5(1)(b)(I) and (II) or elsewhere in statute, where not specifically stated, must be
 10 current and valid.
 11 30.12 Pursuant to 1-1-104(19.5)(a), if the ID that requires a photograph does not contain a
 12 photograph, it is not an acceptable ID for registration by mail or voting purposes.
 13 30.13 Identification for Voting in Person
 14 30.13.1 Voting in Person. (Including early voting, polling place voting).
 15 (A) The acceptable forms of ID for voting in person are listed in Rule 2.3(a);
 16 ~~• A valid Colorado driver’s license;~~
 17 ~~• A valid identification card issued by the Department of Revenue IN~~
 18 ~~ACCORDANCE WITH THE REQUIREMENTS OF PART 3 OF ARTICLE 2 OF~~
 19 ~~TITLE 42, C.R.S.;~~
 20 ~~• A valid U.S. passport;~~
 21 ~~• A valid employee identification card with a photograph of the~~
 22 ~~eligible elector issued by any branch, department, agency, or entity~~
 23 ~~of the United States government or of this state, or by any county,~~
 24 ~~municipality, board, authority, or other political subdivision of this~~
 25 ~~state;~~
 26 ~~• A valid pilot’s license issued by the federal aviation administration~~
 27 ~~or other authorized agency of the United States;~~
 28 ~~• A valid U.S. military identification card with a photograph OF THE~~
 29 ~~ELIGIBLE ELECTOR;~~
 30 ~~• A copy of a current utility bill, bank statement, government check,~~
 31 ~~paycheck, or other government document that shows the name and~~
 32 ~~address of the elector (A cable bill, a telephone bill, documentation~~
 33 ~~from a public institution of higher education in Colorado~~
 34 ~~containing at least the name, date of birth, and LEGAL residence~~
 35 ~~address of the student elector, or a paycheck from a government~~
 36 ~~institution are sufficient forms of ID);~~
 37 ~~• A valid Medicare or Medicaid card ISSUED BY THE UNITED STATES~~
 38 ~~HEALTH CARE FINANCING ADMINISTRATION;~~
 39 ~~• A certified copy of a U.S. birth certificate FOR THE ELECTOR ISSUED~~
 40 ~~IN THE UNITED STATES; or~~
 41 ~~• Certified documentation of naturalization.~~
 42 (B) A Social Security Number (or last four digits) is NOT a legal form of ID
 43 for voting in person.
 44 Authority: 1-7-201 C.R.S.; 1-1-104(19.5) C.R.S.

Formatted

1 30.13.2 When the elector shows ID pursuant to 1-1-104(19.5), the election judge
2 shall check to ensure that the name matches, and that the address, if one is listed,
3 is in the State of Colorado.

4 30.14 Identification for Voting by Mail

5 30.14.1 Voting By Mail (Including Absentee)

6 (a) The acceptable forms of ID for voting by mail for first time voters are
7 listed in Rule 2.3(a):

- 8 ~~• A valid Colorado driver's license;~~
- 9 ~~• A valid identification card issued by the department of revenue IN~~
10 ~~ACCORDANCE WITH THE REQUIREMENTS OF PART 3 OF ARTICLE 2 OF~~
11 ~~TITLE 42, C.R.S.;~~
- 12 ~~• A valid U.S. passport;~~
- 13 ~~• A valid employee identification card with a photograph of the~~
14 ~~eligible elector issued by any branch, department, agency, or entity~~
15 ~~of the United States government or of this state, or by any county,~~
16 ~~municipality, board, authority, or other political subdivision of this~~
17 ~~state;~~
- 18 ~~• A valid pilot's license issued by the federal aviation administration~~
19 ~~or other authorized agency of the United States;~~
- 20 ~~• A valid U.S. military identification card with a photograph OF THE~~
21 ~~ELIGIBLE ELECTOR;~~
- 22 ~~• A copy of a current utility bill, bank statement, government check,~~
23 ~~paycheck, or other government document that shows the name and~~
24 ~~address of the elector (A cable bill, a telephone bill, documentation~~
25 ~~from a public institution of higher education in Colorado~~
26 ~~containing at least the name, date of birth, and LEGAL residence~~
27 ~~address of the student elector, or a paycheck from a government~~
28 ~~institution are sufficient forms of ID);~~
- 29 ~~• A valid Medicare or Medicaid card ISSUED BY THE UNITED STATES~~
30 ~~HEALTH CARE FINANCING ADMINISTRATION;~~
- 31 ~~• A certified copy of a U.S. birth certificate FOR THE ELECTOR ISSUED~~
32 ~~IN THE UNITED STATES; or~~
- 33 ~~• Certified documentation of naturalization.~~

34 (b) A Social Security Number (or last four digits) is NOT a legal form of ID
35 for voting by mail.

36 30.15 Identification presented by the elector when registering to vote by mail, or presented by
37 the elector when returning the voted mail ballot or absentee ballot, is not required to be
38 scanned or imaged into the permanent voter registration database, but shall be retained by
39 the designated election official for a period of 25 months after the date of the election.

40 30.16 IF A VOTER HAS BEEN DIRECTED TO RETURN IDENTIFICATION WITH HIS OR HER VOTED
41 BALLOT, THE ELECTION JUDGE SHALL OPEN THE RETURNED ENVELOPE TO RETRIEVE THE
42 REQUIRED INFORMATION. IF THE REQUIRED INFORMATION CANNOT BE FOUND IN THE
43 RETURN ENVELOPE, THE ELECTION JUDGE SHALL OPEN THE SECRECY ENVELOPE/SLEEVE TO
44 FIND THE REQUIRED IDENTIFICATION IN AN EFFORT TO NOT DISENFRANCHISE THE VOTER.

45 30.17 If a tagged voter requests an absentee ballot, the local election official shall send such
46 ballot with written instructions advising the voter of the requisite forms of identification

Formatted

1 needed to be provided with the absentee ballot. The local election official shall send the
2 absentee ballot by the deadline set forth in 1-8-104(3) C.R.S. If an absentee ballot is
3 returned without ID as defined in Rule 2.0, then the ballot shall be treated as a provisional
4 ballot and verified pursuant to Rule 26.9.

5 **Rule 31. Rules Concerning Help America Vote Act, Title III: Administrative**
6 **Complaint Procedures**

7 31.1 The HAVA Title III complaint may be received by the Secretary of State's office or the
8 designated election official's office. The HAVA Complaint procedure shall be uniform
9 and nondiscriminatory. The Complaint procedure shall conform to 1-1.5-105(2)(a) C.R.S.
10 as follows:

- 11 (a) A uniform and nondiscriminatory complaint procedure;
- 12 (b) Authorization for any person who has either been personally aggrieved by
13 or has personally witnessed a violation of title III of HAVA that has
14 occurred, is occurring, or that is about to occur, as applicable, to file a
15 complaint;
- 16 (c) A description by the complainant in his or her complaint of the alleged
17 violation with particularity and a reference to the section of HAVA
18 alleged to have been violated;
- 19 (d) A requirement that the complaint be filed no later than one year from the
20 date of either the occurrence of the alleged violation or of the election
21 giving rise to the complaint, whichever is later;
- 22 (e) A requirement that each complaint be in writing and notarized, signed, and
23 sworn by the person filing the complaint;
- 24 (f) Authorization for the secretary to consolidate two or more complaints;
- 25 (g) At the request of the complainant, a hearing on the record;
- 26 (h) Authorization for the secretary to provide an appropriate remedy if the
27 secretary determines that any provision of title III of HAVA has been
28 violated or to dismiss the complaint and publish the results of his or her
29 review if the secretary determines that no provision of title III of HAVA
30 has been violated.
- 31 (i) A final determination on the complaint by the secretary prior to the
32 expiration of the ninety-day period that begins on the date the complaint is
33 filed, unless the complainant consents to an extension of time for making
34 such determination;
- 35 (j) Resolution of the complaint within sixty days under an alternative dispute
36 resolution procedure that the secretary shall establish in accordance with
37 the requirements of this section if the secretary fails to satisfy the
38 applicable deadline specified in 1-1.5-105(2)(i) C.R.S., and the availability
39 of the record and any other materials from any proceedings conducted
40 under the complaint procedures established for use under such alternative
41 dispute resolution procedures;
- 42 (k) Authorization for the secretary to conduct a preliminary review of any
43 complaint submitted to him or her and to dismiss any complaint that he or
44 she finds is not supported by credible evidence; and
- 45 (l) Recovery by the secretary of the costs of the proceeding against any
46 complainant who files a complaint that, in connection with the final

1 determination by the secretary of the costs of the proceeding against any
2 complainant who files a complaint that, in connection with the final
3 determination by the secretary pursuant to 1-1.5-105(2)(i), is found on the
4 basis of clear and convincing evidence to be frivolous, groundless, or
5 vexatious.

- 6 31.2 The complaint must be in writing and may be submitted on a form designated by the
7 Secretary of State or in a letter written by the complainant. The letter shall contain the
8 following:
- 9 (a) The complainant's name;
 - 10 (b) The complainant's full residence address, including county, and mailing
11 address (if different from residence);
 - 12 (c) A description of the alleged violation with particularity and a reference to
13 the section of Title III of HAVA alleged to have been violated;
 - 14 (d) A completed, notarized oath signed by the complainant where he or she
15 states that the facts of the complaint are true and correct to the best of his
16 or her knowledge and belief.
- 17 31.3 Whenever possible, any completed complaints mailed to the Secretary of State or the
18 designated election official shall be sent in a unique, distinguishable envelope as
19 approved by the Secretary of State. This unique envelope shall be given to the
20 complainant at the same time as the complaint form and instructions.
- 21 31.4 Upon receipt of the HAVA complaint, the Secretary of State or designated election
22 official shall note the date received and unique tracking number on the complaint form.
23 The Secretary of State's office shall establish a unique tracking number for its use, and
24 the designated election official shall use the Secretary of State's county ID number for
25 that county, the last two digits of the present year, and a sequence number according to
26 the amount of complaints already received by the county, placing hyphens between
27 groupings of numbers. (For example, the first one received would be the two digit
28 county number-last two digits of the year-03 with 01, 02, 03, etc. numbering any
29 sequential complaints).
- 30 31.5 If the complaint is received by the Secretary of State's office, the unique tracking number
31 shall be added to the form and the form shall be faxed to the designated election official
32 in the county where the alleged violation occurred. The complainant shall receive a copy
33 of the submitted complaint with all check-in notations and tracking numbers included.
- 34 31.6 If the complaint is received by the designated election official, the county tracking
35 number shall be added to the form and the form shall be faxed to the Secretary of State's
36 office within one business day. The complainant shall receive a copy of the submitted
37 complaint with all check-in notations and tracking numbers included. The original
38 complaint form shall be hand delivered or mailed to the Secretary of State's office, and a
39 copy shall be retained by the designated election official.
- 40 31.7 Any original mailed complaints sent by the designated election official and received by
41 the Secretary of State's office shall be sent in a unique, distinguishable mailing envelope
42 as approved by the Secretary of State. This unique envelope will ensure that the
43 complaint is easily recognizable and will be processed in a timely manner.
- 44 31.8 If the complaint is received by the designated election official and the original sent to the
45 Secretary of State's office, the Secretary of State's office shall notify the designated
46 election official, either by fax or letter, of the office's unique tracking number when the

- 1 form is received at the Secretary of State's office. This official notification may be used
2 for documentation purposes.
- 3 31.9 The designated election official shall not make any determination as to the validity of the
4 alleged complaint during the submission process, but shall forward all information to the
5 Secretary of State's office. The county may, however, begin researching the alleged
6 violation on the local level once the complaint is received.
- 7 31.10 Any information gathered by the designated election official shall be documented with
8 specific details, including the date, and shall be used for reference purposes.
- 9 **Rule 32. Rules Concerning Recall**
- 10 32.1 In any recall election of a partisan office, the successor nominee's party affiliation shall
11 be listed with his or her name on the ballot.
- 12 **32.2.1 FOR PETITIONS TO RECALL SCHOOL DISTRICT DIRECTORS THE PETITION MUST
13 BE SIGNED BY THE ELIGIBLE ELECTORS OF THE SCHOOL DISTRICT EQUAL IN
14 NUMBER TO AT LEAST 40% OF THE BALLOTS CAST IN THE DISTRICT IN THE LAST
15 PRECEDING ELECTION AT WHICH THE DIRECTOR TO BE RECALLED WAS
16 ELECTED AS INDICATED BY THE POLLBOOK OR ABSTRACT FOR THE ELECTION.
17 SEE 1-12-105 C.R.S.**
- 18 32.2 Petition sufficiency occurs when upon review, it is established that the petition contains
19 the required number of valid signatures.
- 20 32.3 When a protest is filed, petition sufficiency is sustained upon conclusion of the protest
21 when the designated election official or the district judge maintains that there are
22 sufficient valid signatures.
- 23 **32.4 WHEN AN OFFICER SUBJECT TO BEING RECALLED RESIGNS WITHIN THE FIVE DAYS
24 AFTER THE SUFFICIENCY OF THE RECALL PETITION HAS BEEN SUSTAINED, THE RECALL
25 ELECTION DOES NOT GO FORWARD, AND THE POSITION IS DECLARED VACANT AND
26 FILLED ACCORDING TO STATUTE.**
- 27 **Rule 33. Rules Concerning Voters Who Vote After the Polls Close Pursuant to a
28 Court Order**
- 29 33.1 Any individual who votes in an election for federal office as a result of a federal or state
30 court order or any other order that is in effect 10 days before that election and which
31 extends the time established for closing the polls by state law may only vote in that
32 election by casting a provisional ballot pursuant to state law and the rules and regulations
33 prescribed by the Secretary of State.
- 34 33.1.1 Any such provisional ballot cast under this rule shall be separated and held apart
35 from other provisional ballots cast by those voters not affected by the court order.
- 36 **Rule 34. Rules Concerning the Adoption of Accessible Voting Systems under The
37 Help America Vote Act of 2002.**
- 38 34.1 The requirements of §301(a)(3) of The Help America Vote Act of 2002 ("HAVA") to
39 implement voting systems that: (1) are accessible for individuals with disabilities,
40 including nonvisual accessibility for the blind and visually impaired, in a manner that
41 provides the same opportunity for access and participation (including privacy and
42 independence) as for other voters and (2) provide alternative language accessibility
43 pursuant to the requirements of section 203 of the Voting Rights Act of 1965 (42 U.S.C.
44 1973aa-1a) are triggered when a political subdivision acquires a new voting system by
45 lease or purchase using HAVA §301(a)(3) funds after January 1, 2003.

- 1 34.2 No political subdivision shall purchase or lease direct recording electronic (DRE) voting
2 systems or other voting systems equipped for individuals with disabilities at each polling
3 place unless such voting system(s) are fully certified pursuant to standards and guidelines
4 recommended by the National Institute of Standards and Testing (NIST) and adopted by
5 the U.S. Election Assistance Commission (EAC).
- 6 34.3 The Secretary of State, as custodian of §301(a)(3) of HAVA funds, will not distribute
7 such funds to any political subdivision to pay for accessible voting systems that have not
8 been fully certified by the EAC and the Secretary of State.
- 9 34.4 Only the acquisition of a new voting system (or substantial modification of an existing
10 voting system) that will change voters' interaction with the ballot at the polling sites
11 triggers §301(a)(3) of HAVA.
- 12 34.5 If a political subdivision acquires a new voting system, the system must be accessible to
13 persons with physical, cultural/educational, mental/cognitive disabilities and provide the
14 voter in a manner that provides the same opportunity for access and participation
15 (including privacy and independence) as for other voters.
- 16 34.6 The Help America Vote Act requires that a newly acquired voting system be placed in
17 every early voting and Election Day polling site by January 1, 2006.

18 **Rule 35. Rules Concerning Requirements for Voting System Accessibility**
19 35.1

- 20 (A) A voting system shall be accessible to voters with physical disabilities
21 including no vision, low vision (visual acuity between 20/70 and 20/200,
22 and/or 30 degree or greater visual-field loss), no hearing, low hearing,
23 limited manual dexterity, limited reach, limited strength, no mobility, low
24 mobility, or any combination of the foregoing by providing voters with
25 physical disabilities with a practical and effective means to cast an
26 independent and secret ballot in accordance with each of the following,
27 assessed independently and collectively:
- 28 (1) The voting system shall provide a tactile-input or speech-input
29 device, or both; and
 - 30 (2) The voting system shall provide a method by which voters can
31 confirm any tactile or audio input by having the capability of audio
32 output using synthetic or recorded human speech, which is
33 reasonably phonetically accurate; and
 - 34 (3) The voting system shall provide a means for a voter to change the
35 voter's selection prior to the voter casting the ballot; and
 - 36 (4) Any operable controls on the input device that are needed for
37 voters without vision shall be discernable tactilely without
38 actuating the keys. As a result, all the buttons on the device do not
39 have to be discernable tactilely, only those buttons that are actually
40 required for the individual to use the "operation without vision"
41 mode; and
 - 42 (5) Any audio and non-audio access approaches shall be able to work
43 both separately and simultaneously; and
 - 44 (6) If a non-audio access approach is provided, the system shall not
45 require color perception; the system shall use black text or
46 graphics, or both, on white background or white text or graphics,

1 or both, on black background, unless the office of the Secretary of
2 State approves other high-contrast color combinations that do not
3 require color perception; and

- 4 (7) Any voting system that requires any visual perception shall offer
5 the election official who programs the system, prior to its being
6 sent to the polling place, the capability to set the font size to a level
7 that can be read by voters with low vision. While there is no
8 standard font size for this situation, a san-serif font of 18 points as
9 printed on a standard 8.5" x 11" piece of paper will allow the most
10 universal access; and
- 11 (8) The voting system shall provide audio information, including any
12 audio output using synthetic or recorded human speech or any
13 auditory feedback tones that are important for the use of the audio
14 approach, through at least one mode (e.g., by handset or headset)
15 in enhanced auditory fashion (i.e., increased amplification), and
16 shall provide incremental volume control with output amplification
17 up to a level of at least 97 decibels Sound Pressure Level ("dB
18 SPL"), with at least one intermediate step of 89 dB SPL; and
- 19 (9) For transmitted voice signals, the voting system shall provide a
20 gain adjustable up to a minimum of 20 decibels ("dB") with at
21 least one intermediate step of 12 dB of gain; and
- 22 (10) For the safety of others, if the voting system has the possibility of
23 exceeding 120 dB SPL, then a mechanism shall be included to
24 reset the volume automatically to a safe level after every use (e.g.,
25 when handset is replaced) but not before; and
- 26 (11) If sound cues and audible information, such as "beeps" are used,
27 there shall be simultaneous corresponding visual cues and
28 information; and
- 29 (12) If a non-audio approach is used in conjunction with an audio
30 counterpart, any spoken text shall also be presented on screen. A
31 graphic representation of a ballot with a check, "X," etc. beside a
32 candidate or proposition is allowed; and
- 33 (13) All controls and operable mechanisms shall be operable with one
34 hand, including with a closed fist, and operable without tight
35 grasping, pinching, or twisting of the wrist; and
- 36 (14) The force required to operate or activate the controls shall be no
37 greater than 5 pounds per square foot ("lb./sq.ft."); and
- 38 (15) If a forward approach by a person in a wheelchair to a voting
39 system is necessary, the maximum high-forward reach allowed
40 shall be 48 inches (1220 mm) and the minimum low-forward reach
41 shall be 15 inches (380 mm). If the high-forward reach is over an
42 obstruction, reach and clearances shall be as shown in the **Figure**
43 **1.**, or otherwise in accordance with the Americans with Disabilities
44 Act Accessibility Guidelines for Buildings and Facilities
45 ("ADAAG"), as written at the time the system is certified for use
46 in the state of Colorado; and

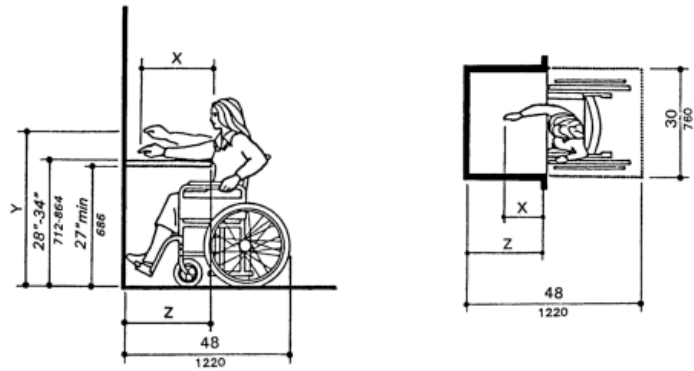

NOTE: x shall be ≤ 25 in(635 mm); z shall be $\geq x$. When $x < 20$ in(510 mm), then y shall be 48 in(1220 mm) maximum. When x is 20 to 25 in(510 to 635 mm), then y shall be 44 in(1120 mm) maximum.

Figure 1.

Figure 1.

[1505_1_35.1_15.jpg](#)

- (16) If a side or parallel approach by a person in a wheelchair to a voting system is necessary, the maximum side reach allowed shall be 54 inches (1370 mm) and the low side reach shall be no less than 9 inches (230 mm) above the floor. If the side reach is over an obstruction, reach and clearances shall be as shown in the **Figure 2.**, or otherwise in accordance with the ADAAG, as written at the time the system is certified for use in the state of Colorado; and

Figure 2.

[1505_1_35.1_16.jpg](#)

Figure 2.

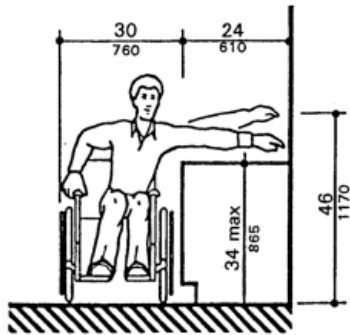

1
2
3
4
5
6
7
8
9
10
11
12
13
14
15
16
17
18

1 (17) The highest operable part of controls, dispensers, receptacles, and
2 other operable equipment shall be placed within at least one of the reach
3 ranges outlined in paragraphs (15) and (16) of this subsection.

4 **Rule 36. Rules Concerning Notice of Voting System Malfunction Required;**
5 **Submission of Explanatory Report by Vendor Required Upon Request of Secretary**
6 **of State**

- 7 36.1 A vendor (or the political subdivision, if no private vendor supports their system) must
8 give notice to the Secretary of State within 24 hours of a malfunction of its
9 voting/election system (including, but not limited to, software, firmware, hardware, or
10 other equipment) in preparation for and on an election held in this state. The notice may
11 be verbal, but must also be in writing.
- 12 36.2 Following the notice, the Secretary of State shall determine whether further information
13 on the malfunction is required. At the request of the Secretary of State, a vendor (or the
14 political subdivision, if no private vendor supports their system) must submit a report to
15 the Secretary of State's office detailing the reprogramming (or any other actions)
16 necessary to **CORRECT** a voting system malfunction in preparation for and on an election
17 held using the vendor's system. The report shall address whether permanent changes are
18 necessary to prevent similar malfunctions in the future. **IF THE MALFUNCTION REQUIRES**
19 **A PROGRAMMING OR ELECTION SETUP CHANGE TO THE DATABASE OR OTHER PARTS OF**
20 **THE VOTING SYSTEM, THE DESIGNATED ELECTION OFFICIAL SHALL SUBMIT AN**
21 **UPDATED ELECTRONIC COPY OF THE ELECTION SYSTEM DATABASE TO THE SECRETARY**
22 **OF STATE'S OFFICE AS SET FORTH IN RULE 11.**
- 23 36.3 The report shall be submitted within 30 days after the date of the request by the Secretary
24 of State. Notwithstanding the foregoing, if an election is scheduled within 60 days of the
25 date of request by the Secretary of State, the Secretary of State may set an emergency
26 deadline for filing the report. The request may be **VERBAL**, but must also be in writing.
- 27 36.4 Failure to submit a report within the required period shall be grounds to decertify the
28 system.
- 29 36.5 The political subdivision holding the election in which the voting system malfunction
30 occurred may submit the report in lieu of a report from the system's vendor.
- 31 36.6 A copy of this report will be attached to the system's most recent certification on file in
32 the Secretary of State's office.
- 33 36.7 The Secretary of State's office will distribute a copy of this report to all counties using the
34 voting system in question.

35 **Rule 37. The Acquisition, Purchase or Lease of Voting Systems.**

- 36 37.1 Declaration of Intent.
- 37 37.1.1 The federal Help America Vote Act of 2002 ("HAVA") established uniform
38 voting systems standards used in elections . **THE FOLLOWING RULES SEEK TO**
39 **CONFORM COLORADO REQUIREMENTS TO FEDERAL HAVA REQUIREMENTS**
40 **PERTAINING TO VOTING SYSTEMS.**
- 41 37.1.2 Voting systems (including optical scanning voting systems or direct recording
42 electronic systems) certified by the secretary of state and acquired, purchased or
43 leased by counties pursuant to state law shall:
- 44 (a) permit the voter to verify (in a private and independent manner) the votes
45 selected by the voter on the ballot before the ballot is cast and counted;

- 1 (b) provide the voter with the opportunity (in a private and independent
2 manner) to change the ballot or correct any error before the ballot is cast
3 and counted (including the opportunity to correct the error through the
4 issuance of a replacement ballot if the voter was otherwise unable to
5 change the ballot or correct any error); and
6 (c) if the voter selects votes for more than one candidate for a single office:
7 (i) notify the voter that the voter has selected more than 1 candidate
8 for a single office on the ballot;
9 (ii) notify the voter before the ballot is cast and counted of the effect of
10 casting multiple votes for the office; and
11 (iii) provide the voter with the opportunity to correct the ballot before
12 the ballot is cast and counted.
13 (D) **ENSURE THAT ANY NOTIFICATION REQUIRED UNDER THIS PARAGRAPH
14 PRESERVES THE PRIVACY OF THE VOTE AND THE CONFIDENTIALITY OF
15 THE BALLOT.**

- 16 37.1.3 Counties of the State of Colorado that use a paper ballot voting system or a
17 central count voting system (including mail-in absentee ballots and mail-in
18 ballots), may meet the requirements of **THIS RULE** by:
19 (a) establishing a voter education program specific to that voting system that
20 notifies each voter of the effect of casting multiple votes for an office; and
21 (b) providing the voter with instructions on how to correct the ballot before it
22 is cast and counted (including instructions on how to correct the error
23 through the issuance of a replacement ballot if the voter was otherwise
24 unable to change the ballot or correct any errors).

25 *Note: This rule has been incorporated into 37.1.2 above.*

- 26 37.1.4 The voting systems described in the foregoing paragraphs shall produce a record
27 with an audit capacity for such system.
28 (a) The voting system shall produce a permanent paper record with a manual
29 audit capacity for such system.
30 (b) The voting system shall provide the voter with an opportunity to change
31 the ballot or correct any error before the permanent paper record is
32 produced.
33 (c) The paper record produced under subparagraph (A) shall be available as an
34 official record for any recount conducted with respect to any election in
35 which the system is used.
36 (D) **THE PAPER RECORD SHALL BE ACCESSIBLE FOR INDIVIDUALS WITH
37 DISABILITIES INCLUDING NONVISUAL ACCESSIBILITY FOR THE BLIND AND
38 VISUALLY IMPAIRED, IN A MANNER THAT PROVIDES THE SAME
39 OPPORTUNITY FOR ACCESS AND PARTICIPATION (INCLUDING PRIVACY
40 AND INDEPENDENCE) AS FOR OTHER VOTERS.**

- 41 37.1.5 The voting system shall:
42 (a) be accessible for individuals with disabilities, including nonvisual
43 accessibility for the blind and visually impaired, in a manner that provides
44 the same opportunity for access and participation (including privacy and
45 independence) as for other voters;

- 1 (b) satisfy the requirements of paragraph 37.1.5(a) through the use of at least
2 one direct recording electronic voting system or other voting system
3 equipped for individuals with disabilities at each polling place; and
4 (c) shall be installed in each polling place in the state by January 1, 2006.
- 5 37.1.6 The voting system shall provide alternative language accessibility pursuant to the
6 requirements of section 203 of the Voting Rights Act of 1965.
- 7 37.2 Prohibition of lease, purchase, or acquisition of voting systems pending action by the
8 Election Assistance Commission (EAC) **AND CERTIFICATION THROUGH THE**
9 **SECRETARY OF STATE..**
- 10 37.2.1 No voting system may be leased, purchased, or acquired by any county or
11 political subdivision of this state until the EAC **AND THE SECRETARY OF STATE**
12 **HAVE** promulgated voting systems standards that address these concerns. This
13 rule shall not apply to voting systems that have been certified by the Secretary of
14 State and purchased by the political subdivisions pursuant to state law prior to the
15 effective date of this rule.
- 16 37.3 Adoption of April 30, 2002 Voting Systems Standards promulgated by the Federal
17 Election Commission for voting systems.
- 18 37.3.1 The Secretary of State hereby adopts the April 30, 2002 Voting Systems
19 Standards promulgated by the Federal Election Commission for voting systems.
20 Therefore, **ALL** voting systems, including, but not limited to, optical scan voting
21 systems, **DIRECT RECORD ELECTRONIC VOTING SYSTEMS, AND TOUCH SCREENS,**
22 purchased by the political subdivisions of the State of Colorado are required to
23 meet the qualifications of the Voting Systems Standards promulgated by the
24 Federal Election Commission on April 30, 2002 and be certified by an
25 independent testing authority certified by the National Association of Election
26 Directors until such time, and subsequently thereto, at each time, as the Election
27 Assistance Commission promulgates new Voting Systems Standards.
- 28 37.3.2 Upon any revision or new release of Voting Systems Standards by the Election
29 Assistance Commission, the Secretary of State hereby automatically adopts such
30 standards as may be promulgated, and any vendor seeking state certification shall
31 follow such adopted voting systems standards and the processes mandated by
32 state law in order to be certified by the Secretary of State.
- 33 **37.4 THE SECRETARY OF STATE REQUIRES ALL VOTING SYSTEMS AND ALL INDIVIDUAL**
34 **PARTS OF VOTING SYSTEMS TO PASS CERTIFICATION CRITERIA AS OUTLINED IN THE**
35 **STATE OF COLORADO VOTING SYSTEMS CERTIFICATION PROGRAM. THE DESIGNATED**
36 **ELECTION OFFICIAL SHALL RETAIN RECORDS OF ALL CERTIFICATION PROCEDURES**
37 **PERTAINING TO VOTING SYSTEMS AND PARTS OF VOTING SYSTEMS.**
- 38 **Rule 38. Minimum Security Procedures for Transmission of Election Records by**
39 **Secure, Dedicated Teleprocessing Lines Employed by Vote Centers. See 1-5-102.7**
40 **C.R.S.**
- 41 38.1 Definitions.
- 42 38.1.1 "Vote Center" means a polling place at which any registered elector in the
43 political subdivision holding the election may vote, regardless of the precinct in
44 which the elector resides.
- 45 38.1.2 "Teleprocessing Lines" means secure, dedicated communication transmission
46 facilities used for the purpose of transferring Elector Data between Vote Centers

1 and a centralized computerized pollbook maintained by the County Clerk and
2 Recorder, to ensure the security and integrity of voting information so that no
3 deviation can go undetected.

4 38.1.3 "Elector Data" means voting information, including but not limited to, voter
5 registration, voting history, and voting tabulations.

6 38.1.4 "Electronic Pollbook" is a list of eligible electors in electronic format who are
7 permitted to vote at a polling place in an election conducted under the Election
8 Code, which shall be processed by a computer at a Vote Center to be immediately
9 accessible to all other computers at all Vote Centers in the county.

10 38.2 This Rule applies to each designated election official who transmits election records via
11 Teleprocessing Lines to a centralized Electronic Pollbook maintained by the county clerk
12 and recorder for the purpose of running an election and compiling complete returns.

13 38.3 The designated election official shall establish written minimum security procedures
14 covering the transference of Vote Center teleprocessing information. Such procedures
15 shall include security covering the transmission of Elector Data processed through the
16 Electronic Pollbook and reconciliation of the registration and history of voters casting
17 ballots at a Vote Center.

18 38.4 Such procedures shall be submitted in writing to the Secretary of State and received by
19 that Office for approval no later than sixty (60) days before the election date. The
20 Secretary of State shall either approve the procedures submitted or notify the designated
21 election official of recommended changes.

22 38.5 If the Secretary of State rejects or approves the written procedures, the Secretary of State
23 shall provide written notice of such rejection/approval, including specifics of non-
24 compliance with this Rule, within fifteen (15) days of receiving the written procedures.

25 38.6 The designated election official shall submit a revised procedure within fifteen (15) days
26 thereafter.

27 38.7 The Secretary of State shall permit the filing of the revised procedures at a later date if it
28 is determined that compliance with the fifteen day requirement is impossible.

29 38.8 All reconciliations must be accomplished prior to canvassing board certification of final
30 results and shall be certified by the canvassing board. The certification of reconciliation
31 shall be filed with the Secretary of State at the time the canvassing board certification of
32 official election results is filed.

33 38.9 Where the Elector Data is transmitted via Teleprocessing Lines for the purpose of
34 combining with other such tabulations to produce complete returns, the designated
35 election official shall establish procedures to reconcile received transmitted tabulations so
36 that no deviation can go undetected.

37 38.10 Prior to January 1, 2006, election judges shall make one certificate for each Vote Center
38 in the form required by 1-7-601 C.R.S.

39 38.11

40 (a) In addition to the statutory form required by 1-7-601 C.R.S., the election
41 judges for each Voter Center shall submit a certification of reconciliation
42 in substantially the following form:
43 During the ____ Election held in ____ County on _____
44 20____, Elector Data was transmitted using dedicated Teleprocessing Lines. The
45 canvassing board hereby certifies that the reconciliation procedures required by

1 Rule 38.8, Minimum Security Procedures for Transmission of Election Records
2 by Dedicated Teleprocessing Lines in Vote Centers has been complied with.

3 (b) The Certification of Reconciliation must be signed and dated by the
4 designated election official.

5 38.12 After January 1, 2006, reconciliation shall consist of race-by-race comparison by precinct
6 of the received tabulation to a tabulation report produced from the original tabulations
7 sent from the precinct to those received at the Vote Center. All tabulation reconciliations
8 must be accomplished prior to canvassing board certification of final results and shall be
9 certified by the canvassing board. This certification of reconciliation shall be filed with
10 the Secretary of State at the time of the canvassing board certification of official election
11 results is filed.
12

13 **RULE 39. CANCELLATION OF FELONS' VOTER REGISTRATIONS**

14 39.1 UPON BEING PROVIDED INFORMATION CONCERNING FELONY CONVICTIONS AND PURSUANT
15 TO C.R.S. 1-2-302(3.5)(B), THE SECRETARY OF STATE SHALL DIRECT THE CANCELLATION
16 OF THE REGISTRATION OF PERSONS CONVICTED OF A FELONY WHO ARE SERVING A
17 SENTENCE OF CONFINEMENT OR DETENTION OR ARE ON PAROLE.

18 **39.1.1 THIS RULE DOES NOT PERTAIN TO A FELON SERVING A PERIOD OF PROBATION.**

19 39.2 THE SECRETARY OF STATE SHALL COMPARE THE FELONY CONVICTION DATA WITH THE
20 SECRETARY OF STATE'S VOTER REGISTRATION DATABASE TO MATCH VOTER REGISTRATION
21 INFORMATION WITH THE INDIVIDUALS LISTED USING THE FOLLOWING CRITERIA:

- 22 (1) THE LAST NAME AND FIRST NAME OF EACH INDIVIDUAL,
23 (2) THE DATE OF BIRTH,
24 (3) THE SOCIAL SECURITY NUMBER OR LAST FOUR DIGITS (IF PROVIDED).

25 39.2.1 ANY CONFIRMED MATCH OF THE LAST NAME AND FIRST NAME OF THE INDIVIDUAL
26 AND EITHER THE DATE OF BIRTH OR THE SOCIAL SECURITY NUMBER, OR AT LEAST
27 THE LAST FOUR DIGITS, WILL BE CONSIDERED ADEQUATE CANCELLATION CRITERIA.

28 39.2.2 THE COUNTY CLERK AND RECORDER SHALL SEND WRITTEN NOTICE TO ALL
29 INDIVIDUALS CANCELLED PURSUANT TO THIS RULE ADVISING THE INDIVIDUAL THAT
30 HIS OR HER VOTER REGISTRATION HAS BEEN CANCELLED. THE FELON NOTIFICATION
31 OF CANCELLATION LETTERS SHALL BE IN A FORMAT APPROVED BY THE SECRETARY
32 OF STATE, AND SHALL BE MAILED TO THE LAST KNOWN MAILING ADDRESS AS
33 SHOWN ON THE CLERK AND RECORDER'S RECORDS.

34 39.3 FOR ANY CONFIRMED MATCHES OF CONVICTED FELONS FOUND PURSUANT TO RULE 39.2,
35 SUCH MATCHES SHALL BE **PROVIDED** TO THE COUNTY CLERK AND RECORDER OF THE
36 COUNTY OF RESIDENCE OF THE INDIVIDUAL AS RECORDED IN THE SECRETARY OF STATE
37 VOTER REGISTRATION DATABASE TO BE CANCELLED PURSUANT TO 1-2-302(3.5)(B) AND 1-
38 2-103(4) C.R.S.

39 39.4 EACH COUNTY CLERK SHALL SOLICIT A LISTING OF INDIVIDUALS CONVICTED OF A FELONY
40 FROM THE COUNTY SHERIFF OF THEIR RESPECTIVE COUNTIES.

41 39.4.1 SUCH LISTS SHALL BE OBTAINED AT LEAST ONCE A MONTH **THROUGHOUT THE**
42 **YEAR. DURING ANY MONTH IN WHICH AN ELECTION OCCURS, SUCH LISTS**
43 **SHALL BE OBTAINED UP TO AND INCLUDING THE DAY PRIOR TO THE ELECTION.**

44 39.4.2 **THE REGISTRATIONS OF** CONFIRMED MATCHES OF INDIVIDUALS ON THE LISTS
45 FURNISHED BY THE COUNTY SHERIFFS SHALL BE CANCELLED UNDER THE CRITERIA
46 SET FORTH IN RULE 39.2.

1 **RULE 40. RULES CONCERNING CERTIFICATION AND EDUCATION OF DESIGNATED**
2 **ELECTION OFFICIALS**

3 40.1 PURPOSE:

4 40.1.1 THE PURPOSE OF THE CERTIFICATION PROGRAM IS TO RECOGNIZE THAT THE
5 OVERSEEING OF ELECTIONS IS A PROFESSION REQUIRING A THOROUGH KNOWLEDGE
6 OF STATE AND FEDERAL ELECTION LAW AND ELECTION PROCEDURES. IT IS
7 RECOGNIZED THAT STATE AND FEDERAL LAW, VOTING EQUIPMENT AND ELECTION
8 PROCEDURES ARE INCREASINGLY MORE COMPLEX AND NECESSITATE EXTENSIVE
9 TRAINING. IT IS ALSO RECOGNIZED THAT COLORADO AIMS TO STANDARDIZE
10 ELECTION PROCEDURES AND EDUCATION. THE ULTIMATE PURPOSE OF RULE 40 IS TO
11 ASSURE THAT COLORADO VOTERS HAVE A GREATER CONFIDENCE IN THEIR
12 ELECTION OFFICIALS AND THE ELECTION PROCESS.

13 40.2 ADVISORY BOARD CREATED

14 40.2.1 THE SECRETARY OF STATE SHALL CREATE AN ADVISORY BOARD TO OVERSEE THE
15 CERTIFICATION PROGRAM AND CURRICULUM. THE BOARD SHALL MEET AT LEAST
16 TWICE EACH CALENDAR YEAR TO APPROVE THE CURRICULUM AND MAKE
17 NECESSARY CHANGES. IT SHALL ALSO REVIEW EVALUATIONS AND RECOMMEND
18 CHANGES TO THE CERTIFICATION PROGRAM.

19 40.2.2 THE ADVISORY BOARD SHALL REVIEW INDIVIDUAL APPLICATIONS FOR
20 CERTIFICATION AND APPROVE APPLICATIONS THAT ARE ACCURATE AND COMPLETE.
21 THE ADVISORY BOARD HAS THE AUTHORITY TO TAKE INTO ACCOUNT SPECIAL
22 CIRCUMSTANCES REGARDING CERTIFICATION AND APPROVED CURRICULUM.

23 40.2.3 THE ADVISORY BOARD SHALL INCLUDE THE FOLLOWING MEMBERS APPOINTED BY
24 THE SECRETARY OF STATE:

25 (A) FOUR COUNTY CLERKS OR DESIGNATED STAFF MEMBERS
26 (B) TWO SECRETARY OF STATE OFFICE REPRESENTATIVES
27 (C) ANY INDIVIDUAL WHOM THE SECRETARY OF STATE BELIEVES COULD MAKE
28 A VALUABLE CONTRIBUTION TO THE BOARD.

29 40.2.4 BOARD MEMBERS SHALL BE APPOINTED BY THE SECRETARY OF STATE TO SERVE A
30 TWO-YEAR TERM. BOARD MEMBERS MAY BE TERMINATED WITHOUT CAUSE.
31 FAILURE TO ATTEND MEETINGS OR MEANINGFULLY CONTRIBUTE MAY RESULT IN
32 TERMINATION.

33 40.3 CORE CURRICULUM

34 40.3.1 THE CERTIFICATION PROGRAM SHALL INCLUDE CORE REQUIREMENTS. ALL
35 TRAINING OUTLINED HEREIN SHALL BE PROVIDED UNDER THE DIRECTION OF THE
36 SECRETARY OF STATE. PERSONS COMPLETING THE CERTIFICATION SHALL
37 COMPLETE **AT LEAST** EIGHT CORE CLASSES. THE CORE CLASSES SHALL GENERALLY
38 INCLUDE BUT ARE NOT LIMITED TO:

39 (A) THE BASIC CONDUCT OF ELECTIONS
40 (B) TESTING AND MAINTENANCE OF VOTING EQUIPMENT
41 (C) CANVASS PROCEDURES
42 (D) ABSENTEE AND PROVISIONAL VOTING
43 (E) POLLWORKER TRAINING AND RECRUITING
44 (F) SCORE TRAINING
45 (G) ETHICS
46 (H) ACCESSIBILITY FOR PEOPLE WITH DISABILITIES

1 40.3.2 THE CLASSES MAY BE OFFERED AS A WHOLE OR IN SECTIONS.
2 40.4 ELECTIVE CURRICULUM
3 THE CERTIFICATION PROGRAM SHALL INCLUDE ELECTIVES AS PART OF THE CERTIFICATION
4 PROGRAM. ALL TRAINING OUTLINED HEREIN SHALL BE PROVIDED UNDER THE
5 DIRECTION OF THE SECRETARY OF STATE. PERSONS SHALL SELECT AND COMPLETE
6 AT LEAST SIX (6) ELECTIVE COURSES. THE ELECTIVE COURSES SHALL GENERALLY
7 INCLUDE:
8 (A) VOTER OUTREACH
9 (B) MEDIA RELATIONS
10 (C) ELECTIONS REFRESHER COURSE
11 (D) PETITIONS
12 (E) OVERSEAS AND MILITARY VOTERS
13 (F) CAMPAIGN FINANCE
14 (G) SECURITY PLANNING
15 (H) ISSUES IN VOTER REGISTRATION
16 (I) POLLING PLACE SET UP/MANAGEMENT
17 (J) VOTE CENTER TRAINING
18 (K) MAIL BALLOT TRAINING
19 (L) BUDGETING
20 (M) RECOUNTS AND ELECTION CONTESTS
21 (N) OTHER TIMELY, RELEVANT TOPICS AS DETERMINED BY THE SECRETARY OF
22 STATE

23 40.5 CREDIT FOR OTHER TRAININGS. PERSONS MAY APPLY TO THE ADVISORY BOARD TO
24 REQUEST CREDIT TOWARDS COLORADO CERTIFICATION FOR TRAINING PROVIDED BY OTHER
25 NATIONAL ELECTIONS ORGANIZATIONS. THE BOARD MAY GRANT CORE OR ELECTIVE
26 HOURS FOR SUCH TRAININGS.
27

28 40.6 CONTINUING ELECTIONS EDUCATION (CEE). IN ORDER TO MAINTAIN CERTIFICATION, A
29 PERSON SHALL ATTEND AND COMPLETE AT LEAST TWO ELECTIVES OR ONE CORE CLASS
30 EVERY CALENDAR YEAR.

31 40.7 COMPLETING COLORADO CERTIFICATION

32 40.7.1 AFTER A PERSON HAS COMPLETED THE CORE REQUIREMENTS AND ELECTIVE
33 REQUIREMENTS, THE PERSON SHALL SUBMIT AN APPLICATION FOR COLORADO
34 CERTIFICATION TO THE SECRETARY OF STATE'S OFFICE.

35 40.7.2 THE SECRETARY OF STATE SHALL CREATE AN APPLICATION FORM TO BE USED BY
36 APPLICANTS FOR CERTIFICATION FOLLOWING COMPLETION OF COURSEWORK. THE
37 APPLICANTS SHALL PROVIDE THE FOLLOWING INFORMATION:
38 (A) THE APPLICANT'S NAME, NAME OF COUNTY JURISDICTION, ADDRESS,
39 TELEPHONE AND E-MAIL;
40 (B) THE APPLICANT TITLE(S) AND DATE(S) OF THE CLASSES THE APPLICANT
41 ATTENDED;
42 (C) THE APPLICANT'S SIGNATURE AND DATE SIGNED; AND
43 (D) THE SUPERVISOR'S SIGNATURE (IF APPLICABLE)

44 40.7.2.1 THE FORM SHALL ALSO INCLUDE A SECTION FOR SECRETARY OF STATE
45 OFFICE USE ONLY.

- 1 40.7.3 THE SECRETARY OF STATE SHALL REVIEW THE APPLICATION WITH REFERENCE TO
2 THE SECRETARY OF STATE RECORDS. IF THE APPLICATION IS COMPLETE AND
3 ACCURATE, THE SECRETARY OF STATE SHALL FORWARD IT TO THE ADVISORY
4 BOARD FOR THEIR APPROVAL. UPON APPROVAL BY THE ADVISORY BOARD, THE
5 SECRETARY OF STATE SHALL ISSUE A CERTIFICATE THAT THE PERSON IS A
6 CERTIFIED COLORADO ELECTION OFFICIAL.
- 7 40.7.4 THE SECRETARY OF STATE SHALL TRACK ATTENDANCE AT ALL CLASSES AND KEEP
8 RECORDS OF ATTENDANCE, CONTINUING EDUCATION, AND RECORDS OF THOSE
9 INDIVIDUALS WHO ARE CERTIFIED AND INDIVIDUALS WHO ARE IN THE
10 CERTIFICATION PROCESS.
- 11 40.8 DE-CERTIFICATION
- 12 40.8.1 THE SECRETARY OF STATE HAS THE AUTHORITY TO DE-CERTIFY ANY PERSON WHO
13 DOES NOT FULFILL THE CONTINUING EDUCATION REQUIREMENTS.
- 14 40.8.2 IF A CERTIFICATION LAPSES WITHIN 18 MONTHS, THE PERSON SHALL BE REQUIRED
15 TO MAKE UP THE CONTINUING EDUCATION CREDITS TO MAINTAIN CERTIFICATION.
- 16 40.8.3 IF A CERTIFICATION LAPSES WITHIN A PERIOD GREATER THAN 18 MONTHS, THE
17 PERSON SHALL BE REQUIRED TO FULFILL ALL THE NECESSARY CERTIFICATION
18 REQUIREMENTS AND RE-APPLY FOR CERTIFICATION.
- 19 40.8.4 THE ADVISORY BOARD CREATED SHALL HAVE THE AUTHORITY TO REVIEW ALL DE-
20 CERTIFICATIONS AND TAKE INTO ACCOUNT ANY EXTENUATING CIRCUMSTANCES
21 REGARDING RE-CERTIFICATION.
- 22 40.9 PERSONS ATTENDING THE MAY 2004 SECRETARY OF STATE TRAINING SHALL RECEIVE THE
23 EQUIVALENT OF THREE ELECTIVE CREDITS.
- 24 40.10 CREDIT FOR TEACHING CLASSES
- 25 40.10.1 A PERSON WHO TEACHES A CLASS AS PART OF THE CERTIFICATION SHALL
26 RECEIVE THE EQUIVALENT OF TWO CORE CREDITS, OR THREE ELECTIVE CREDITS.
- 27 40.11 INTENT OF THIS RULE
- 28 40.11.1 IT IS THE INTENT OF THIS RULE THAT THE SECRETARY OF STATE AND THE
29 ADVISORY BOARD DEVELOP REGIONAL TRAININGS TO MAKE CERTIFICATION AND
30 EDUCATION MORE ACCESSIBLE. IT IS THE INTENT THAT THE SECRETARY OF STATE
31 EXPLORE VIRTUAL AND WEB-BASED TRAINING FOR USE AS PART OF THE
32 CERTIFICATION AND EDUCATION PROCESS.
- 33 **RULE 41. RULES CONCERNING CANVASSING**
- 34 **41.1 DEFINITIONS**
- 35 (A) "CANVASS" SHALL MEAN THE AUDIT FUNCTION OF THE ELECTION AND
36 THE PROCESS OF RECONCILING THE NUMBER OF BALLOTS COUNTED TO THE NUMBER
37 OF VOTERS WHO VOTED. THE CANVASS ALSO INCLUDES THE PROCESS OF
38 RECONCILING DETAILED BALLOT LOGS AND STATEMENT OF BALLOT FORMS.
- 39 (B) "CANVASS WORKERS" SHALL MEAN WORKERS APPOINTED OR HIRED BY
40 THE DESIGNATED ELECTION OFFICIAL TO ASSIST IN THE PREPARATION AND
41 CONDUCT OF THE CANVASS.
- 42 (C) "STATEMENT OF BALLOT FORMS" SHALL MEAN THE FORM USED AT THE
43 POLLING LOCATION PURSUANT TO 1-7-502(2) C.R.S AND 1-7-601(2) C.R.S.
44 THAT ACCOUNTS FOR ALL BALLOT AT THAT LOCATION. THE FORM INCLUDES
45 INFORMATION REQUIRED BY THIS RULE.
- 46 **41.2 DETAILED BALLOT LOG**

- 1 **41.2.1 THE DESIGNATED ELECTION OFFICIAL SHALL KEEP A DETAILED LOG OF ALL**
2 **BALLOTS. THE DESIGNATED ELECTION OFFICIAL SHALL BEGIN THE LOG AS**
3 **SOON AS BALLOTS ARE ORDERED AND RECEIVED. THE LOG SHALL INCLUDE THE**
4 **POLLING LOCATION AND/OR PRECINCT NUMBER(S), BALLOT STYLE(S), AND**
5 **ACCOUNT FOR EVERY BALLOT THAT IS RECEIVED AND DISTRIBUTED. THE**
6 **DETAILED BALLOT LOG SHALL BE RECONCILED AT THE CONCLUSION OF EACH**
7 **WORKDAY.**
- 8 **41.2.2 THE DESIGNATED ELECTION OFFICIAL SHALL KEEP AND RECONCILE DAILY LOGS**
9 **OF ABSENTEE, MAIL AND EARLY VOTING BALLOTS.**
- 10 **41.2.3 THE DESIGNATED ELECTION OFFICIAL SHALL INDICATE IN THE DETAILED LOG**
11 **THE NUMBER OF PAPER BALLOTS THAT ARE SENT TO EACH POLLING LOCATION**
12 **FOR USE ON ELECTION DAY.**
- 13 **41.2.4 ALL REQUIRED LOGS MAY BE KEPT EITHER BY ELECTRONIC OR MANUAL MEANS.**
- 14 **41.3 ELECTION DAY TRACKING PROCESS**
- 15 **41.3.1 THE DESIGNATE ELECTION OFFICIAL SHALL SUPPLY EACH POLLING LOCATION**
16 **WITH A STATEMENT OF BALLOTS FORM. COMBINED PRECINCTS MAY USE ONE**
17 **FORM. THE FORM SHALL INCLUDE A PLACE FOR THE JUDGES TO ACCOUNT FOR**
18 **THE FOLLOWING INFORMATION:**
- 19 **(A) THE NAME OR NUMBER(S) OF THE PRECINCT OR VOTE CENTER;**
20 **(B) THE NUMBER OF BALLOTS PROVIDED TO THE POLLING LOCATION;**
21 **(C) THE NUMBER OF BALLOTS CAST;**
22 **(D) THE NUMBER OF UNVOTED BALLOTS**
23 **(E) THE NUMBER OF DAMAGED OR SPOILED BALLOTS; AND**
24 **(F) THE NUMBER OF VOTED PROVISIONAL BALLOTS.**
- 25 **41.3.2 THE TOTAL NUMBER OF VOTED BALLOTS SHOULD BE RECONCILED TO**
26 **THE NUMBER OF VOTERS WHO VOTED.**
- 27 **41.3.3 THE TOTAL NUMBER OF VOTED BALLOTS, SPOILED OR DAMAGED BALLOTS,**
28 **PROVISIONAL BALLOTS AND UNVOTED BALLOTS SHOULD BE RECONCILED TO BE**
29 **THE SAME AS THE NUMBER OF TOTAL BALLOTS RECEIVED AT THE POLLING**
30 **LOCATION BEFORE VOTING BEGINS.**
- 31 **41.3.4 THE DESIGNATED ELECTION OFFICIAL SHALL ENSURE THAT THE TOTAL OF THE**
32 **NUMBR OF PEOPLE WHO SIGNED THE POLLBOOK IS RECONCILED TO THE TOTAL**
33 **OF THE NUMBER OF BALLOTS CAST.**
- 34 **41.3.5 IF THERE IS A DISCREPANCY IN THE NUMBERS ON THE STATEMENT OF BALLOTS**
35 **FORM, THE JUDGE SHALL MAKE WRITTEN NOTATION EXPLAINING WHY THE**
36 **NUMBERS DO NOT BALANCE (FOR EXAMPLE, VOTER SIGNED IN BUT LEFT THE**
37 **POLLING PLACE WITHOUT VOTING, ETC.).**
- 38 **41.3.6 THE JUDGES SHALL RETURN THE COMPLETED STATEMENT OF BALLOTS FORM**
39 **TO THE DESIGNATED ELECTION OFFICIAL WITH THE OTHER PRECINCT SUPPLIES**
40 **AND MAIL A DUPLICATE COPY PURSUANT TO 1-7-505 C.R.S.**
- 41
- 42 **41.4 DESIGNATED ELECTION OFFICIAL’S DISPOSITION OF FORMS**
- 43 **41.4.1 THE DESIGNATED ELECTION OFFICIAL SHALL REVIEW THE STATEMENT OF**
44 **BALLOTS FORM AND ENSURE THAT IT IS COMPLETE AND CORRECT.**
- 45 **41.4.2 IF THE DESIGNATED ELECTION OFFICIAL OR THE CANVASS BOARD DISCOVERS A**
46 **PROBLEM WITH THE STATEMENT OF BALLOTS FORM THAT CANNOT BE EASILY**

1 RESOLVED, HE OR SHE SHALL HAVE THE RIGHT TO CONTACT THE ELECTION
2 JUDGES AND ENSURE THAT THE DISCREPANCY IS EXPLAINED OR CORRECTED.

3 **41.5 PROCEDURES FOR THE DAY OF THE CANVASS**

4 **41.5.1 IN ORDER FOR THE CANVASS BORAD ESTABLISHED PURSUANT TO 1-10-**
5 **101 C.R.S. TO PERFORM ITS DUTIES, PURSUANT TO 1-10-101.5 C.R.S.,**
6 **THE DESIGNATED ELECTION OFFICIAL SHALL PROVIDE THE FOLLOWING**
7 **INFORMATION;;**

- 8
- 9 (A) THE NAME OF EACH CANDIDATE RECEIVING VOTES, THE OFFICE, AND
10 THE TOTAL NUMBER OF VOTES RECEIVED;
- 11 (B) THE NUMBER/LETTER OF EACH BALLOT ISSUE OR QUESTION AND THE
12 VOTES RECEIVED;
- 13 (C) THE NUMBER OF VOTERS WHO VOTED EARLY;
- 14 (D) THE NUMBER OF ABSENTEE OR MAIL BALLOTS CAST, INCLUDING THE
15 NUBER ACCEPTED AND REJECTED;
- 16 (E) THE NUMBER OF PROVISIONAL BALLOTS COUNTED.

17

18 41.5.2 THE CANVASS BOARD SHALL CONFIRM THAT THE NUMBER OF BALLOTS CAST IS
19 LESS THAN OR EQUAL TO THE NUMBER OF PEOPLE WHO ACTUALLY VOTED IN EACH
20 PRECINCT OR VOTE CENTER.

21 41.5.3 THE DESIGNATED ELECTION OFFICIAL SHALL USE A CANVASS FORM THAT IS
22 APPROVED BY THE SECRETARY OF STATE.

23 **41.5.4 ANY WRITTEN DOCUMENTATION REGARDING OFFICIAL NUMBERS SHALL BE**
24 **INCLUDED AS PART OF THE CANVASS.**

25 41.6 OFFICIAL ABSTRACT

26 **41.6.1 THE DESIGNATED ELECTION OFFICIAL SHALL ENSURE THAT THE NUMBER OF**
27 **ACTIVE VOTERS ON ELECTION DAY PURSUANT TO 1-10-105(5)(C) C.R.S. IS THE NUMBER**
28 **USED ON THE OFFICIAL ABSTRACT.**

29 **41.6.2 THE OFFICIAL ABSTRACT SHALL BE COMPILED ON A FORMAT APPROVED BY THE**
30 **SECRETARY OF STATE.**

31 **41.6.3 THE OFFICIAL ABSTRACT SHALL INCLUDE, BY PRECINCT/BALLOT STYLE OR**
32 **VOTE CENTER, WHERE APPLICABLE:**

- 33 (A) THE STATEMENT OF VOTES COUNTED BY RACE AND BALLOT QUESTION
34 OR ISSUE;
- 35 (B) THE TOTAL ACTIVE REGISTERED ELECTORS IN THE PRECINCT AND THE
36 TOTAL FOR THE JURISDICTION HOLDING THE ELECTION;
- 37 (C) THE TOTAL NUMBER OF ELECTORS VOTING IN EACH PRECINCT, AND THE
38 TOTAL FOR THE JURISDICTION HOLDING THE ELECTION;
- 39 (D) THE NUMBER OF VOTERS WHO VOTED EARLY;
- 40 (E) THE NUMBER OF EMERGENCY REGISTRATIONS;
- 41 (F) THE NUMBER OF ABSENTEE OR MAIL BALLOTS COUNTED AND THE
42 NUMBER REJECTED;
- 43 (G) THE NUMBER OF PROVISIONAL BALLOTS COUNTED AND THE NUMBER
44 REJECTED LISTED BY EACH REJECTION CODE PURSUANT TO **RULE 26.5.4;**
45 **AND**
- 46 (H) THE NUMBER OF DAMAGED AND SPOILED BALLOTS.

- 1 **41.7 THE ABSTRACT SHALL BE THE OFFICIAL, PERMANENT RECORD**
2 **41.7.1 THE DESIGNATED ELECTION OFFICIAL SHALL KEEP ALL OFFICIAL CANVASS**
3 **REPORTS AND FORMS AS PART OF THE OFFICIAL PERMANENT ELECTION**
4 **RECORD.**
- 5 **41.8 APPOINTMENT OF CANVASS WORKERS**
6 **41.8.1 THE DESIGNATED ELECTION OFFICIAL MAY UTILIZE CANVASS WORKERS TO**
7 **ASSIST IN THE PREPARATION AND CONDUCT OF THE CANVASS.**
- 8 **41.9 VOTER HISTORY**
9 **41.9.1 AFTER THE CANVASS PROCESS IS COMPLETED, THE DESIGNATED ELECTION**
10 **OFFICIAL SHALL GIVE CREDIT TO EACH VOTER WHO VOTES ABSENTEE, BY MAIL,**
11 **AT AN EARLY VOTING SITE, OR AT A POLLING LOCATION.**
- 12 **41.9.2 IF THE VOTER HISTORY RECORDS DO NOT MATCH THE NUMBER OF VOTERS WHO**
13 **VOTED AT THAT ELECTION, THE DESIGNATED ELECTION OFFICIAL SHALL**
14 **ENSURE THE FOLLOWING:**
15 (A) EACH VOTER WAS GIVEN CREDIT FOR VOTING; AND
16 (B) ALL POLLBOOKS AND SIGNATURE CARDS ARE ACCOUNTED FOR.
- 17 **41.9.3 ALL RESEARCH CONCERNING DISCREPANCIES SHALL BE EXPLAINED AND**
18 **DOCUMENTED.**
- 19 **41.10 WRITTEN COMPLAINTS. IN ACCORDANCE WITH 1-7-514(2)(B) C.R.S., THE DESIGNATED**
20 **ELECTION OFFICIAL SHALL PROVIDE IN CANVASS BOARD MATERIALS ANY WRITTEN**
21 **COMPLAINT ABOUT A VOTING DEVICE SUBMITTED BY A REGISTERED ELECTOR, AND, IF**
22 **RESOLVED, HOW IT WAS RESOLVED AND IF PENDING, A PROPOSAL FOR HOW THE ISSUE**
23 **WILL BE RESOLVED.**
- 24 **RULE 42. RULES CONCERNING USE OF FACSIMILE FOR ADMINISTRATIVE OR MEDICAL**
25 **EMERGENCY OUTSIDE OF THE UOCAVA CONTEXT.**
- 26
- 27 42.1 PURSUANT TO 1-8-115 C.R.S., THE DESIGNATED ELECTION OFFICIAL MAY USE MEANS OF
28 ELECTRONIC TRANSFER TO PROVIDE AN ABSENTEE BALLOT TO THE ELIGIBLE ELECTOR FOR
29 AN ADMINISTRATIVE OR MEDICAL EMERGENCY FOLLOWING THE PROCEDURES OUTLINED IN
30 1-8-115 C.R.S. AND THIS RULE.
- 31 42.2 "ELECTRONIC TRANSFER" SHALL MEAN THE USE OF FACSIMILE AND SHALL NOT INCLUDE
32 THE USE OF E-MAIL UNDER 1-8-115 C. R. S.
- 33 42.3 THE ABSENTEE BALLOT SHALL NOT BE RETURNED VIA ANY ELECTRONIC MEANS.
- 34 42.4 ABSENTEE BALLOTS SENT BY FACSIMILE TRANSMISSION SHALL INCLUDE ALL RACES,
35 BALLOT ISSUES, AND QUESTIONS ON WHICH THE ELECTOR MAY VOTE. COUNTIES ARE
36 ENCOURAGED TO WORK WITH THEIR VENDORS TO DEVELOP A BALLOT THAT IS CLEARLY
37 LEGIBLE TO THE ELECTOR TO INCREASE THE READABILITY OF THE BALLOT AND TO AVOID
38 POSSIBLE MISINTERPRETATIONS OF THE ELECTOR'S INTENDED CHOICE BECAUSE OF POOR
39 TRANSMISSION OF THE DOCUMENT.
- 40 42.5 INSTRUCTIONS FAXED TO THE ELECTOR WITH THE ABSENTEE BALLOT SHALL INCLUDE THE
41 FOLLOWING INFORMATION:
42 (A) THE NAME OF THE ELECTOR;
43 (B) THE RECIPIENT'S FAX NUMBER;
44 (C) THE TOTAL NUMBER OF PAGES TO BE TRANSMITTED;
45 (D) THE TOTAL NUMBER OF BALLOT PAGES;

- 1 (E) THE TELEPHONE NUMBER OR E-MAIL ADDRESS WHERE THE ELIGIBLE
2 ELECTOR MAY SEND QUESTIONS REGARDING THE FAXED ABSENTEE BALLOT;
3 (F) A NOTICE THAT THE RECIPIENT SHALL NOT DUPLICATE THE BALLOT FOR ANY
4 OTHER VOTER;
5 (G) THE ABSENTEE BALLOT SHALL BE RETURNED ONLY BY MAIL OR HAND
6 DELIVERED. A FAXED BALLOT WILL NOT BE ACCEPTED;
7 (H) RETURN ADDRESS INFORMATION FOR THE DESIGNATED ELECTION OFFICIAL
8 AND INSTRUCTIONS TO MARK, "OFFICIAL BALLOT ENCLOSED" ON THE
9 ELECTOR'S RETURN ENVELOPE;
10 (I) A NOTICE THAT THE BALLOT MUST BE RECEIVED BY THE DESIGNATED
11 ELECTION OFFICIAL BY MAIL OR HAND DELIVERED NO LATER THAN 7:00 P.M.
12 MOUNTAIN STANDARD TIME ON ELECTION DAY; AND
13 (J) INSTRUCTIONS FOR RETURNING THE MEDICAL/ADMINISTRATIVE EMERGENCY
14 FORM.
- 15 42.6 THE TRANSMISSION SHALL ALSO INCLUDE AN ABSENTEE BALLOT SELF-AFFIRMATION
16 PURSUANT TO 1-8-114 (1) C. R. S.
- 17 42.7 THE FAX TRANSMISSION LOG AS WELL AS ANY OTHER FAX RECORD SHALL BE PART OF THE
18 OFFICIAL ELECTION RECORD.
- 19 42.7.1 A FAX TRANSMISSION LOG SHALL BE MAINTAINED BY THE DESIGNATED ELECTION
20 OFFICIAL OF EACH BALLOT SENT TO A VOTER BY FACSIMILE INDICATING:
21 (A) THE NAME OF THE VOTER;
22 (B) THE FAX NUMBER TO WHICH THE BALLOT WAS SENT;
23 (C) THE UNIQUE IDENTIFICATION NUMBER OF THE FAXED BALLOT;
24 (D) THE DATE THE BALLOT AND INSTRUCTIONS WERE FAXED; AND
25 (E) THE INITIALS OF THE DESIGNATED ELECTION OFFICIAL'S EMPLOYEE
26 SENDING THE FAX.
- 27 42.8 THE DESIGNATED ELECTION OFFICIAL SHALL FAX THE BLANK BALLOT WITH THE
28 INSTRUCTIONS TO THE FAX NUMBER PROVIDED BY THE ELECTOR. IF THE TRANSMISSION IS
29 UNSUCCESSFUL, THE DESIGNATED ELECTION OFFICIAL SHALL ATTEMPT TO FAX AT LEAST
30 TWO MORE TIMES AND MAKE REASONABLE EFFORT, IF POSSIBLE, TO ENSURE THE
31 TRANSMISSION WAS SUCCESSFUL.
- 32 42.9 UPON RECEIPT OF THE BALLOT, WHEN THE INFORMATION FROM THE SIGNED AFFIDAVIT HAS
33 BEEN VERIFIED, A BIPARTISAN TEAM OF JUDGES SHALL DUPLICATE THE BALLOT. DUPLICATING
34 JUDGES SHALL NOT REVEAL HOW THE ELECTOR HAS CAST HIS OR HER BALLOT.42.10 MEDICAL
35 EMERGENCY
- 36 42.10.1 FOR PURPOSES OF 1-8-115(1)(A) C.R.S. "SECOND DEGREE" IS DEFINED AS SPOUSE,
37 PARENTS, CHILDREN, BROTHERS AND SISTERS, GRANDPARENTS, AND
38 GRANDCHILDREN RELATED BY BLOOD OR MARRIAGE.
- 39 42.11 ADMINISTRATIVE EMERGENCY. IF THE DESIGNATED ELECTION OFFICIAL IS UNABLE TO
40 PROVIDE AN ABSENTEE BALLOT TO AN ELECTOR BY ANY OTHER MEANS, THE DESIGNATED
41 ELECTION OFFICIAL SHALL SEEK AUTHORITY FROM THE SECRETARY OF STATE TO PROVIDE
42 AN ABSENTEE BALLOT TO THE ELECTOR PURSUANT TO 1-8-115(4) C.R.S. USING FAX
43 TRANSMISSION.
- 44 42.11.1 THIS RULE 42.11 SHALL APPLY ONLY TO ELIGIBLE ELECTORS WHO ARE PROPERLY
45 REGISTERED AND HAVE TIMELY FILED FOR AN ABSENTEE BALLOT APPLICATION.

1 42.11.2 THE SECRETARY OF STATE SHALL DESIGNATE A POINT OF CONTACT FOR EACH
2 ELECTION FOR EMERGENCY ELECTRONIC TRANSFER REQUESTS NO LATER THAN
3 TWENTY-ONE (21) DAYS PRIOR TO AN ELECTION. THE SECRETARY OF STATE SHALL
4 NOTIFY THE COUNTIES BY E-MAIL WHO THE DESIGNATED POINT OF CONTACT SHALL
5 BE, AND POST THE CONTACT INFORMATION FOR THE DESIGNATED POINT OF
6 CONTACT ON THE SECRETARY OF STATE'S WEBSITE.

7 42.11.3 THE DESIGNATED ELECTION OFFICIAL SHALL SUBMIT THE REQUEST IN WRITING
8 FROM THE SECRETARY OF STATE USING THE EMERGENCY ELECTRONIC TRANSFER
9 FORM. E-MAIL IS THE PREFERRED METHOD OF COMMUNICATION. IF POSSIBLE, THE
10 DESIGNATED ELECTION OFFICIAL SHALL ATTEMPT TO CONSOLIDATE REQUESTS TO
11 THE SECRETARY OF STATE.

12 42.11.4 THE FORM FOR REQUESTING AN EMERGENCY ELECTRONIC TRANSFER SHALL BE
13 POSTED ON THE SECRETARY OF STATE'S WEBSITE. THE FORM MUST CONTAIN THE
14 FOLLOWING INFORMATION:

- 15 (A) CONTACT INFORMATION, INCLUDING NAME, ADDRESS, PHONE NUMBER, FAX
16 NUMBER, AND E-MAIL ADDRESS FOR THE DESIGNATED ELECTION OFFICIAL
17 OR THEIR DESIGNEE;
- 18 (B) DATE AND TIME OF REQUEST SENT BY DESIGNATED ELECTION OFFICIAL;
- 19 (C) CONFIRMATION E-MAIL TO DESIGNATED ELECTION OFFICIAL BY SECRETARY
20 OF STATE UPON RECEIPT OF REQUEST
- 21 (D) A SUGGESTED TIMEFRAME FOR THE SECRETARY OF STATE TO RESPOND;
- 22 (E) JUSTIFICATION AS TO WHY THE BALLOT(S) NEED TO BE SENT BY FAX, WHICH
23 INCLUDES THE FOLLOWING REQUIRED INFORMATION:
 - 24 (1) THE ELECTOR'S NAME;
 - 25 (2) WHEN THE ELECTOR APPLIED FOR THE ABSENTEE BALLOT;
 - 26 (3) THE DATE WHEN THE DESIGNATED ELECTION OFFICIAL SENT THE
27 ABSENTEE BALLOT TO THE ELECTOR (IF APPLICABLE);
 - 28 (4) THE DATE THE ELECTOR CONTACTED THE DESIGNATED ELECTION
29 OFFICIAL WITH INFORMATION REGARDING FAILURE TO RECEIVE THE
30 BALLOT;
 - 31 (5) A SUGGESTED TIMEFRAME FOR THE SECRETARY OF STATE TO
32 RESPOND;
 - 33 (6) THE QUANTITY OF BALLOTS TO BE SENT BY FAX; AND
 - 34 (7) APPROVAL OR DISAPPROVAL BY THE SECRETARY OF STATE; IF
35 DENIED, REASON FOR THE DENIAL .
- 36 (H) CONFIRMATION E-MAIL FROM THE DESIGNATED ELECTION OFFICIAL TO
37 SECRETARY OF STATE UPON RECEIPT OF APPROVAL OR DISAPPROVAL.

38 42.11.5 THE SECRETARY OF STATE SHALL RESPOND IN WRITING TO THE DESIGNATED
39 ELECTION OFFICIAL AS SOON AS POSSIBLE, BUT NO LATER THAN EIGHT (8) BUSINESS
40 HOURS AFTER RECEIPT OF THE REQUEST.

41 42.11.6 THE SECRETARY OF STATE SHALL HAVE THE ABILITY TO ISSUE A BLANKET
42 APPROVAL BY ELECTRONIC TRANSFER.

43 **RULE 43. COUNTY SECURITY PROCEDURES**

44 43.1 PURSUANT TO 1-5-616(5) C.R.S., EACH COUNTY SHALL FILE WITH THE SECRETARY OF
45 STATE SECURITY PROCEDURES THAT MEET THE MINIMUM STANDARDS SET FORTH IN THIS
46 RULE.

- 1 43.2 THE COUNTY SHALL FILE SECURITY PROCEDURES ANNUALLY NO LATER THAN SIXTY (60)
2 DAYS PRIOR TO THE FIRST ELECTION IN WHICH THE PROCEDURES WILL BE USED.
- 3 43.3 IF NO CHANGES HAVE OCCURRED SINCE THE LAST SECURITY PROCEDURES FILED, THE
4 COUNTY SHALL FILE A STATEMENT TO THAT EFFECT.
- 5 43.4 REVISIONS TO PREVIOUSLY FILED SECURITY PROCEDURES SHALL CLEARLY STATE WHICH
6 PART OF THE PROCEDURES PREVIOUSLY FILED HAVE BEEN REVISED.
- 7 43.5 EACH DESIGNATED ELECTION OFFICIAL MAY CHANGE THE SECURITY PROCEDURES WITHIN
8 SIXTY (60) DAYS OF AN ELECTION AS A RESULT OF AN EMERGENCY SITUATION OR OTHER
9 UNFORESEEN CIRCUMSTANCE, AND DOCUMENT ANY CHANGES. THE DESIGNATED ELECTION
10 OFFICIAL SHALL FILE ANY REVISIONS WITH THE SECRETARY OF STATE WITHIN FIVE (5)
11 DAYS OF THE CHANGE.
- 12 43.6 IF, PURSUANT TO 1-5-616(5)(B) C.R.S., THE SECRETARY OF STATE IS UNABLE TO
13 COMPLETE ITS REVIEW, THE PROCEDURES OR REVISIONS SHALL BE TEMPORARILY APPROVED
14 UNTIL SUCH TIME AS THE REVIEW IS COMPLETED. THE SECRETARY OF STATE SHALL NOTIFY
15 THE COUNTY OF TEMPORARY APPROVAL.
- 16 43.7 SECURITY PROCEDURES SHALL AT A MINIMUM INCLUDE, IF APPLICABLE:
- 17 43.7.1 THE PHYSICAL SECURITY OF ELECTION EQUIPMENT, SOFTWARE AND FIRMWARE,
18 ELECTION MATERIALS, POLLING PLACES AND COUNTING CENTERS, AND EQUIPMENT
19 STORAGE LOCATIONS, INCLUDING BUT NOT LIMITED TO:
- 20 (A) LOCKING MECHANISMS AND SEALS;
21 (B) INDIVIDUALS WITH ACCESS TO KEYS, DOOR CODES, VAULT COMBINATIONS;
22 (C) TEMPERATURE CONTROL (IF NECESSARY);
23 (D) SECURITY CAMERAS OR OTHER SURVEILLANCE;
24 (E) EQUIPMENT MAINTENANCE PROCEDURES (SEE RULE 11);
25 (F) TRANSPORTATION OF EQUIPMENT, BALLOT BOXES, AND BALLOTS ON
26 ELECTION DAY;
27 (G) EMERGENCY CONTINGENCY PLANS FOR EQUIPMENT AND POLLING PLACES;
28 (H) ANY OTHER PROCEDURES USED TO MAINTAIN PHYSICAL SECURITY;
29 (I) INTERNAL CONTROLS FOR THE VOTING SYSTEM INCLUDING SOFTWARE AND
30 HARDWARE ACCESS CONTROLS AND PASSWORD MANAGEMENT; AND
31 (J) SECURITY TRAINING FOR ELECTION JUDGES.
- 32 43.8 THE DESIGNATED ELECTION OFFICIAL SHALL MAINTAIN A FILE CONTAINING ALL
33 REFERENCED FORMS, SCHEDULES, LOGS, AND CHECKLISTS. THE SECRETARY OF STATE HAS
34 THE AUTHORITY TO INSPECT THE FILE.
- 35 43.9 INCLUDED IN THE SECURITY PROCEDURES FILED WITH THE SECRETARY OF STATE SHALL BE
36 A SECTION ENTITLED "CONTINGENCY PLAN." THE CONTINGENCY PLAN SHALL INCLUDE:
- 37 (A) EVACUATION PROCEDURES FOR EMERGENCY SITUATIONS INCLUDING FIRE,
38 BOMB THREAT, CIVIL UNREST, AND ANY OTHER EMERGENCY SITUATIONS
39 IDENTIFIED BY THE DESIGNATED ELECTION OFFICIAL;
40 (B) BACK UP PLANS FOR EMERGENCY SITUATIONS INCLUDING FIRE, SEVERE
41 WEATHER, BOMB THREAT, CIVIL UNREST, ELECTRICAL BLACKOUT,
42 EQUIPMENT FAILURE, AND ANY OTHER EMERGENCY SITUATIONS IDENTIFIED
43 BY THE DESIGNATED ELECTION OFFICIAL;
44 (C) AN EMERGENCY CHECKLIST FOR ELECTION JUDGES; AND
45 (D) A LIST OF EMERGENCY CONTACT NUMBERS PROVIDED TO ELECTION JUDGES.

1 43.10 COMPUTER ROOM ACCESS SHALL BE LIMITED TO AUTHORIZED PERSONNEL ONLY, AND THE
2 DELIVERY OF BALLOTS BETWEEN THE PREPARATION ROOM AND COMPUTER ROOM SHALL BE
3 PERFORMED BY MESSENGERS OR RUNNERS WEARING DISTINGUISHING IDENTIFICATION.

4 **RULE 44 RULES REGULATING VOTER REGISTRATION DRIVES**

5 **4.1 STATEMENT OF INTENT**

6 4.1.1 IN ACCORDANCE WITH 1-2-701 *ET SEQ.* C.R.S., THE ORGANIZER OF A VOTER
7 REGISTRATION DRIVE ("VRD") SHALL FILE A STATEMENT OF INTENT WITH THE
8 SECRETARY OF STATE TO CONDUCT A VOTER REGISTRATION DRIVE ON A FORM PRESCRIBED
9 BY THE SECRETARY OF STATE. THE STATEMENT OF INTENT SHALL INCLUDE THE
10 FOLLOWING INFORMATION:

- 11 (A) THE NAME OF THE ORGANIZATION AND THE NAME OF THE PARENT
12 ORGANIZATION, IF APPLICABLE;
- 13 (B) THE CONTACT INFORMATION FOR THE ORGANIZATION
- 14 (C) THE NAME OF THE AGENT IS A COLORADO RESIDENT AND THE CONTACT
15 INFORMATION FOR THAT AGENT;
- 16 (D) A STATEMENT SPECIFYING THE COUNTIES IN WHICH THE VRD INTENDS TO
17 OPERATE;
- 18 (E) A NOTICE THAT THE VOTER REGISTRATION DRIVE NUMBER EXPIRES AT THE
19 END OF THE CALENDAR YEAR; AND
- 20 (F) A SIGNATURE LINE REQUIRING THE ORGANIZER'S SIGNATURE.

21 44.1.2 ANY AMENDMENTS TO THE STATEMENT OF INTENT SHALL BE FILED IN WRITING
22 WITH THE SECRETARY OF STATE. AMENDMENTS MAY BE MADE BY FAX, EMAIL,
23 MAIL OR IN PERSON.

24 (A) **ANY AMENDMENTS TO THE STATEMENT OF INTENT CONCERNING THE**
25 **COUNTY IN WHICH THE VRD WILL CONDUCT A DRIVE SHALL BE FILED A**
26 **MINIMUM OF THREE (3) BUSINESS DAYS PRIOR TO COMMENCING VOTER**
27 **REGISTRATION ACTIVITY IN A GIVEN COUNTY.**

28 44.1.3 THE SECRETARY OF STATE SHALL IMMEDIATELY ATTEMPT TO VERIFY THE
29 INFORMATION PROVIDED IN THE STATEMENT OF INTENT PRIOR TO ISSUING A
30 NUMBER TO THE VRD ORGANIZER. THE SECRETARY OF STATE MAY DENY A
31 NUMBER TO THE VOTER REGISTRATION DRIVE ORGANIZER IF THE INFORMATION
32 PROVIDED ON THE STATEMENT OF INTENT CANNOT BE VERIFIED.

33 44.1.4 THE LAST DAY FOR A VRD TO FILE A STATEMENT OF INTENT WITH THE SECRETARY
34 OF STATE SHALL BE THIRTY (30) DAYS BEFORE THE GENERAL ELECTION IN A GIVEN
35 CALENDAR YEAR.

36 **44.2 TRAINING**

37 44.2.1 THE ORGANIZER OF THE VRD SHALL, BEFORE COMMENCING THE DISTRIBUTION OR
38 CIRCULATION OF VOTER REGISTRATION APPLICATIONS, COMPLETE A TRAINING
39 PROVIDED BY THE SECRETARY OF STATE.

40 44.2.3 IN ADDITION TO TRAINING FOR THE ORGANIZER, THE SECRETARY OF STATE SHALL
41 MAKE AVAILABLE INFORMATION FOR THE ORGANIZER TO TRAIN INDIVIDUAL
42 CIRCULATORS. ORGANIZERS SHALL PROVIDE TRAINING TO ALL CIRCULATORS.
43 **ORGANIZERS SHALL OBTAIN AND MAINTAIN ON FILE SIGNED ATTESTATIONS**
44 **FROM EACH CIRCULATOR THAT HE OR SHE WILL ADHERE TO ALL THE**
45 **REQUIREMENTS OF THE SECRETARY OF STATE ELECTION RULES AND THE**
46 **COLORADO REVISED STATUTES PERTAINING TO ELECTIONS, AND THAT THEY**

1 **ARE AWARE OF THE PENALTIES ASSOCIATED WITH THE MISHANDLING OF VOTER**
2 **REGISTRATION APPLICATION FORMS. THE ORGANIZERS SHALL FURNISH THE**
3 **CIRCULATOR ATTESTATIONS TO THE SECRETARY OF STATE UPON REQUEST.**

4 44.2.4 THE MANDATORY TRAINING PROVIDED BY THE SECRETARY OF STATE SHALL
5 INCLUDE BUT NOT BE LIMITED TO:

- 6 (A) THE REQUIREMENT TO USE THE STANDARD VOTER REGISTRATION
7 APPLICATION FORM;
- 8 (B) INFORMATION ON WHERE TO OBTAIN THE STANDARD VOTER REGISTRATION
9 APPLICATION FORM;
- 10 (C) INFORMATION ON HOW TO ENSURE THAT A FORM IS FILLED OUT COMPLETELY;
11 INCLUDING WHICH FIELDS ARE OPTIONAL AND WHICH ARE REQUIRED, AND
12 HOW TO FILL OUT THE RECEIPT PORTION OF THE FORM;
- 13 (D) NOTICE OF STATUTORY DEADLINES RELATING TO VOTER REGISTRATION
14 APPLICATIONS FORMS AND VOTER REGISTRATION DRIVES;
- 15 (E) THE REQUIREMENTS FOR WHEN AND WHERE THE VOTER REGISTRATION
16 APPLICATIONS FORMS MUST BE TURNED IN;
- 17 (F) PENALTIES FOR VIOLATING STATUTORY PROHIBITIONS INCLUDING FRAUD,
18 INTIMIDATION, MISHANDLING FORMS, FAILING TO TURN IN FORMS AND OTHER
19 PENALTIES RELEVANT TO VOTER REGISTRATION DRIVES;
- 20 (G) THE HANDLING AND TREATMENT OF CONFIDENTIAL INFORMATION ON THE
21 VOTER REGISTRATION APPLICATION FORMS; AND
- 22 (H) NOTICE THAT CIRCULATORS SHALL NOT BE PAID PER VOTER REGISTRATION
23 APPLICATION, BUT IF COMPENSATED, SHALL BE PAID BY THE HOUR OR DAY.

24 43.2.5 AFTER COMPLETING THE TRAINING, THE ORGANIZER SHALL SIGN AN
25 ACKNOWLEDGEMENT THAT THE TRAINING HAS BEEN COMPLETED AND THAT HE OR
26 SHE HAS BEEN DULY INFORMED OF RULES, LAWS AND PENALTIES RELATING TO
27 VOTER REGISTRATION DRIVES.

28 **44.3 NUMBER ASSIGNED.** AFTER THE ORGANIZER COMPLETES THE REQUIRED TRAINING, THE
29 SECRETARY OF STATE SHALL ASSIGN A UNIQUE NUMBER TO THE VRD THAT MEETS THE
30 REQUIREMENTS OF 1-2-701 C.R.S. AND THIS RULE. AFTER ISSUING A UNIQUE NUMBER TO
31 THE VOTER REGISTRATION DRIVE, THE SECRETARY OF STATE SHALL:

- 32 (A) ADVISE THE VRD ORGANIZER OF THE UNIQUE NUMBER;
- 33 (B) NOTIFY THE COUNTY CLERKS WITHIN 24 HOURS OF EACH REGISTERED VOTER
34 REGISTRATION DRIVE REGISTERED WITH THE SECRETARY OF STATE; AND
- 35 (C) POST THE ORGANIZATION'S NAME AND CONTACT PERSON ON THE SOS
36 WEBSITE.

37 **44.4 VOTER REGISTRATION DRIVE VOTER APPLICATION FORMS**

38 44.4.1 The Secretary of State shall approve a Voter Registration Application Form to be
39 used exclusively by the VRD that shall include a tear off receipt. All persons
40 conducting a VRD shall use the official, approved Form.4.4.2 The Secretary
41 of State and county clerks shall make available the official, approved Voter
42 Registration Drive Application Forms to the VRD organizer. No other voter
43 registration application form may be used by a VRD.

44 44.4.3 THE ORGANIZER SHALL BE RESPONSIBLE FOR PLACING THE VRD NUMBER ON THE
45 APPLICATION FORM AND THE RECEIPT PORTION OF THE FORM.

- 1 44.4.4 THE PERSON CIRCULATING THE VOTER REGISTRATION APPLICATION FORMS SHALL
2 ENSURE THAT THE TEAR-OFF RECEIPT ON THE APPLICATION IS COMPLETED AND
3 GIVEN TO THE APPLICANT. THE PERSON CIRCULATING THE VOTER APPLICATION
4 FORMS SHALL ADVISE THE APPLICANT THAT THE RECEIPT MAY BE NEEDED WHEN HE
5 OR SHE VOTES.
- 6 44.4.5 THE VRD ORGANIZER IS NOT ELIGIBLE TO RECEIVE VOTER REGISTRATION
7 APPLICATION FORMS UNTIL THE ORGANIZER HAS COMPLETED TRAINING, SIGNED
8 THE STATEMENT OF INTENT, COMPLETED AND SIGNED THE ACKNOWLEDGEMENT,
9 AND BEEN ASSIGNED A NUMBER.
- 10 44.4.6 ANY VOTER REGISTRATION DRIVE THAT PROVIDES A VOTER REGISTRATION
11 APPLICATION ON ITS WEBSITE OR A LINK TO SUCH VOTER REGISTRATION FORM MUST
12 DIRECT THE APPLICANT TO RETURN THE COMPLETED FORM DIRECTLY TO THE
13 COUNTY CLERK AND RECORDER OF THE APPLICANT'S LEGAL RESIDENCE. NO VOTER
14 REGISTRATION DRIVE MAY PROVIDE A VOTER REGISTRATION FORM ON ITS WEBSITE
15 OR A LINK TO SUCH VOTER REGISTRATION FORM WHICH INSTRUCTS OR DIRECTS, IN
16 ANY WAY, THE APPLICANT TO RETURN THE COMPLETED FORM TO ANYONE OR ANY
17 GROUP OTHER THAN DIRECTLY TO THE COUNTY CLERK AND RECORDER OF THE
18 APPLICANT'S LEGAL RESIDENCE OR, IN THE CASE OF OVERSEAS ELECTORS OR
19 UOCAVA ELECTORS, THE COUNTY CLERK AND RECORDER OR THE SECRETARY OF
20 STATE
21
22