

DEPARTMENT OF TRANSPORTATION

Transportation Commission and Office of Transportation Safety

STATE HIGHWAY ACCESS CODE

2 CCR 601-1

[Editor's Notes follow the text of the rules at the end of this CCR Document.]

Section One Introduction

1.1 Authority:

- (1) This Code is promulgated pursuant to section 43-2-147(4), C.R.S. which directs the Transportation Commission of Colorado to adopt a State Highway Access Code applicable on all state highways. Section 43-2-147(1), C.R.S., authorizes the Department of Transportation and local governments to regulate vehicular access to or from any public highway under their respective jurisdiction from or to property adjoining a public highway.

1.2 Purpose:

- (1) Colorado's state highway system constitutes a valuable resource and a major public and private investment. It is the purpose of the Code to provide procedures and standards to aid in the management of that investment and to protect the public health, safety and welfare, to maintain smooth traffic flow, to maintain highway right-of-way drainage, and to protect the functional level of state highways while considering state, regional, and local transportation needs and interests.
- (2) The Code recognizes that the State of Colorado, "State", must execute these prescribed duties within an environment where population growth will undoubtedly increase traffic volumes and operational pressures on the general street system. The Code establishes access criteria for each functional level of highway that recognize this increase in traffic volumes and operational pressures while meeting the intent and purposes of the Act.
- (3) Property owners have the right of reasonable access to the general street system. It is recognized that an access management system can influence decisions concerning the use of property. An affective access management system must recognize and consider its impacts on public and private land use decisions while meeting the intent and purposes of the Act.
- (4) Local governments control and operate streets and roads that are not a part of the state highway system. An effective access management system must consider the role that local streets and roads play in the overall transportation network.
- (5) All users of the state highway system should have the ability to move freely, to travel on a safe highway system, and to expect the efficient expenditure of public funds. An effective access management system can promote these expectations through appropriate control of access frequency, spacing, operation and design.
- (6) An effective access management system strives to protect the safety, traffic operations and the assigned functional purpose of the state highways while considering the access needs of the various elements of the general street system. Determining the best overall solution to access and circulation patterns is especially critical at locations where significant changes to the transportation system and/or adjacent land use have occurred or are proposed.

- (7) Through the administration of the State Highway Access Code, it is the intent of the Department of Transportation to work closely with property owners and local governments to provide reasonable access to the general street system that is safe, enhances the movement of traffic, and considers the vision and values that local communities have established for themselves.

1.3 Organization of Code

- (1) Section One describes the authority, purposes and structure of the Code, and defines those words that are technical or have specific definitions for the purposes of the Code. Section Two describes the administrative procedures for implementing the Code including the assignment of access categories. Section Three defines eight categories of highways based on function and provides criteria for determination of allowable access to the highway system. Section Four provides standards for the design and construction of all accesses. These standards are based upon criteria and specifications necessary to ensure the public health, welfare, and safety.

1.4 Implementation:

- (1) After August 31, 1981, no person, shall construct any access providing direct vehicular movement to or from any state highway from or to property in close proximity or abutting a state highway without an access permit issued by the designated issuing authority with the written approval of the Department. Within those jurisdictions where the local authority has returned issuing authority to the Department, the Department has sole authority to issue state highway access permits.
- (2) Access permits shall be issued only when the application is found to be in compliance with the Code. The issuing authority and the Department are authorized to impose terms and conditions as necessary and convenient to meet the requirements of the Code. In no event shall an access permit be issued or authorized if it is detrimental to the public health, welfare, and safety.
- (3) Direct access from a subdivision to the highway shall be permitted only if the proposed access meets the purposes and requirements of the Code. Local traffic from a subdivision abutting a state highway shall be served by an internal street system of adequate capacity, intersecting and connecting with state highways in a manner that is safe as well as consistent with the assigned access category (Code Section Three) and design requirements (Code Section Four). All new subdivision of property should provide access consistent with the standards of Sections Three and Four of the Code. The Department will work with appropriate local authority in the review of subdivision plats and other divisions of property to ensure that future access requirements of divided property are consistent with the purposes and standards of the Code and Act. The issuance of any permit, agreement, plat, subdivision, plan or correspondence shall not abrogate or limit the regulatory powers of the Department or issuing authority exercised in the protection of the public's health, safety and welfare.

1.5 Definitions and Abbreviations

These definitions and abbreviations are provided to explain certain technical words, phrases and abbreviations found in the Code. If a word is not further defined herein, it may be assumed that it is the common and acceptable meaning of the word found in any widely accepted English language dictionary.

- (1) "AADT" means the annual average two-way daily traffic volume. It represents the total traffic on a section of roadway for the year, divided by 365. It includes both weekday and weekend traffic volumes.
- (2) "Acceleration lane" means a speed-change lane, including tapered areas, for the purpose of enabling a vehicle entering a roadway to increase its speed to a rate at which it can more safely merge with through traffic. [§42-1-102(1), C.R.S.]

- (3) "Access" means any driveway or other point of entry and/or exit such as a street, road or highway that connects to the general street system. Where two public roadways intersect, the secondary roadway shall be considered the access.
- (4) "Access category" means one of eight categories described in Section Three of the Code, and determines the degree to which access to a state highway is controlled. Categories as they are assigned to specific highway segments are listed in the State Highway Access Category Assignment Schedule, 2 CCR 601-1A.
- (5) "Access control plan" means a roadway design plan which designates preferred access locations and their designs for the purpose of bringing those portions of roadway included in the access control plan into conformance with their functional classification to the extent feasible. [§ 43-2-147(8)(a), C.R.S.]
- (6) "Access operation" means the utilization of an access for its intended purpose, and includes all consequences or characteristics of that process, including access volumes, type of access traffic, access safety, time of the access activity, and the effect of such access on the state highway system.
- (7) "Act" means § 43-2-147, C.R.S.
- (8) "Administrative Procedure Act" means Article 4, Title 24, C.R.S.
- (9) "Appellant" means the person(s) who submit an appeal to the Transportation Commission pursuant to subsection 2.9 of the Code. Appellants may include the applicant or the permittee.
- (10) "Applicant" means any person, corporation, entity or agency applying for an access permit.
- (11) "Appropriate local authority" means the board of county commissioners if the driveway is to be located in the unincorporated area of a county, and the governing body of the municipality if the driveway is to be located within an incorporated municipality. [§ 43-2-147(8)(b), C.R.S.] Also referred to as the local authority, and local government.
- (12) "Auxiliary lane" means any additional special purpose lane such as, speed change lanes, hill climbing lanes, and turning lanes.
- (13) "AWD" means the daily average of weekday traffic volumes for a five day week expressed in the number of vehicles for a specific highway segment or access.
- (14) "Bandwidth" means the time in seconds or the percent of traffic signal cycle between a pair of parallel speed lines which delineate a progressive movement on a time-space diagram. It is a quantitative measurement of the through traffic capacity of a signal progression system. The greater the percentage of bandwidth, the higher the roadway capacity.
- (15) "Barrier Curb" means a raised vertical faced curb 6 inches to 9 inches high. Curbs are placed at the edge of the roadway to prevent vehicles from encroaching onto the roadside area. Barrier curbs may also be placed somewhere between the parking areas or internal driving areas and the highway to prevent vehicles from accessing the highway at locations that are not permitted and to help direct vehicles to the proper access locations.
- (16) "Capacity" means the ability of the highway to provide service to the volume of vehicles seeking to use the highway. Capacity is most often considered the maximum amount of traffic that can be accommodated by a highway during the peak hours of demand. Sometimes it refers to the entire roadway, and sometimes to a single lane.

- (17) "Chief Engineer" means the person who carries the official title of Chief Engineer of the Department.
- (18) "Clear Zone" means the total roadside border area, starting at the edge of the traveled way, available for safe use by errant vehicles. This area may consist of a shoulder, a recoverable slope, a nonrecoverable slope, and/or a clear run-out area. The desired width is dependent upon traffic volume, speeds, and roadway and roadside geometry.
- (19) "Code" means this State Highway Access Code, also known as chapter 2, Code of Colorado Regulations, section 601-1, also known as, 2 CCR 601-1.
- (20) "Commission" means the Transportation Commission of Colorado.
- (21) "Controlled-access highway" means every highway, street, or roadway in respect to which owners or occupants of abutting lands and other persons have no legal right of access to or from the same except at such points only and in such manner as may be determined by the public authority having jurisdiction over such highway, street, or roadway. [§ 42-1-102(18), C.R.S.]
- (22) "Control of access" means the condition in which the right of owners or occupants of land abutting or adjacent to a roadway is controlled by public authority.
- (23) "Cross-pan" means a concrete gutter across an access.
- (24) "Cross-street" or "cross-road" means the lower function roadway that crosses the main higher function facility.
- (25) "Curb-cut" means a depressed section of curbing to provide access to the abutting property. The most common type of private access in urban areas.
- (26) "Date of issue" means the date when the authorized Department official signs CDOT permit form 101.
- (27) "Date of Transmittal" means the date the Department forwards to the applicants, by U.S. mail or personal service, a permit for signature or a letter of denial. This date marks the end of the review period pursuant to the Act, § 43-2-147(5)(a), C.R.S.
- (28) "Day" means a calendar day, unless specifically stated otherwise in the applicable text of the Code. (See subsection 1.6)
- (29) "Deceleration lane" means a speed-change lane, including tapered areas, for the purpose of enabling a vehicle that is to make an exit to turn from a roadway to slow to the safe speed on the ramp ahead after it has left the mainstream of faster-moving traffic. [§ 42-1-102(23), C.R.S.]
- (30) "Department" means the Department of Transportation, State of Colorado. Also referred to as CDOT.
- (31) "Design Hourly Volume" ("DHV") means an hourly traffic volume determined for use in the geometric design of highways. It is the 30th highest hour vehicular volume experienced in a one year period.
- (32) "Divided highway" means a highway with separated roadways usually for traffic moving in opposite directions, such separation being indicated by depressed dividing strips, raised curbs, traffic islands, or other physical barriers so constructed as to impede vehicular traffic or otherwise indicated by standard pavement markings or other official traffic control devices as prescribed in the state traffic control manual. [§ 42-1-102(25), C.R.S.]
- (33) "Driveway" means an access that is not a public street, road, or highway.

- (34) "Field approach" or "Field access" means an access to undeveloped or agricultural property that has a yearly average use of less than one vehicle per day (2 vehicle trips).
- (35) "Freeway" means a state highway that has been designated by the Commission as a freeway in accordance with §43-3-101, C.R.S.
- (36) "Frontage Road" means a public roadway auxiliary to and generally alongside and parallel to the main highway, constructed for the purposes of providing direct property access, maintaining local road continuity and the controlling of direct access to the main highway.
- (37) "Functional classification" means a classification system that defines a public roadway according to its purposes in the local or statewide highway plans. [§ 43-2-147(8)(c), C.R.S.]
- (38) "General street system" means the interconnecting network of city streets, county roads, and state highways in an area. [§ 43-2-147(8)(d), C.R.S.]
- (39) "Grade separation" means a crossing of two roadways, or a roadway and a railroad, or a roadway and a pedestrian walkway, at different elevations.
- (40) "Gradient" or "grade" means the rate or percent change in slope, either ascending or descending from or along the highway. It is to be measured along the centerline of the roadway or access.
- (41) "Grandfathered" means a condition that existed prior to June 21, 1979 when section 43-2-147, C.R.S., was first signed into law, or a condition that was legal and conforming to an earlier Code edition or statute, where such conditions and use have not changed since the effective date of the change in law that made the condition non-conforming with current law.
- (42) "Highway" means the entire width between the boundary lines of every way publicly maintained when any part thereof is open to the use of the public for purposes of vehicular travel or the entire width of every way declared to be a public highway by any law of this state. [§42-1-102(43), C.R.S.] "Highway" includes bridges on the roadway and culverts, sluices, drains, ditches, waterways, embankments, retaining walls, trees, shrubs, and fences along or upon the same and within the right-of-way. [§ 43-1-203(1), C.R.S.]
- (43) "Highway Classification" means the classification of the highway for planning and management purposes as indicated on the current Colorado Highway Functional Classification Map as adopted by the Transportation Commission pursuant to Commission authority under article 1 of title 43 C.R.S.
- (44) "Ingress" means to leave the highway and enter upon the abutting property or intersecting roadway.
- (45) "Interchange" means a facility that grade separates intersecting roadways and provides directional ramps for access movements between the roadways. The structures and the ramps are considered part of the interchange.
- (46) "Interchange management plan" means a plan similar in nature to an access control plan but limited to the immediate influence area of an interchange for the protection of its functional integrity.
- (47) "Issuing authority" means the entity which issues access permits and includes the board of county commissioners, the governing body of a municipality, and the department of transportation. [§ 43-2-147(8)(e), C.R.S.]
- (48) "Lane" means the portion of a roadway for the movement of a single line of vehicles. [§ 42-1-102(46), C.R.S.]

- (49) "Level of service" means a measure describing the operational conditions within a stream of traffic. The measure uses factors including speed, travel time, ability to maneuver, traffic interruptions, safety, waiting time periods (delay), and driver comfort and convenience.
- (50) "Local government" means the board of county commissioners if the highway section is located in an unincorporated area of a county or the governing body of the municipality if the highway section is located within an incorporated municipality.
- (51) "Local road" means a county road, as provided in sections 43-2-108 and 43-2-109. [§ 43-2-147(8)(f), C.R.S.]
- (52) "Local street" means a municipal street, as provided in sections 43-2-123 and 43-2-124. [§ 43-2-147(8)(f), C.R.S.]
- (53) "Median" means that portion of a highway separating the opposing traffic flows.
- (54) "MPH" means a rate of speed measured in miles traveled per hour.
- (55) "MPO" means a metropolitan planning organization as defined under the federal "Urban Mass Transportation Act of 1964" (Public Law 88-365, 49 U.S.C. 1601 et seq.).
- (56) "M.U.T.C.D." means the Manual on Uniform Traffic Control Devices and the Colorado supplement thereto.
- (57) "National Highway System", (NHS) means a portion of highway that has been designated as a part of the National Highway System in accordance with 23 United States Code, § 103(b).
- (58) "Non-use" means the absence or lack of any significant purposeful and ongoing physical or economic activity on, or use of, a property or access by the owner or authorized persons, taking into account the nature, circumstances, zoning, and past use of the property or access. Non-use includes the occasional and inconsequential presence upon such property or access when not associated with any significant purposeful and ongoing physical or economic activity on, or use of, the property or access.
- (59) "Peak Hour Volume" means, only for the purposes of the Code, the same as design hour volume (DHV).
- (60) "Permittee(s)" means any person, unit of government, public agency or any other entity that owns a fee interest in the property served, to whom an access permit is issued. The permittee is responsible for fulfilling all the terms and conditions of the permit.
- (61) "Person" means every natural person, corporation, association, firm, partnership, limited liability company or other entity.
- (62) "Potential for signalization" means a determination, using a 20-year projection, that indicates the access volumes would be within 25 percent of those required for a M.U.T.C.D. Traffic Signal Volume Warrant.
- (63) "Prima facie" means a fact presumed to be true unless disproved by some evidence to the contrary (Latin).
- (64) "Property owner" means a person who holds a fee simple title to the property for which access to the state highway is being sought.

- (65) "Public Way" means a highway, street or road, open for use by the general public and under the control or jurisdiction of the appropriate local authority or Department and includes private roads open to the public.
- (66) "Right-of-Way" means the entire width between the boundary lines of every way publicly maintained when any part thereof is open to the use of the public for purposes of vehicular travel or the entire width of every way declared to be a public highway by any law of this state.
- (67) "Roadside" means that area between the outside shoulder edge of the roadway and the right-of-way limits. May also mean the area between two roadways when the roadways are well separated and landscaped such as a freeway median area.
- (68) "Roadway" means that portion of a highway improved, designed, or ordinarily used for vehicular travel, exclusive of the sidewalk, berm, or shoulder even though such sidewalk, berm, or shoulder is used by persons riding bicycles or other human-powered vehicles and exclusive of that portion of a highway designated for exclusive use as a bicycle path or reserved for the exclusive use of bicycles, human-powered vehicles, or pedestrians. In the event that a highway includes two or more separate roadways, "roadway" refers to any such roadway separately but not to all such roadways collectively. [§42-1-102(85), C.R.S.]
- (69) "Sight distance" means the distance visible to the driver of a passenger vehicle measured along the normal travel path of a roadway from a designated location and to a specified height above the roadway when the view is unobstructed by traffic.
- (70) "Signal" means a traffic control signal.
- (71) "Signalization" means a traffic control signal. When used in a predictive (future) sense, it means an access (intersection) location that is predicted to meet any of the warrants for a traffic signal as defined by the M.U.T.C.D.
- (72) "Signal progression" means the progressive movement of traffic, at a planned rate of speed without stopping, through adjacent signalized locations within a traffic control system.
- (73) "Single unit vehicle" means a single frame vehicle, longer than a passenger car, as described dimensionally by American Association of State Highway and Transportation Officials as a single unit design vehicle. Generally, these are motorized vehicles including delivery trucks, haul vehicles, camping and recreational vehicles, and motor homes, having a single frame and an overall length of greater than 19 feet with two or three axles.
- (74) "Slope" means the relative steepness of the terrain expressed as a ratio or percentage. Slopes may be categorized as positive or negative and as parallel, cross or side slopes in relation to the direction of traffic.
- (75) "Speed change lane" means a separate lane for the purpose of enabling a vehicle entering or leaving a roadway to increase or decrease its speed to a rate at which it can more safely merge or diverge with through traffic. Acceleration and deceleration lanes are speed change lanes.
- (76) "State highway" means a highway that is a part of the state highway system under the jurisdiction of the Commission.
- (77) "State plan" means the comprehensive statewide transportation plan formed by the Commission pursuant to the provisions of section 43-1-1103 (5), C.R.S.
- (78) "Stopping sight distance" means the distance required by a driver of a vehicle, traveling at a given speed, to bring the vehicle to a stop after an object on the roadway becomes visible. It includes

the distance traveled during driver perception and reaction times and the vehicle braking distance.

- (79) "Storage lane length" means the length of a portion of an auxiliary lane required to store the maximum number of vehicles likely to accumulate in the lane during a peak hour period.
- (80) "Subdivide" means to divide land into two or more smaller lots, tracts or parcels of land.
- (81) "Subdivision" means a tract of land which has been subdivided in accordance with the laws of the state usually with appropriate streets, dedications and other facilities for the development or sale of industrial, commercial or residential land.
- (82) "Taper" means the widening of pavement to allow the redirection and transition of vehicles around or into an auxiliary lane. There are two different types of tapers. Redirect tapers necessary for the redirection of vehicles along the traveled way (table 4-9), and transition tapers for auxiliary lanes (table 4-6) that allow the turning vehicle to transition from or to the traveled way, to or from an auxiliary lane.
- (83) "Time-space diagram" means a chart on which the distance between signals and signal timing is plotted against time. The chart indicates signal progression, efficiency, bandwidth and speed of traffic. Efficiency is the width of the through band expressed as a fraction of the entire signal cycle. A 50% efficiency means that 30 seconds of a 60 second signal cycle is devoted to the movement of through traffic.
- (84) "TPR" means Transportation Planning Region. A region of the state established pursuant to section 43-1-1103 (5), C.R.S. Each TPR has a Regional Planning Commission formed under the provisions of section 30-28-105, or 43-1-1103, C.R.S.
- (85) "Traversable slope" means a slope from which a motorist will be unlikely to steer back to the roadway but may be able to slow and stop safely.
- (86) "Traversable median" means a median that by its design does not physically discourage or prevent vehicles from entering upon or crossing over it. Such medians include painted medians and continuous two-way left-turn lanes.
- (87) "Traveled way" means that portion of roadway for the through movement of vehicles, exclusive of shoulders, gutters, and auxiliary lanes.
- (88) "Trip" means a single or one-direction vehicle movement with either the origin or the destination inside a study area. A vehicle leaving the highway and entering a property is one trip. Later when the vehicle leaves the property it is a second trip.
- (89) "Under construction" means a sustained effort reflected by construction activity likely to result in the completion of access improvements in a timely manner.
- (90) "VPH" means the number of vehicles per hour and usually is referring to the vehicles in a peak hour unless otherwise modified by the text.
- (91) "Warrant(s)" means the criteria by which the need for a safety treatment or highway improvement can be determined.
- (92) "Working day" means any day that the permittee can perform a normal day of work exclusive of delays which result from inclement weather, labor disputes and material shortages. It does not include weekends and legal holidays.

1.6 Computation of Time

All time periods referred to and allowed by these rules and the Act shall be computed in accordance with Colorado Rules of Civil Procedure, Rule 6(a).

1.7 Incorporation by Reference

- (1) The following nationally recognized standard is hereby incorporated by reference into the Code: *Trip Generation*, Sixth edition, Institute of Transportation Engineers, Washington, D.C. 1997. [525 School Street, S.W., Suite 410, Washington D.C. 20024-2729, phone (202)554-8050]. Copies of the incorporated material is available for public inspection during regular business hours from the Access Program Administrator, Department of Transportation, Transportation Safety and Traffic Engineering Branch, 4201 East Arkansas Avenue, Denver, Colorado, 80222-3400. Information concerning how the incorporated material may be obtained or examined will be provided by the Access Program Administrator upon request. Later editions of "Trip Generation" may not be relied upon. The incorporated material may be examined at any state publication depository library.

Section Two Administration

2.1 Purpose

- (1) This section provides the administrative procedures and related information and requirements for the implementation of the Code. Additionally, the provisions of the State Administrative Procedure Act, §24-4-101 et seq. (C.R.S.), apply to the extent they are applicable.

2.2 Access Category Determinations

(1) The Commission Shall Maintain an Access Category Assignment Schedule

- (a) In support of the Code, the Commission shall maintain by rule an access category assignment schedule for the state highway system. The Commission shall assign to each state highway section or segment of highway an access category from Section Three of the Code. The assignment of access categories provides the functional basis for acting on an access permit request.
- (b) In deliberations regarding selection of access category assignments, the Commission may consider adopted administrative and functional classifications, existing and projected traffic volumes, current and future highway capacity and levels of service, current and predicted levels of highway safety, adopted state and local transportation plans and needs, the character of lands adjoining the highway, adopted local land use plans and zoning, the availability of vehicular access from local streets and roads rather than a state highway, and reasonable access provided by municipal streets and county roads, and if provided, the initial recommendation of the local authority.
- (c) The State Highway Access Category Assignment Schedule published in May 1992, 2 CCR 601-1a, shall be the category listing reference basis for access permit determinations until new access category assignments, consistent with Section Three of the Code, are adopted by the Commission in accordance with 2.2(2). This 1998 Code changes the titles of Section Three access categories and the descriptions of the categories in comparison to the 1985 edition of the Code. The 1992 State Highway Access Category Assignment Schedule, 2 CCR 601-1a, uses a One through Five category title classification system. In regards to referencing the 1992, 2 CCR 601-1a, all 1992 category assignments titled "1" shall use 1998 Code category F-W. All 1992 category assignments titled "2" shall use 1998 Code category E-X. All 1992 category assignments titled "3" shall use 1998 Code category R-A. All 1992 category assignments titled "4" shall use 1998 Code category NR-B. All 1992 category assignments titled "5" shall use 1998 Code category F-R.

(2) The Initial Assignment Process - Category Determinations

- (a) The Department will promptly begin a recategorization process for all state highways in accordance with section 2.2(2) following the effective date of this 1998 Code. The procedures to accomplish access category assignments shall be as described in this subsection 2.2(2). Once a new category is adopted for a highway section based on subsection 2.2(2) by Commission action and becomes effective, any subsequent access category revisions for that section shall be in accordance with subsection 2.2(3).
- (b) There is no minimum or maximum criteria for the length of a category assignment. Assignment boundaries may occur as frequently as necessary in consideration of the assignment criteria contained in 2.2(1)(b). Assignment boundaries should be logical and identifiable, and highway continuity should be maintained to the extent reasonable.
- (c) By written inquiry, the Department will determine which local authorities wish to make the initial recommendations for access category assignment in their jurisdiction. The Department will provide training and information as necessary to assist those jurisdictions that wish to make the initial recommendations. The Department will provide each local jurisdiction with a list of state highways within their boundaries along with their current access category assignments.
- (d) For all those local authorities not choosing to select their own initial recommendations, or who do not respond in 30 days from the inquiry, the Department shall select the initial category assignment recommendations. Where the Department makes the initial selection, the Department shall provide the draft selection and reasonable explanation to the local authority and the MPO/TPR for their review and comment. Written comments received from the local authority or any other source shall be a part of the record with the exception of documents protected by the attorney/client privilege. All written correspondence external to the Department and completed internal Department documents shall be considered a part of the rule making record.
- (e) The appropriate local authority choosing to make the first initial recommendations must submit recommendations on all state highways in their jurisdictions to the Department and the MPO/TPR within 90 days of the effective date of the 1998 Code. Upon receipt of the local jurisdiction's category recommendations, the Department will review the local assignment requests. Where there is a difference of opinion regarding the recommendation of category assignment, the Department and the local authority shall discuss the issues and attempt to arrive at mutually agreeable assignment recommendations. The appropriate MPO or TPR may participate in discussing category assignment recommendations. Where adjacent municipalities share common state highway boundaries, the recommendation of both shall be considered.
- (f) For those highway sections where mutually agreeable assignment recommendations cannot be made, those sections shall be separately itemized and numbered and presented at a rule making hearing as a separate category document. The Department shall provide a discussion as to why the Department disagrees with the local recommendation. When a consensus is not reached between the local jurisdiction, the MPO/TPR, and the Department, then the Department must inform the local jurisdiction and the MPO/TPR in writing of the Department category recommendation prior to any action taken by the Commission.
- (g) Local category recommendations shall be made based on the criteria of 2.2(1)(b), and may include the existing conditions of the highway and the community's vision of what the highway should be. MPO's and TPR's may provide review and comment.
- (h) Local jurisdiction category recommendations and Department category recommendations will be given to the Commission for a final category determination at a public rule making hearing. Local jurisdictions and others will have the opportunity to present their recommendations in public testimony before the Commission. The determination of the Commission will be by rule making and considered the final access category assignment.

(3) Subsequent Changes in Assigned Categories

- (a) The appropriate local authority acting by resolution; the MPO or TPR with the approval of the affected local authority; or the Department; may submit to the Commission requests for changes in the adopted access category schedule for sections of state highway within their jurisdiction. All requests shall include information pertaining to the criteria itemized in section 2.2(1)(b), as well as an explanation of the necessity of the requested change, and how the requested change is consistent with the purposes of the Act and the standards of the Code. The Department shall review and provide a recommendation to the Commission on each request. If the Department is seeking a change in access category, or making a recommendation for assigned category for a new or reconstructed section of highway, the appropriate local authority and the MPO/TPR shall be notified of the requested changes at least 60 days prior to Commission action. The appropriate local authority and the appropriate MPO/TPR will be provided with a copy of all pertinent documents 30 days prior to Commission action. All written comments shall be a part of the record.
- (b) The Commission, in accordance with § 24-4-103, C.R.S., shall act upon pending category change requests no less than four times a year, generally being the first, fourth, seventh and tenth months of the calendar year. A request must be received for processing and analysis a minimum of 90 days preceding the Commission consideration.

2.3 Permit Application Process, Obtaining a Permit

(1) Determining the Issuing Authority

- (a) The Act provides to each appropriate local authority the authority to issue driveway permits to state highways within its jurisdiction. Each driveway permit must receive the written approval of the Department to be valid. The local authority may request that the Department administer or assist in the administration of driveway permits. Such authorization may be changed by the local authority at any time by written notification to the Department. Changes in authorization shall take effect upon receipt of written notice by the Department. If the local authority requests that the Department process the access permit application and requires local authority approval prior to final action, this shall constitute Department assistance, not administration, and the local authority shall remain the issuing authority.
- (b) Persons wishing to apply for access to a state highway should contact their appropriate local authority or a Department office in their region to determine who is responsible for processing permit applications in their area. Regional Department offices are located in Aurora, Denver, Durango, Grand Junction, Greeley, and Pueblo. Application packages including application form No. 137 may be obtained from any issuing authority.

(2) Pre-application Meetings

- (a) Prior to submitting a formal application, interested parties may request a pre-application conference with the issuing authority. If the Department is the issuing authority, the local authority should be invited. If the local authority is the issuing authority, the Department should be invited. The purpose of such a conference shall be to review the preliminary proposal and to allow reaction and suggestions from the issuing authority prior to formal application. Interested parties should provide preliminary maps, plans and documents to illustrate to the extent possible, the site, ownerships, size and type of land use, estimated traffic volumes and vehicle types generated, adjacent public roads, existing and available access points, and other adjacent accesses. At the conference, participants will discuss Code requirements, site specific conditions, various options for access location and design, and those items that should be submitted with the permit application.

- (b) If a pre-application conference is held, an application can be submitted anytime after the pre-application conference. An application may be submitted at the end of the pre-application conference.

(3) Preparing an Application

- (a) To obtain permission to construct, modify, relocate or close a vehicular access, where such work will be within highway right-of-way, a state highway access permit is required. To obtain permission, a complete application must be submitted to the issuing authority and a permit issued. Construction may not begin until a Notice to Proceed is approved. Application packages may be obtained from the issuing authority. Incomplete applications may be rejected by the Department or issuing authority.
- (b) Applications for access shall include a completed access permit application, Department form No. 137 and any required attachments reasonably necessary to review and assess the application or complete the permit. If a pre-application conference was held, the application will consist of the attachments requested at the pre-application conference. Attachments necessary may include plans, maps, traffic studies, surveys, deeds, agreements, documents, data, and location of any significant utilities to be moved. The scale, location and anticipated impacts of the access proposal will determine the scope of the attachments necessary in the application. The applicant may be required to submit information needed to evaluate the impacts of the proposed access on the general street system (which includes the state highway). All such submittals become the property of the issuing authority. Items without relevance on the approval or denial of the application or completion of the permit will not be requested. If the applicant is other than the fee surface rights owner of the property to be served, then the applicant must include sufficient evidence of concurrence or knowledge in the application by the fee rights owner and proof of development rights, (ie. option to buy, federal use permit). Complete names, addresses and telephone numbers of the property owner(s), the applicant(s), and primary contact person, shall be given on the application along with the expected dates of construction and commencement of use of the access. When the owner or applicant is a company, corporation or government agency, the office, title and the name of the responsible officer will be provided. A corporation must be licensed to do business in Colorado. Intentional misrepresentation of existing or future conditions or of information requested for the application for the purposes of getting a more favorable determination, shall be considered sufficient grounds for application rejection, permit denial or revocation of a permit.
- (c) If an applicant wishes to seek a waiver from the design standards of the Code, a request may be submitted as an attachment to the permit application form. An original 2 part Department form No. 112 shall be used. See subsection 4.12 on design waivers.
- (d) The property owner or authorized representative served by a lawful access may make physical improvements to an access with the permission of the issuing authority and the Department. The applicant shall make the request on standard permit application forms and may specify that the request is for improvements according to this subsection. This subsection does not apply when there is or will be a change in historical grandfathered use or access use in accordance with Code section 2.6. Processing of the application shall be the same as provided in Code section 2.3 except the Department and issuing authority may only take action on the request for improvement. Denial of the application for improvements does not constitute revocation of the existing access authorization. If approved for improvements, the permit need not require full Code design compliance, so long as access is improved above current conditions and there is no deterioration in safety or operation of the highway. Denial of an application to enlarge, relocate, or modify an existing lawful access shall in no way impair the permit for or right to the existing access for its legal historical use.
- (e) When a permit is authorized, the permittee is responsible to pay any permit fees established pursuant to section 43-2-147(5)(b), C.R.S. If the issuing authority is a local authority, the fee amount is set

by the local authority. If the issuing authority is the Department, the fees are established by the Executive Director of the Department.

(4) Sources, Data and Information Requirements

- (a) Applications shall not be inconsistent with the data and information requirements of this subsection. The seal of a Colorado registered professional engineer is required on all plans, traffic studies, engineering analyses, reports and drainage plans submitted to an issuing authority or the Department, and for any proposed access and construction plans involving changes to the roadway or for the access if the volume of the development is predicted to exceed 100 vehicles per day.
- (b) *Trip Generation*, Sixth edition, The Institute of Transportation Engineers, Washington D.C., 1997 shall be used as a reference in estimating DHV or peak hour traffic volume values of an access where required by the Code. Later revisions to this manual may not be relied upon. In the absence of a traffic analysis by a traffic engineer or actual collected data, a reasonable estimation of trip generation using the ITE Trip Generation Manual shall be considered prima facie evidence when estimating traffic volumes for existing access. If local or special generation rates are used, all documentation for rate development shall be submitted. For mixed use developments, internal trip reductions will not exceed two percent for the AM peak or eight percent for PM peaks unless clearly justified and documented by actual studies. The issuing authority may assist any applicant requesting traffic estimates for the purpose of obtaining a highway access permit.
- (c) For the purposes of this section the DHV for the access location may be considered synonymous with the term "peak hour volume" often used for traffic analysis. DHV calculations are preferred for design purposes and shall be used when required by the issuing authority or the Department.
- (d) The DHV or peak hour traffic volume estimates for any access shall be based upon the anticipated total build out of the development to be served and a twenty year projection for highway volumes. In the case of a public access, a reasonable projection of the twentieth year access volume shall be made based upon predicted growth, zoning and any comprehensive plan. In urbanized or urbanizing areas, volume generation analysis shall include the anticipated full build out of the study area to a one-mile radius. A larger area may be requested by the issuing authority if specific reasons are provided such as in developing rural areas and relative to interchanges. Estimates of traffic volumes shall be based upon average weekday traffic at locations where weekday employment predominates. Locations of retail development shall also include weekend traffic volumes. The analytical approach shall include the highest peak hour volume within the entire day for each turning movement.
- (e) Unless specifically noted, all criteria in the Code are based on automobile operations and performance. To allow for the impact of larger trucks, buses and recreational vehicles, "passenger car equivalents" shall be determined. A passenger car equivalent of 3 for each bus and all trucks and combinations of 40 feet in length or longer, or a passenger car equivalent of 2 for each vehicle or combination at or over 20 feet in length but less than 40 feet shall be used for these purposes.
- (f) Speed, as used in this section, refers to the posted legal speed limit at the access location at the time of permit approval. A higher speed for access design shall be used if the section of highway is presently being redesigned or reconstructed to a higher speed or an approved access control plan requires a higher speed. Where a traffic signal will be installed as part of the access construction, the access design and the anticipated posted speed limit after signal installation may be used for the overall access design at the discretion of the Department.
- (g) A reasonable trip distribution estimate should be provided based on the type of proposed development, competing developments (if applicable), the size of the proposed development, surrounding land uses and population, and the conditions of the surrounding street system. If the

applicant does not provide a distribution estimate, the distribution may be estimated by the Department or issuing authority. If no other estimate is made, a full movement access shall be considered to have 40 percent of ingressing vehicles making a left turn and 60 percent ingressing vehicles making a right turn on an average day.

(5) Traffic Impact Studies

- (a) When the land use will generate a DHV of 100 vehicles or more, or when considered necessary or desirable by the issuing authority or Department for exceptional reasons, the applicant shall provide a traffic impact study. The scope of the study shall be commensurate with the scale and scope of probable operational and safety impacts to the general street system.
- (b) When a traffic impact study is required, the study shall be completed and sealed by a Colorado registered professional engineer. Selected items from the following list may be excluded if not applicable to the situation and exclusion is specifically authorized by the issuing authority. The contents and extent of a traffic impact study depend on the location and size of the proposed development and the conditions prevailing in the surrounding area. Larger developments proposed in congested areas obviously require more extensive traffic analysis, whereas smaller sites may only require a minimal analysis of traffic on site and at immediately adjacent intersections. In determining how large a study area to include, a general guideline is to carry the analysis out at least as far as those areas where newly generated site traffic represents 5 percent or more of roadway's peak hour capacity. Where site generated traffic will be less than 5 percent of the roadway capacity, the intersections adjacent to the site should, at a minimum, be analyzed. The study area boundaries may also be influenced by impacts other than pure capacity relationships such as neighborhood short cuts, traffic noise and hours of operation.
- (c) The study shall use the following standards, and guidance, and provide the following information as applicable or as requested by the issuing authority. Additional information and additional analysis based upon other factors and standards may be included if the applicant desires:
 - (1) a scaled map of the vicinity showing all roadways and highways adjacent to the site, a scaled map of the study area including land uses, and a map of the immediate access area, a plan showing on-site anticipated vehicular circulation patterns
 - (2) map identification and textual consideration of all access that are existing and possible future access locations including signal locations for at least one-half mile in each direction along the highway as well as all potential roadway and signal improvements
 - (3) evaluation of current daily and peak hour traffic data and 20th year projections including turning movements at all intersections and any key year midpoints assuming a build out of the study area based upon zoning, comprehensive plans and growth estimates
 - (4) an evaluation of the level of service and capacity for all design and traffic operation elements including mainline roadway and affected intersections
 - (5) where applicable, an analysis of the clear zone, and the horizontal and vertical sight distances
 - (6) accurate and understandable diagrams
 - (7) all assumptions and adjustment factors
 - (8) an analysis of all reasonable alternatives including no build or no direct highway access alternatives

- (9) current and projected arterial travel speed, travel time, and delay time within the study area that will be impacted by the access proposal
- (10) site traffic generation rate estimates and resulting trip generation distribution and assignments
- (11) analysis of queue lengths for all turn lanes affected to the 20th year
- (12) a safety analysis including conflict points, turning movements and three years of accident history
- (13) a conceptual design showing all geometric elements and their approximate dimensions with analysis of any element of the access that will be below Code standards
- (14) sources of information, data and references
- (15) the existence of any current traffic problems in the local area such as a high accident location, confusing intersection, or an intersection in need of a traffic signal
- (16) the current or projected level of service of the roadway system adjacent to the development, which will be significantly affected
- (17) the sensitivity of the adjacent neighborhoods or other areas that may be perceived as impacted
- (18) the proximity of site driveways to the other access points or intersections
- (19) the ability of the adjacent existing or planned roadway system to handle increased traffic, or the feasibility of improving the roadway system to handle increased traffic
- (20) other specific problems or deficiencies that may be affected by the proposed development or affect the ability of the development to be satisfactorily accommodated.

If the access is proposed to have a traffic signal, or will necessitate modifications to a traffic signal, the following additional analysis are required:

- (21) an intersection capacity operation analysis for all signals included in the progression analysis and providing complete input and output reports, data and assumptions
- (22) the signal timings, phasing and data used in each analysis shall be consistent
- (23) highway traffic signal progression analysis including progression bandwidth, efficiency and level of service determinations, assumptions and data with complete input and output menu reports provided and including all existing and anticipated future signals within 1 mile of the proposed access
- (24) a signal cycle length of between 60 and 120 seconds and consistent with the existing corridor signal operation and function, shall be used for the analysis or as determined by the Department
- (25) analysis will use the posted speed limit(s) but may submit an additional analysis if it can be shown that a different speed is more efficient for capacity, highway delay and travel time
- (26) the highway bandwidth used shall be consistent with the requirements of the assigned access category

(27) signal phasing will normally assume lead phasing. Lag phasing may not be included unless specifically authorized

(28) the green time allowed for the cross street shall be no less than the time necessary to accommodate pedestrian movement

(29) analysis of storage queue lengths for auxiliary lanes at signalized intersections within the immediate study area.

(6) Submitting an Application When the Department is the Issuing Authority

(a) When the issuing authority is the Department, those persons seeking an access permit shall submit two complete applications to the appropriate region office of the Department. One copy of the application may be submitted if authorized by the Department. Incomplete applications may be rejected by the Department.

(b) A 45 day review period begins upon receipt of an access application including the completed application form and any necessary attachments at the region offices of the Department. The Department shall date and initial or stamp the original application form with the date of receipt. An application is presumed to be considered complete unless the Department determines it is not and provides that determination in writing. If an application is determined to be incomplete in the first 20 days, the review period ends.

(c) An application will receive a preliminary review within twenty days to determine if it is complete and sufficient. The Department will promptly transmit written notice to the applicant if the application is not complete and sufficient for review. The notice will include any outstanding items, issues or concerns, and will outline within that notice the access, if any, the Department would consider given the available information. Failure of the Department to comply with the preliminary review periods does not preclude the Department from denying any application.

(d) Subsequent to the 20 day period, if necessary information is later determined to be missing, the Department may deny the permit on grounds of insufficient information, and incomplete application unless the applicant withdraws the application. The denial shall provide an explanation as to the necessary and missing items and the reasons why the items are considered necessary.

(e) Upon receipt of the Department's letter requesting more information, the applicant may provide additional data and information as appropriate, or withdraw the application. If the applicant provides additional information as requested, the 45 day period starts over. If the applicant withdraws the application, then later resubmits an amended application, the same procedures as for initial submittal application shall be used.

(7) Processing of an Access Permit Application When the Department is the Issuing Authority

(a) Upon receipt of the application and any required attachments, the Department shall use the Code, the Act and any other applicable state and federal laws for evaluating and acting on the application. The Department may grant the access as proposed, require layout and location modifications as it considers appropriate, restrict one or more turning movements as necessary to reduce traffic and safety impacts, or deny the access, all as determined by the standards of the Code. Any access permit prepared by the Department shall conform to all sections of the Code. Waiver procedures may be considered for any design standard of the Code not applicable or feasible given proposed access site specific physical and traffic operation conditions.

(b) If the proposed access cannot meet the requirements or standards of the Code including consideration of appropriate design waiver criteria, or other applicable laws, the application shall

be denied. If the Department denies the permit application, the Department shall provide the applicant a copy of the permit application form 137 marked "denied" and a written explanation of the decision.

- (c) Any appeals of Department action shall be made pursuant to the subsection 2.9.
- (d) If the Department fails to act on a complete application within 45 days from the date of receipt of the application, the permit shall be considered approved and an appropriate permit issued by the Department in accordance with the design and construction standards of the Code.
- (e) If the Department approves the access proposal, a permit will be prepared and transmitted to the applicant for signature. This transmittal constitutes action on the permit as required by section 43-2-147(5)(a), C.R.S. It is the responsibility of the applicant to obtain the signature of the permittee(s). The permittee(s) shall sign the permit if the terms and conditions are acceptable and return the entire permit with any required permit fee to the Department at the address noted. In accepting the permit, the permittee agrees to all terms and conditions of the permit. If the Department has not received the signed copy and fee payment, if any, from the applicant within 60 days of the date of transmittal, the permit shall be deemed withdrawn. After receiving the signed permit and fee payment, if any, the Department shall mark the permit paid, sign the permit, and return a copy to the applicant. If the permittee(s) do not agree to all the terms and conditions of the permit, the permit shall be considered denied. Each approved permit shall have a unique permit number assigned by the Department.

(8) Submitting an Application When the Local Authority is the Issuing Authority

- (a) When the local authority is the issuing authority, those persons seeking an access permit shall submit at least two complete applications to the appropriate office of the local issuing authority. The local issuing authority may request additional application copies from the applicant. Incomplete applications may be rejected by the local issuing authority.
- (b) A 45 day review period begins upon receipt of an access application including the completed application form and any necessary attachments at the permit offices of the local issuing authority. The local issuing authority shall date and initial or stamp the original application form with the date of receipt. An application is presumed to be considered complete unless the local issuing authority determines it is not and provides that determination in writing. If an application is determined to be incomplete in the first 20 days, the review period ends.
- (c) An application will receive a preliminary review within twenty days to determine if it is complete and sufficient. The local issuing authority will promptly transmit written notice to the applicant if the application is not complete and sufficient for review. The notice will include any outstanding items, issues or concerns, and will outline within that notice the access, if any, the local issuing authority would consider given the available information. Failure of the local issuing authority to comply with the preliminary review periods does not preclude the local issuing authority from denying any application.
- (d) Subsequent to the 20 day period, if necessary information is later determined to be missing, the issuing authority may deny the permit on grounds of insufficient information, and incomplete application unless the applicant withdraws the application. The denial shall provide an explanation as to the necessary and missing items and the reasons why the items are considered necessary.
- (e) Upon receipt of the local issuing authority's letter requesting more information, the applicant may provide additional data and information as appropriate, or withdraw the application. If the applicant provides additional information as requested, the 45 day period starts over. If the

applicant withdraws the application, then later resubmits an amended application, the same procedures as for initial submittal application shall be used.

(9) Processing of an Access Permit Application When the Local Authority is the Issuing Authority

- (a) Upon receipt of the application and any required attachments, the local issuing authority shall use the Code, the Act and any other applicable state and federal laws for evaluating and acting on the application. The local issuing authority may grant the access as proposed, require layout and location modifications as it considers appropriate, restrict one or more turning movements as necessary to reduce traffic and safety impacts, or deny the access, all as determined by the standards of the Code. Any access permit prepared by the local issuing authority shall be in conformance with the Code. Waiver procedures may be considered for any design standard of the Code not applicable or feasible given proposed access site specific physical and traffic operation conditions. The issuing authority shall complete its review and take final action to approve or deny the application within 45 days of the date of acceptance.
- (b) If the proposed access cannot meet the requirements or standards of the Code including consideration of appropriate design waiver criteria, or other applicable laws, the application shall be denied. If the local issuing authority denies the permit application, the local issuing authority shall provide the applicant and the Department a copy of the permit application form 137 marked "denied" and a written explanation of the decision. The Department may not reverse the denial decision by the local issuing authority. Any appeal by the applicant of local action shall be to the local issuing authority and shall be consistent with the appeal procedures of that issuing authority. The local issuing authority shall notify the Department of appeals made of local issuing authority actions on state highway access permits and applications.
- (c) If the local issuing authority has or will fail to act on a complete application within 45 days from the date of receipt of the application, the Department shall be notified. If the local issuing authority has not taken final action within 45 days from the date of application acceptance by the local issuing authority, the Department is authorized and shall take final action on the application within 20 days as required by the Act. Transmittal of the permit application, unsigned by the appropriate local issuing authority, for the purpose of obtaining the Department's comments prior to local approval, does not constitute the initiation of the 20 day review period.
- (d) If the local issuing authority approves the application, it shall prepare a permit which shall include all terms and conditions necessary to meet the requirements of the Code. The issuing authority shall sign and transmit the permit with all attachments and pertinent information to the appropriate regional office of the Department. This transmittal constitutes action on the permit as required by section 43-2-147(5)(a), C.R.S.
- (e) After receiving a permit approved by a local issuing authority, the Department shall review the permit for compliance with the Code, the Act and other state or federal law which may be applicable. Prior to Department action, the Department may, in consultation with the local issuing authority, revise the permit as necessary to add terms, conditions, standards and specifications. If the Department determines that the permit does not meet Code requirements, or waiver criteria, or applicable laws, the Department shall deny the permit. The Department shall provide both the applicant and the local issuing authority a written explanation for the decision. Any appeals of Department action shall be made pursuant to the subsection on appeals.
- (f) If the Department fails to act within 20 days from receipt of the transmitted permit from a local issuing authority, or within 20 days after a local issuing authority should have acted, whichever is the lesser, the permit shall be considered approved and an appropriate permit issued in accordance with the design and construction standards of the Code.
- (g) If the Department approves the access permit it will be transmitted to the applicant for signature. This transmittal constitutes action on the permit as required by section 43-2-147(5)(a), C.R.S. It is the

responsibility of the applicant to obtain the signature of the permittee(s). The permittee(s) shall sign the permit if the terms and conditions are acceptable and return the entire permit with any required local issuing authority permit fee to the Department at the address noted. In accepting the permit, the permittee agrees to all terms and conditions of the permit. If the Department has not received the signed copy and fee payment, if any, from the applicant within 60 days of the date of transmittal, the permit may be deemed withdrawn. After receiving the signed permit and fee payment, if any, the Department shall mark the permit paid, sign the permit, and return a copy to the applicant and to the local issuing authority along with any collected fees. If the permittee(s) do not agree to all the terms and conditions of the permit, the permit shall be considered denied. Each approved permit shall have a unique permit number assigned by the Department.

(10) Contents of an Access Permit

- (a) The terms and conditions of a completed access permit shall address all of the access conditions, including, but not necessarily limited to the following:
1. Type and configuration of the access (i.e., signal, 3/4, right/right, etc.)
 2. The access location description will be written as exactly as the circumstances require — that is, it could be determined as “directly across” from an existing access, or “within x feet” of an existing access or intersection, or “not less than x feet” from an existing access or intersection, or any other means to make clear the access location parameters. The Department Reference Point will be noted to the nearest 100th of a mile in the upper right hand corner of the permit.
 3. Whether acceleration or deceleration lanes are required and generally what other physical improvements may be required at the time of request for the Notice to Proceed.
 4. If known, whether the approved access may include or necessitate any design waivers.
 5. Limiting conditions, if any, including turn limitations, future limitations, and restrictions and any terms and conditions that would require the access approval to be revisited at a later date.
 6. What is necessary for completion and approval for the issuance of a Notice to Proceed.

(11) General Permit Issues

- (a) When the Code or related official forms require the signature of the permittee(s) or applicant, such signatures must be that of the specific individual, or if a corporation or partnership or other entity, the duly authorized officer or agent of the corporation or partnership or other entity. The name of the corporation, partnership or entity shall be included with the signature.
- (b) The issue date of the permit is the date the Department representative signs the permit. Only the Chief Engineer, the appropriate Region Transportation Director, or other specifically authorized Department staff may authorize access permits for the Department.
- (c) The granting of an access permit conveys no rights, title or interest in state highway rights-of-way to the permit holder or property served. A permit for direct access to a state highway does not entitle the permit holder to control or have any rights or interests in any portion of the design, specifications or operation of the highway or roadway, including those portions of the highway built pursuant to the terms and conditions of the permit.
- (d) A permit shall be considered expired if the access is not under construction within one year of the permit issue date or before the expiration of any authorized extension. When the permittee is

unable to commence construction within one year after the permit issue date, the permittee may request a one year extension from the issuing authority. No more than two one-year extensions may be granted under any circumstances. If the access is not under construction within three years from date of issue the permit will be considered expired. Any request for an extension must be in writing and submitted to the issuing authority before the permit expires. The request should state the reasons why the extension is necessary, when construction is anticipated, and include a copy of page 1 (face of permit) of the access permit. Extension approvals shall be in writing. The local issuing authority shall obtain the concurrence of the Department prior to the approval of an extension, and shall notify the Department of all denied extensions within ten days. Any person wishing to reestablish an access permit that has expired may begin again with the application procedures. An approved Notice to Proceed, automatically renews the access permit for the period of the Notice to Proceed.

- (e) For any permit involving changes in the roadway or structures, the Department or issuing authority may require the permittee to hire a Colorado registered professional engineer to inspect the access carefully and to affirm to the best of their knowledge and belief that the construction is in compliance with the permit specifications and to report any item which may not be in compliance or can't be determined to be in compliance, and the nature and scope of the item relative to compliance. The issuing authority and Department may require testing of materials. When so required, test results shall be provided to the Department or as specified on the permit.
- (f) The right-of-way necessary for state highway roadway improvements including travel lanes and auxiliary lanes shall be provided to the Department in accordance with paragraph (g). Unless otherwise determined by the Department, other non-roadway appurtenances such as curbs, sidewalks, shoulders, bike lanes, bike paths, drainage structures, ditches, landscaping, utilities, and traffic control devices, which are beyond the edge of the roadway, may be on permanent easements, or if in public ownership then by agreement, or conveyed to the Department in accordance with paragraph (g). If a permanent easement is provided, the easement must convey all rights of development, construction, control, maintenance, operation and may be subject to the police powers for state highway purposes and cannot be occupied in any manner by the fee simple owner without specific Department authorization. Where there is a permanent easement, the permittee is responsible for maintenance of all appurtenances in the permanent easement except traffic control devices. Section 43-2-135, C.R.S., 'division of authority over streets', applies. The Department shall provide the language for the permanent easement. Such language will be standardized. The Department cannot indemnify the underlying fee simple owner from any legal claims in the permanent easement area. The highway right-of-way boundary shall be considered the back of any permanent easement given to the Department for highway purposes.
- (g) Property required by the Department for permit related highway access improvements shall be conveyed without cost to the Department by dedication, or by a warranty deed or permanent easement as described above. All right, title and interests shall be conveyed. All current title policies must be provided and be acceptable to the Department. The owner must certify that the property is clean of contamination or indemnify the Department from any contamination responsibilities prior to conveyance. The Department may refuse to accept any property, including but not limited to that containing or suspected of containing hazardous substances, toxic wastes, or other contamination until such substances are removed and or the property is certified clean by the appropriate governmental entity, or the Colorado Department of Public Health and Environment, and if necessary, the Environmental Protection Agency. The Access is not considered complete until property is conveyed.
- (h) Where access improvements require the reconstruction of an existing roadway open to travel, the Department or local authority may require the permittee or permittee's contractor to post a bond, establish an escrow account, or in some other manner provide security to insure completion of the work within the highway. The security shall be sufficient to cover any repair or reconstruction of the access work area to a standard comparable with conditions prior to the initiation of access construction and to the extent necessary to ensure public safety as determined by the

Department. Where extensive reconstruction of the highway is necessary the Department may require the use of a Department prequalified contractor.

- (i) The permittee or contractor may be required to provide comprehensive general liability and property damage insurance naming the Department and the issuing authority (if applicable) as an additional insured party, in the amounts of not less than \$600,000 per occurrence and automobile liability insurance of \$600,000 combined single limit bodily injury and property damage for each accident, during the period of access construction. By accepting the permit, permittee agrees to save, indemnify, and hold harmless to the extent allowed by law, the issuing authority, the Department, its officers, and employees from suits, actions, claims of any type or character brought because of injuries or damage sustained by any person resulting from the permittee's use of the access permit during the construction of the access.
- (j) Upon request, the phasing of the installation of access design requirements may be allowed if the average (as defined by DHV analysis or equivalent) use of the access at any time does not exceed the constructed design and the Department or local authority is provided monetary or legal guarantees that access permit terms and conditions will be met prior to any use of the access exceeding the existing design of the access. The following items may be used in this regard: posting a bond, irrevocable letter of credit, certificates of deposit, inclusion in zoning ordinance, inclusion in subdivision plats or land use permit requirements, inclusion in the deeds to the properties involved and any other techniques as approved and accepted by the Department. All such arrangements shall be included as terms and conditions of the permit. The local authority or Department may record notices in the county records of such agreements to inform future property owners of potential liabilities and responsibilities. If the project is to be phased over time, the schedule, location and other details of each phase shall be provided by the permittee.

(12) Access Requests by Local Authorities

- (a) Requests by appropriate local authorities for new access or for the reconstruction of existing access to the state highway (such as county roads and municipal streets) shall be administered by the Department as provided in subsection 2.3(6) and (7), or by special written agreement or contract between the Department and the local authority. The local authority shall be considered the applicant. Access to subdivisions and other developments shall be processed in the same manner as a private access and applied for pursuant to subsection 2.3(6) or 2.3(8) until the access is constructed, completed, and accepted as a public access and public way by the appropriate local authority.
- (b) Where a private development accessing the roadway of an appropriate local authority necessitates access improvements where the local roadway connects to a state highway, the permittee may either be the local jurisdiction, the developer or a combination, at the discretion of the local authority.

2.4 Issuing a Notice to Proceed

- (1) The Notice to Proceed is not a license. It states that the permittee has met the pre-construction and permit submittal requirements and may now proceed with construction. When ready to begin construction, the applicant shall submit all permit required construction drawings, specifications and other required items, along with a copy of the access permit to the issuing authority and provide a copy to the Department if the Department is not the issuing authority. If the issuing authority is the local authority, the local authority may request the Department to handle all processing of the Notice to Proceed. The request shall be in writing. The Department shall provide a copy of the Notice to Proceed to the local authority.
- (2) The issuing authority or Department has seven days to determine if the submittal is complete for review or notify applicant of deficiencies. If complete, the submittals will be reviewed within thirty days and returned to the applicant with all required corrections identified. If certain submitted

items are found unacceptable, missing, or in need of correction, the applicant shall correct their submittals and resubmit the request for Notice to Proceed.

- (3) Upon resubmittal, the revised documents shall be reviewed within ten days. If the corrections made are satisfactory, the Notice to Proceed will be issued. If further corrections are necessary, the cycle of submittal, review and comment repeats itself until approval is granted and the Notice to Proceed is issued. If the applicant chooses not to request the Notice to Proceed, or chooses not to resubmit, the permit expires pursuant to subsection 2.3(11)(d).
- (4) When certain new technical issues arise during this review that may affect the access permit terms and conditions the Department and the issuing authority will determine whether the technical issues fall within the conditions or parameters stated within the access permit. If the documents are consistent with the access permit, the Notice to Proceed will be granted. If they do not, the access in question is subject to the following options:
 - a. The applicant may attempt to solve the technical issues within the terms and conditions outlined in the access permit.
 - b. The Department may grant a waiver to those standards.
 - c. All parties may agree upon a different access location, design or configuration and jointly amend the access permit and then proceed to issue the Notice to Proceed.
- (5) When necessary to amend a permit, and the permittee is agreeable and waives the right to an administrative hearing on the amendment, a letter detailing the amendment with reasons for the amendment shall be prepared. The letter of amendment requires the approval of the issuing authority, the Department and the permittee.
- (6) When a traffic control plan is required, such a plan must be consistent with the Department Standard Plans Manual for Maintenance and Signing or a specific plan prepared by an American Traffic Safety Services Association (ATSSA) or Colorado Contractors Association certified individual or sealed (stamped) by a Colorado registered professional engineer, consistent with the M.U.T.C.D. and be acceptable by the Department and the issuing authority prior to any construction within the right-of-way. The final traffic control plan must be submitted a minimum of three working days in advance of construction. If requested by the issuing authority, a draft plan shall be provided prior to the Notice to Proceed. Construction may not commence until the traffic control plan has received the approval of the issuing authority and the Department. Such plans may be revised as necessary with Department concurrence.
- (7) The construction of the access and its appurtenances as required by the terms and conditions of the permit shall be completed at the expense of the permittee except as provided in subsection 2.14. All materials used in the construction of the access within the highway right-of-way or on permanent easements, become public property. Any materials removed from the highway right-of-way will be disposed of only as directed by the Department. All fencing, guard rail, traffic control devices and other equipment and materials removed in the course of access construction shall be given to the Department unless otherwise instructed by the permit or the Department inspector.
- (8) All construction drawings shall be completed to the detail necessary to ensure that the construction of the access will be in compliance with the permit terms and conditions, including materials specifications.
- (9) A Notice to Proceed shall be considered expired if the permit has expired. The Notice to Proceed may have a specific expiration date noted if it is necessary to condition the notice with a specific expiration date.

2.5 Access Construction

- (1) The permittee shall notify the individual or the office specified on the permit or Notice to Proceed at least two working days prior to any construction within state highway right-of-way. Construction of the access shall not proceed until both the access permit and the Notice to Proceed are issued. The access shall be completed in an expeditious and safe manner and shall be finished within 45 days from initiation of construction within the highway right-of-way. A construction time extension not to exceed 30 working days may be requested from the individual or office specified on the permit.
- (2) The Department or issuing authority may restrict work on or immediately adjacent to the highway, control lane closure periods and require pre-approval of all aspects of construction phasing, where access construction will affect traffic operation, roadway capacity and safety. Every effort shall be made to minimize the closure periods of any travel lanes. Work in the right-of-way will normally not be allowed on holidays, at night, during peak traffic hours, and during adverse weather conditions. The issuing authority may establish a fee schedule to charge an hourly and or daily fees for the closure of any travel lanes necessary for the construction of a private access (see subsection 2.11(2)).
- (3) The issuing authority and the Department may inspect the access during construction and upon completion of the access to ensure that all terms and conditions of the permit are met. Inspectors are authorized to enforce the conditions of the permit during construction and to halt any activities within state right-of-way that do not comply with the provisions of the permit, that conflict with concurrent highway construction or maintenance work, that endanger highway property, natural or cultural resources protected by law, or the health and safety of workers or the public.
- (4) The permittee should arrange for access construction to be done by qualified contractors. Work shall be accomplished under Department or local authority inspection and shall meet all Department specifications.
- (5) The Department or issuing authority at its discretion, may complete the installation of permanent traffic control devices. The permittee shall pay for direct costs and labor provided by the Department for the installation and relocation of all traffic control devices within public right-of-way directly related to the use or construction of the permitted access. Failure of the permittee to pay within a reasonable period may be considered grounds for permit suspension which may lead to revocation and access removal.
- (6) Prior to using the access, the permittee is required to complete the construction according to the terms and conditions of the permit. Failure by the permittee to abide by all permit terms and conditions shall be sufficient cause for the Department or issuing authority to initiate action to suspend or revoke the permit and close the access. If in the determination of the Department or issuing authority the failure to comply with or complete the construction requirements of the permit create a highway safety hazard, such shall be sufficient cause for the summary suspension of the permit. If the permittee wishes to use the access prior to completion, arrangements must be approved by the issuing authority and Department and included in the permit. The Department or issuing authority may order a halt to any unauthorized use of the access pursuant to statutory and regulatory powers. Reconstruction or improvement of the access may be required when the permittee has failed to meet required specifications of design or materials. If any construction element fails within two years due to improper construction or material specifications, the permittee shall be responsible for all repairs. Failure to make such repairs may result in suspension of the permit and closure of the access.
- (7) The permittee shall provide construction traffic control devices at all times during access construction, in conformance with the M.U.T.C.D. as required by section 42-4-104, C.R.S., as amended.

- (8) A utility permit shall be obtained for any utility work within highway right-of-way. Where necessary to remove, relocate, or repair a traffic control device or public or private utilities for the construction of a permitted access, the relocation, removal or repair shall be accomplished by the permittee without cost to the Department or issuing authority, and at the direction of the Department or utility company. Any damage to the state highway or other public right-of-way beyond that which is allowed in the permit shall be repaired immediately. The permittee is responsible for the repair of any utility damaged in the course of access construction, reconstruction or repair.
- (9) The permittee shall ensure that a copy of the permit is available for review at the construction site at all times. The permit may require the contractor to notify the individual or office specified on the permit at any specified phases in construction to allow the field inspector to inspect various aspects of construction such as concrete forms, subbase, base course compaction, and materials specifications. Minor changes and additions may be ordered by the Department or local authority field inspector to meet unanticipated site conditions. The Department or issuing authority may require the permittee to hire a Colorado registered professional engineer to affirm to the best of the engineer's knowledge and belief that the construction is in substantial compliance with the permit and specifications. The issuing authority and Department may require testing of materials. When so required, test results shall be provided to the Department.

2.6 Changes in Land Use and Access Use

- (1) It is the responsibility of the property owner and permittee to ensure that the use of the access to the property is not in violation of the Code, permit terms and conditions or the Act. The terms and conditions of any permit are binding upon all assigns, successors-in-interest, heirs and occupants. If any significant changes are made or will be made in the use of the property which will affect access operation, traffic volume and or vehicle type, the permittee or property owner shall contact the local issuing authority or the Department to determine if a new access permit and modifications to the access are required.
- (2) The intent of this subsection is to recognize that beneficial modifications to existing developed property are to be encouraged. The redevelopment, reconstruction, remodeling, assemblage, and any other modifications to existing property will allow the property to retain some direct access if direct access currently exists. Where there is a private access to category F-W or E-X, a change in the use of the access requires full conformance with the standards of the category and may require closure of the access to achieve conformance.
- (3) Unless there are identified safety problems, existing legal access to the state highway system shall be allowed to remain or be moved or reconstructed under the terms of an access permit in accordance with subsection 2.6 as long as total daily trips to and from the site are less than 100, or as long as only minor modifications are made to the property or as long as the access does not violate any specific permit terms and conditions. Minor modifications are defined as anything that does not increase the proposed vehicle volume to the site by 20 percent or more. When a field approach is used or will be used in excess of an average of one vehicle per day, such change in use disqualifies the approach as a field approach, and requires conformance with Section Three of the Code. Subsection 2.6 does not apply.
- (4) Modifications to an existing highway access which is either in use or can demonstrate historical use, and does not comply with the provisions of Paragraph 3 above, may be granted according to the following provisions:
 - (a) Upon demonstration by the applicant that the proposed access point(s) will improve the operation or safety of the highway. Consolidation of access points is encouraged and shall be defined as a benefit to the highway for application of this rule. Where there are multiple accesses serving the site, a 50% reduction (rounded up for odd numbers) shall be sufficient.

- (b) If (a) cannot be demonstrated, then the Department may require closure of those accesses to the state highway which are in excess of those allowed for undeveloped properties according to the criteria of the Access Code.
- (c) The applicant may be required to comply with the requirements of the local jurisdiction and the Code, pertaining to public improvements, auxiliary lanes, and other access design criteria to the extent possible in order to maintain safe operations of the roadway system in accordance with the needs of the access category.
- (5) A change in use which results in a change in the type or nature of access operation is presumptively established when, following the change in use, any of the events enumerated occur or reasonably are expected to occur by proper application of the ITE Trip Generation manual or by actual counts and reasonable predictions.
- (6) Vehicular use and operation of local roads where they connect to (access) a state highway is the responsibility of the appropriate local authority. The local authority should maintain such state highway access locations in conformance with the Code to the extent feasible and practicable within statutory and public funding limitations. The local authority may fund any necessary improvements by obtaining contributions from the primary users of the access or as off-site subdivision improvements necessary for the public safety pursuant to sections 30-28-133 and 133.1, C.R.S., and sections 31-23-201 to 227, C.R.S., or other available public funds and local requirements.
- (7) The Department or issuing authority may, when necessary for the improved safety and operation of the roadway, rebuild, modify, remove, or relocate any access, or redesign the highway including any auxiliary lane and allowable turning movement. The permittee and or current property owner will be notified of the change. Changes in roadway median design that may affect turning movements normally will not require a license modification hearing as an access permit confers no private rights to the permittee regarding the control of highway design or traffic operation even when that design affects access turning movements.
- (8) Action pursuant to the Code initiated by the local authority or Department against an existing legal access either to revoke, suspend, limit, reconstruct, relocate or modify the access may be accomplished pursuant to either the Administrative Procedure Act, article 4 of title 24, C.R.S., or the government powers of eminent domain.
- (9) All temporary permits in existence as of the effective date of the Code, shall be considered expired on September 1, 2001 unless a specific expiration date was provided on the permit. All new temporary permits shall expire three years from their date of issue unless a date providing for a shorter duration is specified. When the permittee wishes to reestablish the access, the standard application process shall be followed. Continued use of an access that has an expired permit shall be considered illegal access.

2.7 Maintenance & Permit Transfer

- (1) The permittee, his or her heirs, successors-in-interest, assigns, and occupants of the property serviced by the access shall be responsible for meeting the terms and conditions of the permit, the repair and maintenance of the access beyond the edge of the roadway including any cattle guard and gate, and the removal or clearance of snow or ice upon the access even though deposited on the access in the course of Department snow removal operations. Within unincorporated areas the Department will keep access culverts clean as part of maintenance of the highway drainage system. However, the permittee is responsible for the repair and replacement of any access-related culverts within the right-of-way. Within incorporated areas, drainage responsibilities for municipalities are determined by statute and local ordinance. The Department will maintain the roadway including auxiliary lanes and shoulders, except in those cases where the access installation has failed due to improper access construction and/or failure

to follow permit requirements and specifications in which case the permittee shall be responsible for such repair. Any significant repairs such as culvert replacement, resurfacing, or changes in design or specifications, requires authorization from the Department.

2.8 Access Violations

- (1) The Department or issuing authority may install barriers across, or remove, any access which is determined by the Department to be illegal. Any access that provides direct access to a state highway which is constructed and or established without a current and legal access permit after August 30, 1981 shall be considered illegal. Any person who drives a vehicle onto or from any state highway except at permitted access locations commits a traffic infraction pursuant to section 42-4-1010, C.R.S., as amended.
- (2) When an access is constructed or used in violation of the Code, section 43-2-147(5)(c), C.R.S., of the Act applies. The Department or issuing authority may summarily suspend an access permit and immediately order closure of the access when its continued use presents an immediate threat to public health, welfare or safety. Summary suspension shall comply with article 4 of title 24, C.R.S.
- (3) When closure of the access would constitute an undue hardship on access users other than the permittee and assigns and the Department or issuing authority has been unsuccessful in obtaining compliance with the permit by the permittee, and a safety hazard exists with the continued use of the access, the Department or issuing authority may complete the necessary modifications with public funds. The permittee shall reimburse any such public expenditure. The Department or issuing authority shall require reimbursement of these public funds by the permittee, his agents, heirs, successors-in-interests and assigns. Failure of the permittee to reimburse public funds in a reasonable period may result in suspension of the permit or permit revocation and or a lein may be filed.

2.9 Appeals

- (1) Should the permittee or applicant object to the denial of a permit application by the Department or object to any of the terms or conditions of a permit placed there by the Department, the applicant and permittee (appellant) have a right to appeal the decision to the Commission. To appeal a decision, submit a request for administrative hearing to the Transportation Commission of Colorado within 60 days of transmittal of notice of denial or transmittal of the permit for signature. Submit the request to the Transportation Commission of Colorado, 4201 East Arkansas Avenue, Denver, Colorado 80222-3400. The request shall include reasons for the appeal and may include changes, revisions, or conditions that would be acceptable to the permittee or applicant.
- (2) Any appeal by the applicant or permittee of action by a local issuing authority shall be filed with the local authority and be consistent with the appeal procedures of the local authority.
- (3) In submitting the request for administrative hearing, the appellant has the option of including within the appeal a request for a review by the Department's internal administrative review committee pursuant to subsection 2.10. When such committee review is requested, processing of the appeal for formal administrative hearing, 2.9(5) and (6), shall be suspended until the appellant notifies the Commission to proceed with the administrative hearing, or the appellant submits a request to the Commission or the administrative law judge to withdraw the appeal. The two administrative processes, the internal administrative review committee, and the administrative hearing, may not run concurrently.
- (4) Upon receiving a copy of the appeal, the Department may consider any objections and requested revisions at the request of the applicant or permittee and discuss the issues with the appellant. If agreement is reached, the Department, with the approval of the issuing authority (if applicable), may revise the permit accordingly, or issue a new permit, or require the applicant to submit a new

application for the Department's reconsideration. Changes in the original application, proposed design or access use will normally require submittal of a new application. If the appeal includes a request for review by the internal administrative review Committee, the Secretary of the Committee shall be provided a copy of the appeal.

- (5) Regardless of any communications, meetings, administrative reviews or negotiations with the Department or the internal administrative review Committee regarding revisions or objections to the permit or a denial, if the permittee or applicant wishes to appeal the Department's decision to the Commission for a hearing, the appeal must be brought to the Commission within 60 days of transmittal of notice of denial or transmittal of the permit.
- (6) The hearing will be held in accordance with article 4 of title 24, C.R.S. and also in accordance with the Rules of Procedure, Department of Administration, Division of Administrative Appeals, 1-CCR-104-1, and section 24-4-105, C.R.S., if the hearing is delegated to an Administrative Law Judge.
- (7) The decision by the Commission or by an administrative law judge to whom the appeal is delegated, shall be considered final agency action. The standard of review by the Commission or by the administrative law judge is set forth in section 24-4-106, C.R.S. as amended.
- (8) The Department or local authority may record any application or permit decision and related documents with the County Clerk and Recorder.

2.10 Internal Administrative Review Committee

- (1) The Executive Director of the Department shall establish an Access Code Administrative Review Committee ("Committee") in the Office of the Chief Engineer, and appoint three members, for the review of Department access decisions and administration. The purpose of the Committee is to help ensure the uniform administration of the Code and to seek resolution of disagreements as an optional alternative to conducting a formal administrative hearing pursuant to subsection 2.9. No more than two of the three members shall be employed by the Department. Two additional persons shall be appointed as alternates to serve in the absence of a member, or when, in the opinion of the chairperson, a member may be faced with a conflict of interest. The Committee shall select a chairperson. A member may choose to recuse himself/herself from any case review without providing justification. One alternate shall be a Department employee. The Chief Engineer shall assign a Department employee as the non-voting Committee secretary, who will accomplish the Committee's administrative duties including letters, scheduling, preparation of written materials, distribution, record keeping and related duties, and prepare any materials requested by the Chief Engineer.
- (2) A request for Committee review must be submitted in writing as a part of the appeal process pursuant to section 2.9. The request must be received by the Transportation Commission of Colorado within 60 days of transmittal of notice of denial or transmittal of the permit for signature. The request to the Committee is optional. A permittee or applicant may elect to bypass the review process described in this subsection and proceed to an administrative hearing. A request for Committee review may not be submitted until the Region has concluded its access permit review process and made a decision. The applicant should provide complete written information supporting their request for Committee review. The applicant may make a personal appearance before the Committee or chose not to appear and rely on the Committee to read and discuss any submitted materials.
- (3) Upon receipt of a request for review, the Committee secretary shall promptly notify the local jurisdiction and appropriate Region. The Secretary will schedule the review meeting based upon the meeting dates selected by the Committee, the convenience of the applicant, and the availability of the Department representatives. The Secretary shall provide notice of the meeting to all parties. The secretary will notify the appellant and the Region at least 10 working days in advance of the Committee meeting unless waived by both parties. The Committee has no

authority over local issuing authorities. The Secretary shall direct all review requests regarding local issuing authority decisions to the appropriate local authority.

- (4) The Committee shall meet regularly, as the Committee deems necessary, to provide a timely response to review requests. The Committee will normally consider each request within 30 calendar days of receipt.
- (5) The appellant shall present their issues first at the Committee meeting. The presenters for the appellant shall have authority to represent the appellant. They have no more than 30 minutes to present. The Department representative will follow, not to exceed 30 minutes to present. The proponent may have a five minute response to the Department presentation. If requested, the Committee chair may extend the allotted times. Following the presentations the Committee may ask questions of any party.
- (6) Following the presentations and questions if any, the Committee, in reaching their recommendation, shall consider all information received, the requirements of the Code, the Statement of Purpose and Intent contained in the Code, and any relevant Department policies and engineering practices. If the Committee finds there is insufficient information, the Committee may call a continuance to a later date and postpone its recommendation to the Chief Engineer. The Committee shall make an initial recommendation which will include the Committee's opinion regarding the facts, and findings. The Committee shall arrive at an initial recommendation prior to beginning a hearing on a new case. Within 10 days, the Committee secretary shall prepare the recommendation in writing, obtain the concurrence of the Committee, and forward the written recommendation to the Chief Engineer.
- (7) Following receipt of the Committee recommendations, the Chief Engineer shall take the Committee's recommendations under advisement. The Chief Engineer has 10 days to review the Committee's recommendation and make a final decision. The Chief Engineer, based on his/her judgement, the Code and the recommendation of the Committee, shall direct Department staff to take appropriate action to either modify the permit, let the permit stand as offered originally, or uphold the Region determination. The Chief Engineer's decision shall be in writing. It shall include a listing of the facts, findings, applicable provisions of law and a decision. All parties to the review will be sent a copy of the decision. This will be considered the Department's final internal decision regarding the access application. The Secretary shall keep a separate record of all recommendations and decisions. Failure of the Chief Engineer to comply with the time frame set forth herein cannot be used as a basis for an argument that any certain decision has been made on an appeal.
- (8) In conjunction with the Department staff, interested local governments, and private sector persons, the Committee may conduct quality assurance reviews of the access Code process, services and resources, as the Committee may deem appropriate or as requested by the Executive Director or Chief Engineer.

2.11 Permit Fees, Forms and Records

- (1) The issuing authority shall establish and collect a reasonable schedule of fees for access permits issued pursuant to the Code. Permit fees shall not exceed the costs of the administration of access permits. Local governments which are issuing authorities shall inform the Department of their fee schedules if any.
- (2) The issuing authority may establish a fee schedule to charge an hourly and or daily fees for the closure of any travel lanes necessary for the construction of a private access. The fees will be estimated on the delay and interference caused by the closure on the general public. Such fees are applicable if for any part of any hour travel lane closure will result in a lower level of service and in a level of service lower than "D". The lane closure fee shall be no less than \$200 per hour per day or \$600 per day whichever is less. The purpose of the fee is to encourage the quick

completion of all work that reduces highway capacity and safety or interferes with the through movement of traffic.

- (3) Each issuing authority shall make applications forms and related materials available to the public. The Department shall provide to the issuing authority all official Department forms necessary for processing access applications, including the permit form and any other official access permit program forms used, to ensure consistent record keeping and legal and administrative action on the part of all those charged, in whole or in part, with the administration of the Code.
- (4) A copy of the permit issued shall be maintained by the Department and the local issuing authority for as long as the permitted access is in existence pursuant to the permit. The Department shall be provided access to the access permit records of any local issuing authority for the purposes of auditing to verify that all access applications and permits have been properly processed and approved.

2.12 Access Control Plans

- (1) Either the Department or the appropriate local authority may, at its discretion, develop an access control plan for a designated portion of state highway. An access control plan provides the appropriate local authority and the Department with a comprehensive roadway access design plan for a designated portion of state highway for the purpose of bringing that portion of highway into conformance with its access category and its functional needs to the extent feasible given existing conditions. The plan should achieve the optimum balance between state and local transportation planning objectives, and preserve and support the current and future functional integrity of the highway.
- (2) The access control plan shall indicate existing and future access locations and all access related roadway access design elements, including traffic signals, that are to be modified and reconstructed, relocated, removed, added, or remain. The plan shall not preclude the current or future accommodation of other transportation modes of bicycles, pedestrian and transit. All traffic control devices or modifications shall meet the requirements of the M.U.T.C.D. as required by state and federal statutes. To the extent practical the plan shall meet the functional characteristics and design standards of the assigned category and conform to all standards and specifications in the Code. To determine the sufficiency and ensure that the plan will be successful, a study will be completed incorporating the appropriate elements of Code section 2.3 and included as supporting information for Department review. At least one advertized public meeting shall be held during the development phase of the plan. All property owners of record abutting the state highway within the plan limits shall be notified by the Department or the appropriate local authority of the proposed plan and afforded the opportunity to submit any information, data and agreements regarding the proposed plan.
- (3) The plan must receive the approval of both the Department and the appropriate local authority to become effective. This approval shall be in the form of a formal written agreement signed by the local authority and the Chief Engineer of the Department. After an access control plan is in effect, modifications to the plan must receive the approval of the local authority and the Department. Where an access control plan is in effect, all action taken in regard to access shall be in conformance with the plan and current Code design standards unless both the Department and the local authority approve a geometric design waiver under the waiver subsection of the Code.

2.13 Interchange Management Plans

- (1) An interchange management plan is required for any new interchange or significant modification to an existing interchange. The interchange and the management plan must receive the approval of the Chief Engineer.

- (2) An interchange management plan is a simplified roadway, right-of-way and access control concept plan for the intersection of roadways where an interchange structure exists or is to be built or modified. Such plan shall include schematics for the location of all future and current access locations, public and private; anticipated traffic patterns, traffic signal locations, signing and striping; the acquisition of access rights where necessary; and any other controls that will ensure the continued protection of the functional integrity of the interchange including those roads entering the interchange area providing access to the freeway.
- (3) Plan development procedures may follow the requirements of subsection 2.12, Access Control Plans, where they apply. The design of the plan should be developed using desirable level standards of traffic operation planning and roadway design standards where feasible. Access rights should be obtained for a distance of 550 feet along the lesser street or cross road measured from the radius point of any ramp touch down curve. Frontage roads and other accesses which are closer to ramp termini than the spacing standards recommend, should be either relocated, closed, or turning movements restricted as soon as conditions allow.

2.14 Department And Local Government Highway Construction Projects

- (1) When in the course of highway improvement it is necessary to reconstruct, improve, relocate, close or bring into conformance with the Code an existing access or accesses, the Department or issuing authority will initiate the appropriate procedures, permits and agreements. Written concurrence by the appropriate local authority in the design plans illustrating access changes or by correspondence will constitute concurrence pursuant to section 43-2-147(6)(b), C.R.S. of the Act.
- (2) Where the local authority retains issuing authority, the Department may request temporary administrative authority to issue access permits for any access within a designated highway project segment, or the issuing authority may be requested to concur in each access permit prior to permit approval by the Department. Access permits issued within the project limits should be constructed within two years from the date of issue. Extensions may be approved. Construction procedures and timing may be consistent with any project contract requirements.
- (3) An access may not be upgraded to serve a greater purpose unless such improvement is allowed by an appropriate permit. The cost of any upgrade shall be at the expense of the property owner if necessitated by changes or anticipated changes in the use of the property.
- (4) A public highway reconstruction project is not required to bring legal access into full compliance with current Code standards, but only to the extent reasonable within the limitations and scope of project consistent design parameters and available public funds.
- (5) Where there are multiple accesses to the same ownership, public highway reconstruction may result in the combining and reduction of the number of driveways or modification of driveway size and design in order to meet necessary design and safety standards. The appropriate local authority may exercise its own legal authorities, resolutions and ordinances, to reduce the number of driveways to an ownership. Such local authority does not extend to the opening of new access to state highways except as allowed by state law.
- (6) Temporary access within a highway project construction zone for highway construction activity is permissible. A permit is required for any new access location that provides access to the traveled portion of the roadway. The design, use and traffic controls of the access shall be detailed in the permit and on the project's traffic control plan. Where there is no project traffic control plan, flaggers shall be provided or the permit shall meet the standard design requirements of the Code.
- (7) Under no circumstances shall the construction or reconstruction of a private driveway by a private interest interfere with the completion of a public highway construction project. The private interest shall coordinate work with Department project engineer.

Section Three Access Category Standards

3.1 Purpose and Use

- (1) This section provides a system of eight highway categories for access control purposes. The number, spacing, type, and location of access and traffic signals have a direct and often significant effect on the capacity, speed, and safety of the highway and are limited in a hierarchical method by this category system. The location, operation and design standards within each category are necessary to ensure that the highway will continue to function at the level (category) assigned. Each state highway segment is assigned a category as provided in subsection 2.2 of the Code. These assignments are listed in the State Highway Access Category Assignment Schedule, 2 CCR 601-1A, which can be obtained from the issuing authority.
- (2) The standards in this section have been written so that the safety and operations of the complete general street system will be considered, when determining access to the state highway.
- (3) The “*Functional Characteristics and Category Assignment Criteria*”, subsection of each category is intended to describe the existing or future function of roadways for which that category is most appropriate. The existing design of the highway is not required to meet the design standards of the assigned category at the time it is assigned. All new access permitting and other access design decisions shall meet the design standards in this section for the assigned category for the highway or segment of highway. A proposed access that may be allowed under Code Section Three criteria, but fails to meet the design or safety criteria of Code Section Four, should be denied unless a design waiver can be approved.
- (4) Traffic signals and their installation are also regulated by the Federal *Manual on Uniform Traffic Control Devices*, (M.U.T.C.D.) and the Colorado Supplement under section 42-4-104, C.R.S., as amended. Nothing in the Code is intended or shall be interpreted as requiring the Department to authorize a traffic signal or left turn movement at any location. No traffic signal shall be authorized without the completion of an analysis of traffic signal system operation, construction feasibility, and safety as well as meeting M.U.T.C.D. signal warrants. When a traffic signal or operations study is required, the study shall include the information, data and analysis requirements of section 2.3(5) to the extent requested by the Department and issuing authority and be sealed by a Colorado registered professional engineer. The Department may at its discretion in consideration of granting an access permit, require design and operational modifications as it considers necessary, restrict one or more turning movements, or deny the access so long as such discretion does not violate law.

Table 3.1: Overview of the Access Category Classification Hierarchy

Table of access categories, with approximate descriptions	
F-W Interstate System, Freeway Facilities	
E-X Expressway, Major Bypass	
Rural	Non-Rural
R-A Regional Highway	NR-A Regional Highway
R-B Rural Highway	NR-B Arterial
	NR-C Arterial
F-R Frontage Roads (both urban and rural)	

3.2 Access to Designated Freeways

- (1) The freeway statute, section 43-3-101 et seq., C.R.S., first adopted in 1941, controls public way access to state highways that are designated freeways by the Commission. Access permits for public way access to these highways shall not be issued unless prior authorization is obtained pursuant to section 43-3-104, C.R.S. This also applies to any private access that is proposed to

become a dedicated public way in the future. Any restrictions placed on such approvals may be reflected in the access permit.

3.3 Emergency Access

- (1) Emergency access may be permitted on categories R-A, R-B, NR-A, NR-B, NR-C and F-R where required by local safety regulations. Such direct emergency access may be permitted only if it is not feasible to provide the emergency access to a secondary roadway. A written explanation with references to local standards from an appropriate government safety official shall be included with the application.

3.4 Field Approaches

- (1) Field approaches may be granted to categories R-A, R-B, NR-A, NR-B, NR-C, and F-R where in the determination of the issuing authority and the Department, the field has no other sensible access. Additional field approaches to property under the same ownership or controlling interest may be granted if the necessity for such additional access due to topography or ongoing agricultural activities is demonstrated. Field approaches shall be kept to the minimum necessary to provide access service. Field approaches should meet minimum access design and safety standards of the Code. A change in use of the parcel of land serviced by the field approach may require that the field approach be closed. The spacing criteria between accesses contained in the Code may be waived for field approaches. All such field accesses shall meet the sight distance criteria of the Code.

3.5 Auxiliary Turn Lanes

- (1) Auxiliary lanes are required as described within each category in Section Three. In addition, auxiliary lanes may also be required where any of the following subsections require.
- (2) If necessary, for specifically identified and documented safety and operation reasons, a right turn acceleration lane may be required when, a) for any access where a high traffic volume on the highway or using the access and the lack of acceptable gaps in traffic make use of an acceleration lane necessary for vehicles to safely and efficiently enter the highway traffic flow through the use of available short gaps in traffic, or b) where necessary for public safety and traffic operations based upon site and roadway specific conditions such as horizontal and vertical curves, or c) the posted speed is greater than 40 MPH.
- (3) If necessary, for specifically identified and documented safety and operation reasons, a left turn acceleration lane may be required when unique location factors such as; highway speed and traffic density, access volume, the volume of commercial trucks, the influence of nearby access, existing highway auxiliary lanes close to the access, nearby traffic control devices, available stopping sight distance, and where other topographic and highway design factors exist that determine the need.
- (4) For those access locations that have a high percentage of trucks using the access, it may be required that each auxiliary lane be built to full length and width according to table 4-6 and the transition taper length shall extend beyond the full length.
- (5) The auxiliary lanes required in the category design standards may be waived when the 20th year predicted roadway volumes conflicting with the turning vehicle are below the following minimum volume thresholds. The right turn deceleration lane may be dropped if the volume in the travel lane is predicted to be below 150 DHV. The left turn deceleration lane may be dropped if the opposing traffic is predicted to be below 100 DHV. The right turn acceleration lane may be dropped if the adjacent traveled lane is predicted to be below 120 DHV. The left turn acceleration

lane may be dropped if the volume in the inside lane in the direction of travel is predicted to be below 120 DHV.

3.6 Category F-W - Interstate System, Freeway Facilities

Functional Characteristics and Category Assignment Criteria

- (1) This category is appropriate for use on highways that have the capacity for high speed and relatively high traffic volumes over medium and long distances in an efficient and safe manner. They provide for interstate, interregional, intra-regional, intercity and, in larger urban areas, intracity travel. Interstate freeways are typical of this category.

Access Granting Criteria Including Category Related Access Location, Operation and Design Standards

- (2) All opposing traffic movements shall be separated by physical constraints such as grade separations and non-traversable median separators. Access to the roadway, when allowed, shall consist of directional ramps, shall be suitably spaced and designed to provide the minimum differential between the speed of the through traffic stream and the speed of the merging or diverging vehicles. Location and design of access shall be determined on an individual basis by the Department in accordance with its authority under section 43-3-101 et seq., C.R.S., as amended, this Code, and the federal regulations governing federal-aid highway design and construction. Private direct access to the F-W roadway is prohibited without exception. Except for temporary emergency and project construction access, each access allowed to a category F-W highway must receive the specific approval of the Chief Engineer and the Commission. Access to category F-W highways must comply with federal regulations and may require Federal Highway Administration "FHWA", approvals.
- (3) Auxiliary lane design and lengths shall meet federal Interstate design practices and be approved by the Department. The lengths shall be no less than that required by category E-X.
- (4) Temporary access may be allowed for official emergencies. Temporary access may be allowed by a Department Region Transportation Director with FHWA concurrence where directly related to an access category F-W highway construction project. Temporary construction related access outside the construction zone may be allowed only if no reasonable alternative exists and the access meets Code Section Four standards. Such access may also require FHWA approval. Temporary access within a construction zone shall be incorporated into the approved traffic control plans.
- (5) Access onto category F-W highway right-of-way but not to the roadway may be permitted by special Department license or agreement if approved by the FHWA and the Chief Engineer, where such access will not connect to the main roadway, and may be for such purposes as bike and pedestrian paths, drainage, underpasses, overpasses, utilities and related public necessities which will not connect to or interfere with the main roadway, ramps, or cause any type of highway safety, operational, or design deficiencies.
- (6) All private direct access to category F-W main roadways, access ramps, and structures is strictly prohibited unless specifically authorized for official temporary highway construction purposes under Department contract. Access to a frontage road built in association with a category F-W roadway, may be permitted in accordance with the assigned access category of the frontage road.
- (7) A new interchange or a significant modification to an interchange on a F-W category highway, requires an interchange management plan. See subsection 2.13.

3.7 Category E-X - Expressway, Major Bypass

Functional Characteristics and Category Assignment Criteria

- (1) This category is appropriate for use on highways that have the capacity for high speed and relatively high traffic volumes in an efficient and safe manner. They provide for interstate, interregional, intra-regional, and intercity travel needs and to a lesser degree, some intracity travel needs. Direct access service to abutting land is subordinate to providing service to through traffic movements.

Access Granting Criteria Including Category Related Access Location, Operation and Design Standards

- (2) Typical spacing of intersecting streets, roads and highways shall be planned on intervals of one mile and normally based upon section lines where appropriate. One-half mile spacing of public ways may be permitted to the highway only when no reasonable alternative access to the general street system exists.
- (3) No access to private property may be permitted unless reasonable access cannot be obtained from the general street system. When private access is permitted, left turns may be allowed if in the opinion of the department such left turns can be reasonably accomplished and it is not a divided highway. When direct private access is permitted, appropriate terms and conditions shall be included in the permit to achieve the following criteria; a) the access should be closed when other reasonable access to a lower functional street, road or highway is reasonably available, b) the access permit should specify under what circumstances the closure may be required, and c) if known, the future access location and the date the closure may occur.
- (4) When allowed, auxiliary turn lanes shall be installed according to the criteria below.
 - (a) A left turn deceleration lane is required for any access with a projected average daily left turn ingress volume greater than 10. The transition taper length will be included within the required deceleration length. If the projected peak hour left ingress turning volume is greater than 10 vph, a left turn lane with deceleration, storage, and transition taper lengths is required for any access.
 - (b) A right turn lane with deceleration and taper lengths is required for any access with a projected peak hour right turn ingress turning volume greater than 10 vph.
 - (c) A right turn lane with acceleration and taper lengths is required for any access with a projected peak hour right turning volume greater than 10 vph.
 - (d) A left turn acceleration lane may be required if such a design would be a benefit to the safety and operation of the roadway or as determined by subsection 3.5. Left turn acceleration lanes are generally not required where; the posted speed is less than 45 mph, or the intersection is signalized, or the acceleration lane would interfere with the left turn ingress movements to any other access.
 - (e) If left turns are allowed and no left turn lane is required, then a minimum of a 10 foot outside shoulder in the direction of the left turning vehicle may be required.
- (5) Unless otherwise specifically categorized and individually referenced by the State Highway Access Category Assignment Schedule, or noted in category F-W, private direct access should be prohibited from all vehicular overpasses, underpasses, bridges, structures, and ramps, on or connected to any state highway.

- (6) No additional access rights shall accrue and no additional access shall be provided upon the splitting or dividing of existing parcels of land or contiguous parcels under the same ownership or controlling interest. All access to the newly created properties shall be provided internally from the existing access or a new access determined by the permit application or subdivision procedures.
- (7) All access provided to a category E-X highway shall be done so with the understanding that if the highway is reconstructed, the direct access location may be closed and alternative access may be required to a frontage road or by other available means.
- (8) Signals at intersections with major cross streets or roads of equal importance may be programmed to optimize traffic on both streets equally. Cross-streets of lesser importance need not be optimized equally. Traffic signals on the highway should be programmed to allow a desirable highway bandwidth of at least 40 percent. The efficiency of the signal system should be analyzed utilizing traffic volume, capacity, and level of service calculations. A study including all the relevant information listed in subsection 2.3(5) shall be completed. The analysis shall determine the optimum progression speed under both existing and proposed conditions.

3.8 Category R-A - Regional Highway

Functional Characteristics and Category Assignment Criteria

- (1) This category is appropriate for use on highways that have the capacity for medium to high speeds and relatively medium to high traffic volumes over medium and long distances in an efficient and safe manner. They provide for interregional, intra-regional, and intercity travel needs. Direct access service to abutting land is subordinate to providing service to through traffic movements. This category is normally assigned to National Highway System routes, significant regional routes in rural areas, and other routes of regional or state significance.

Access Granting Criteria Including Category Related Access Location, Operation and Design Criteria

- (2) When application is made, one access shall be granted per parcel of land if reasonable access cannot be obtained from the local street or road system. Reasonable local access will be determined in consultation with the appropriate local authority. A determination of reasonable access from a local street or road should include consideration of the local street or road function, purpose, capacity, operational and safety conditions and opportunities to improve the local street or road. Direct access to the highway should not be denied if the alternative local access would create a significant operational or safety problem at the alternative location and the direct access to the state highway would not be a significant problem to the highway.
- (3) (a) The standard for the spacing of all intersecting public ways and other accesses that will be full movement, or are or may become signalized, is one-half mile intervals, and based upon section lines where feasible. Exceptions to this one-half mile standard shall not be permitted unless the proposal documents that there are no other reasonable alternatives to achieve a one-half mile interval, there is a documented necessity for the intersection at the proposed location, and a signal study acceptable to the Department is completed in accordance with section 2.3(5).
- (b) Where it is not feasible to meet one-half mile spacing and where signal progression analysis indicates good progression (35 percent efficiency or better), or does not degrade the existing signal progression, a full movement may be allowed. Spacing to nearby intersections shall be sufficient to accommodate the 20th year left turn vehicle storage queue for both turning movements. The access location must also meet other Code access spacing, design and need requirements. If 20th year projections for the access indicate that the access volumes would be less than 75 percent of those required for M.U.T.C.D. traffic signal volume warrants, or if there are less than two nearby (within one

mile either direction) accesses that are or could be signalized, the intersection location does not need to be on one-half mile spacing, nor does it need to meet progression analysis criteria.

(c) Where topography or other existing conditions make one-half mile intervals inappropriate or not feasible, location of the access shall be determined with consideration given to topography, established property ownerships, unique physical limitations and or unavoidable or pre-existing historical land use patterns and physical design constraints with every attempt to achieve a spacing of one-half mile. The final location should serve as many properties and interests as possible to reduce the need for additional direct access to the state highway. In selecting locations for full movement intersections, preference shall be given to public ways that meet or may be reasonably expected to meet signal warrants in the foreseeable future.

(4) If a restrictive median exists, left turns at unsignalized intersections should be restricted, unless the restriction of these movements would cause a safety or operations problem, or cause an out-of-direction movement of greater than one mile. If a traversable median exists, left turns will be permitted unless an operational or safety problem is identified.

Auxiliary Lane Requirements

(5) Auxiliary turn lanes shall be installed according to the criteria below.

(a) A left turn deceleration lane with taper and storage length is required for any access with a projected peak hour left ingress turning volume greater than 10 vph. The taper length will be included within the required deceleration length.

(b) A right turn deceleration lane and taper length is required for any access with a projected peak hour right ingress turning volume greater than 25 vph. The taper length will be included within the required deceleration length.

(c) A right turn acceleration lane and taper length is required for any access with a projected peak hour right turning volume greater than 50 vph when the posted speed on the highway is greater than 40 mph. The taper length will be included within the required acceleration length. A right turn acceleration lane may also be required at a signalized intersection if a free-right turn is needed to maintain an appropriate level of service in the intersection.

(d) Right turn deceleration and acceleration lanes are generally not required on roadways with three or more travel lanes in the direction of the right turn except as provided in subsection 3.5.

(e) A left turn acceleration lane may be required if it would be a benefit to the safety and operation of the roadway or as determined by subsection 3.5. A left turn acceleration lane is generally not required where; the posted speed is less than 45 mph, or the intersection is signalized, or the acceleration lane would interfere with the left turn ingress movements to any other access.

(6) No additional access rights shall accrue upon the splitting or dividing of existing parcels of land or contiguous parcels under or previously under the same ownership or controlling interest. All access to newly created properties shall be provided internally from any existing access or a new access determined by Code design standards or by permit application and consistent with this subsection.

(7) When an existing access meets the warrants for a traffic signal as defined in the M.U.T.C.D., and the location does not meet the requirements of subsection 3.8(3), the access shall be reconstructed

to eliminate or reduce the traffic movements that cause the traffic signal warrant to be met, and the access brought into conformance with appropriate design criteria. A raised median may be required. Closure may be required if alternative reasonable access is available.

- (8) With the exception of frontage roads, any new rural highway location or newly designated state highway shall be considered no less than an access category R-A highway until the Commission has specifically assigned an access category.
- (9) Where frontage and service roads are present, unless otherwise specifically categorized, a category R-A shall be assumed for all at-grade rural roadway sections within Department right-of-way between frontage and service roads and the main roadway.

3.9 Category R-B - Rural Highway

Functional Characteristics and Category Assignment Criteria

- (1) This category is appropriate for use on highways that have the capacity for moderate to high travel speeds and low traffic volumes providing for local rural travel needs. Speed limits vary based on roadway design, location, and travel speeds. There is a reasonable balance between safety, direct access and mobility needs within this category. This category may be assigned to low volume minor arterials, secondary collectors and local highway sections that do not normally provide for significant regional, state or interstate travel demands. These highways typically provide for rural transportation needs including, farm to market, farm to farm, and may include high speed rural frontage roads.

Access Granting Criteria including Category Related Access Location, Operation and Design Standards

- (2) When application is made, one access shall be granted to each parcel, unless the Department or Issuing authority establishes that the access would create a significant safety or operational problem on the highway, or the access does not meet acceptable design standards.
- (3) Turning movements shall not be restricted if the access meets sight distance requirements, and auxiliary lane design requirements are met, no restrictive median is present, and if 20-year projections indicate that the intersection volumes would be less than 75 percent of those required for M.U.T.C.D. traffic signal volume warrants. Left or right turn movements may be restricted only if, in the determination of the Department or the issuing authority, one or both movements create significant roadway congestion or safety problems or hazards or a restrictive median is already in place.
- (4) Left turns shall be prohibited if a non-traversable median is already established and the proposed opening in the median does not provide the general public any significant benefits to highway traffic operations and safety or would be counter to the purpose of the median.
- (5) Additional access may be granted if the size or trip generation potential of the parcel requires additional access to maintain good roadway traffic operations and land use design, unless the Department or Issuing authority establishes that the access would create a significant safety or operational problem, or the access does not meet acceptable design standards including spacing. Any additional access must not interfere with the location, planning, and operation of the general street system and access to nearby properties. Where the property abuts or has primary access to a lesser function road or an internal street system or by way of dedicated rights-of-way or easements, any access to the state highway shall be considered as an additional access.
- (6) The recommended spacing of all intersecting public ways and other significant accesses that will be full movement is one-half mile intervals, and based upon section lines where feasible. Where topography or other existing conditions make one-half mile intervals inappropriate or not feasible,

location of the access shall be determined with consideration given to topography, established property ownerships, unique physical limitations and or unavoidable or pre-existing historical land use patterns and physical design constraints with a reasonable attempt to achieve a spacing of one-half mile. The final location should serve as many properties and interests as possible to reduce the need for additional direct access to the state highway. In selecting locations for full movement intersections, preference shall be given to public ways that meet or may be reasonably expected to meet signal warrants in the foreseeable future.

- (7) If the access has the potential to meet the M.U.T.C.D. warrants for signalization, the access location should meet signal spacing and location requirements. Where 20-year traffic projections exceed 75 percent of those required for M.U.T.C.D. Traffic Signal Volume Warrants, a traffic signal progression analysis shall be done. Where signal progression analysis indicates good progression (25 percent efficiency or better), or does not degrade the existing signal progression, a full movement may be allowed. In selecting access locations that may become signalized, preference shall be given to public ways that meet the one-half mile standard. No traffic signal shall be authorized without the completion of an analysis of traffic signal system operation, design and safety as well as meeting M.U.T.C.D. signal warrants.

Auxiliary Lane Requirements

- (8) Auxiliary turn lanes shall be installed according to the criteria below.

- (a) A left turn deceleration lane with taper and additional storage length is required for any access with a projected peak hour left ingress turning volume greater than 10 vph. The taper length shall be included within the required deceleration length.
- (b) A right turn deceleration lane with taper is required for any access with a projected peak hour right ingress turning volume greater than 25 vph. The taper length shall be included within the required deceleration length.
- (c) A right turn acceleration lane with taper is required for any access with a projected peak hour right turning volume greater than 50 vph when the posted speed on the highway is 45 mph or greater and the highway has only one lane for through traffic in the direction of the right turn. A right turn acceleration lane is not required on multi-lane highways of this category. The taper length will be included within the required acceleration length.
- (d) A left turn acceleration lane with taper may be required if it would be a benefit to the safety and operation of the roadway or as determined by subsection 3.5. A left turn acceleration lane is generally not required where: the posted speed is less than 45 mph, or the intersection is signalized, or the acceleration lane would interfere with the left turn ingress movements to any other access.

- (9) If the proposed access will not meet Section Four design and spacing standards, the access may be denied if absent the proposed access the property has reasonable alternate access available to the general street system.

3.10 Category NR-A - Non-Rural Principal Highway

Functional Characteristics and Assignment Criteria

- (1) This category is appropriate for use on non-rural highways that have the capacity for medium to high speeds and provide for medium to high traffic volumes over medium and long distances in an efficient and safe manner. They provide for interregional, intra-regional, intercity, and intracity travel needs in suburban and urban areas as well as serving as important major arterials in smaller cities and towns. Direct access service to abutting land is subordinate to providing service

to through traffic movements. This category is normally assigned to National Highway System routes, and other routes of regional or state significance.

Access Granting Criteria including Category Related Access Location, Operation and Design Standards

- (2) When application is made, one access shall be granted per parcel if reasonable access cannot be obtained from the local street or road system. Reasonable local access will be determined in consultation with the appropriate local authority. A determination of reasonable access from a local street or road should include consideration of the local street or road function, purpose, capacity, operational and safety conditions and opportunities to improve the local street or road. Access to the highway should not be denied if the access will not create a safety or operational problem to the highway but would create safety or operational problems on the local street or road or cause the local street or road to be used in a manner which it was not intended.
- (3) The desirable standard for the spacing of all intersecting public ways and other accesses that will be full movement, or have the potential for signalization, is one-half mile intervals and based upon section lines where feasible. Exceptions to this one-half mile standard may be permitted when the proposal documents that there are no other reasonable alternatives to achieve a one-half mile interval, or that an additional signal is necessary. The applicant must establish to the Department's satisfaction that, a) there are no other reasonable site design, access or circulation alternatives eliminating the need for the signal, and b) there is a proven public necessity for the intersection, and c) a traffic signal study and traffic analysis acceptable to the Department is completed. The study must show that the proposal is able to achieve a signal progression analysis that indicates a good progression of 35 percent efficiency or better, or must be able to show that it does not degrade the existing signal progression. Code criteria for access spacing, 20th year left turn storage capacity, and roadway design must also be met. In selecting locations for traffic signals, and for doing analysis, preference shall be given to public ways that meet or may be reasonably expected to meet signal warrants in the foreseeable future.
- (4) Where topography or other existing conditions make one-half mile intervals inappropriate or not feasible, location of the access shall be determined with consideration given to topography, established property ownerships, unique physical limitations and or unavoidable or pre-existing historical land use patterns and physical design constraints. The final location should serve as many properties and interests as possible to reduce the need for additional direct access to the state highway.
- (5) Left turns in (3/4 movement) may be allowed at accesses if the addition of left turns will improve operation at an adjacent full-movement intersection, and meet appropriate design criteria, and significant operational or safety problems would not occur. Left turns should be prohibited if a non-traversable median is already established and the proposed opening in the median does not provide the general public any significant benefits to highway traffic operations and safety or would be counter to the purpose of the median.
- (6) Additional right turn only access shall be allowed where required acceleration and deceleration lanes can be provided, would relieve an identified congestion condition on the local street or road system, would not be detrimental to the safety and operation of the highway, would be in compliance with Code Section Four design standards, and the additional access would not knowingly cause a hardship to an adjacent property or interfere with the location, planning, and operation of the general street system.

Auxiliary Lane Requirements

- (7) Auxiliary turn lanes shall be installed according to the criteria below.

- (a) A left turn deceleration lane and taper with storage length is required for any access with a projected peak hour ingress turning volume greater than 10 vph. The taper length will be included within the required deceleration length.
 - (b) A right turn deceleration lane and taper is required for any access with a projected peak hour ingress turning volume greater than 25 vph. The taper length will be included within the required deceleration length.
 - (c) Right turn acceleration lane and taper is required for any access with a projected peak hour right turning volume greater than 50 vph when the posted speed on the highway is greater than 40 mph. The taper length will be included within the required acceleration length. A right turn acceleration lane may also be required at signalized intersections if a free-right turn is needed to maintain an appropriate level of service.
 - (d) Right turn deceleration and acceleration lanes are generally not required on roadways with three or more travel lanes in the direction of the right turn except as provided in subsection 3.5.
 - (e) A left turn acceleration lane may be required if it would be a benefit to the safety and operation of the roadway or as determined by subsection 3.5. A left turn acceleration lane is generally not required where: the posted speed is less than 45 mph, or the intersection is signalized, or the acceleration lane would interfere with the left turn ingress movements to any other access.
- (8) No additional access rights shall accrue upon the splitting or dividing of existing parcels of land or contiguous parcels under or previously under the same ownership or controlling interest. All access to newly created properties shall be provided internally from any existing access or a new access determined by Code design standards or by permit application and consistent with this subsection.
- (9) No traffic signal location shall be authorized without the completion of an acceptable analysis of traffic signal system operation, design and safety as well as meeting M.U.T.C.D. signal warrants. The desirable spacing standard for traffic signals is one-half mile. Any access which would reduce the optimum highway bandwidth if a traffic signal were installed shall be limited by the criteria of this subsection.
- (10) When an existing access meets the warrants for a traffic signal as defined in the M.U.T.C.D., and the location does not meet the requirements of this subsection, the access may be reconstructed to eliminate or reduce the traffic movements that cause the traffic signal warrant to be met, and the access brought into conformance with the criteria of this subsection. A raised median may be required. Closure may be required if alternative reasonable access is available.
- (11) With the exception of frontage roads, any new non-rural highway alignment or newly designated roadway, shall be considered no less than an access category NR-A highway until the Commission has specifically assigned an access category.
- (12) Where frontage and service roads are present, unless otherwise specifically categorized, a category NR-A shall be assumed for all at-grade roadway sections within Department right-of-way between frontage and service roads and the main roadway.

3.11 Category NR-B - Non-Rural Arterial

Functional Characteristics and Category Assignment Criteria

- (1) This category is appropriate for use on non-rural highways that have the capacity for moderate travel speeds and relatively moderate to high traffic volumes over medium and short travel distances providing for intercity, intracity and intercommunity travel needs. These routes are generally not of regional, state or national significance. This category is typically assigned within developed portions of cities and towns where there is established roadside development making the assignment of a higher functional category unrealistic. This category is also appropriate for short sections of regional highway passing through rural communities that may be located along route of regional, state and national significance where assignment to a higher category is unrealistic. While this category provides service to through traffic movements, it allows more direct access to occur.

Access Granting Criteria including Category Related Access Location, Operation and Design Standards

- (2) When application is made, one access shall be granted to each parcel, if it does not create safety or operational problems. The access will provide, as a minimum, for right turns only. The access may have left turns in (3/4 movement) if the addition of left turns will improve operation at an adjacent full-movement intersection and meet appropriate design standards, unless significant operational or safety problems would occur. Where it is shown that the location will be able to meet appropriate design criteria, full-movement access shall be granted at one-half mile spacing, or where a signal progression analysis indicates good progression of 30 percent efficiency or better, or does not degrade the existing signal progression. Where the proposal includes a traffic signal, the applicant must establish that, a) there are no other reasonable site design, access or circulation alternatives eliminating the need for the signal, b) there is a public necessity for the intersection, and c) a traffic signal study and traffic analysis acceptable to the Department is completed.
- (3) Additional right-turn-only access shall be allowed where required auxiliary lanes can be provided. Additional right-turn-only access may be allowed when it would relieve an identified congestion condition on the local street or road system which cannot be improved, and the parcel size or trip generation potential requires additional access to maintain good highway traffic and land use design. To obtain the additional access the applicant must also show that the additional access would not knowingly cause a hardship to an adjacent property or interfere with the location, planning, and operation of the general street system.

Auxiliary Lane Requirements

- (4) Auxiliary turn lanes shall be installed according to the criteria below.
 - (a) A left turn lane with storage length plus taper is required for any access with a projected peak hour left ingress turning volume greater than 25 vph. If the posted speed is greater than 40 mph, a deceleration lane and taper is required for any access with a projected peak hour left ingress turning volume greater than 10 vph. The taper length will be included within the deceleration length.
 - (b) A right turn lane with storage length plus taper is required for any access with a projected peak hour right ingress turning volume greater than 50 vph. If the posted speed is greater than 40 mph, a right turn deceleration lane and taper is required for any access with a projected peak hour right ingress turning volume greater than 25 vph. The taper length will be included within the deceleration length.
 - (c) The issuing authority or Department may require an auxiliary lane when it is specifically identified and documented that the lane is necessary to prevent or correct an operational or safety condition or as determined by subsection 3.5.

(d) An acceleration lane is generally not required except as may be determined by subsection 3.5.

(5) When an existing access meets the warrants for a traffic signal as defined in the M.U.T.C.D., and the location does not meet the requirements of this subsection, the access may be reconstructed to eliminate or reduce the traffic movements that cause the traffic signal warrant to be met, and the access brought into conformance with the criteria of this subsection. A raised median may be required. Closure may be required if alternative reasonable access is available.

3.12 Category NR-C - Non-Rural Arterial

Functional Characteristics and Category Assignment Criteria

(1) This category is appropriate for use on non-rural highways that have the capacity for low to moderate travel speeds and relatively moderate volumes over medium and short travel distances providing for intercity, intracity and intercommunity travel needs. These routes are not of regional, state or national significance. This category is typically assigned where there is extensive established roadside development and street systems such as a 'downtown' area, making the assignment of a higher category unrealistic. This category provides a reasonable balance between direct access and mobility needs.

Access Granting Criteria including Category Related Access Location, Operation and Design Standards

(2) When application is made, one access shall be granted to each parcel if it does not create a significant safety problem or significantly degrade operation. The access may operate as a full-movement unsignalized access unless there is an established non-traversable median, or a safety or traffic operation problem is identified.

(3) Additional access shall be granted if the additional access would not knowingly cause a hardship to an adjacent property or interfere with the location, planning, and operation of the general street system, and would be in compliance with Code design standards, and the applicant establishes that an additional access is necessary for the safe and efficient use of the property. Where the property abuts or has primary access to a lesser function road or an internal street system or by way of dedicated rights-of-way or easements, any access to the state highway shall be considered as an additional access.

Auxiliary Lane Requirements

(4) Auxiliary turn lanes shall be installed according to the criteria below.

(a) A left turn lane with storage length plus taper length is required for any access with a projected peak hour left ingress turning volume greater than 25 vph. If the posted speed is greater than 40 mph, a deceleration lane and taper is required for any access with a projected peak hour left ingress turning volume greater than 10 vph. The taper length will be included within the deceleration length.

(b) A right turn lane with storage length plus taper length is required for any access with a projected peak hour right ingress turning volume greater than 50 vph. If the posted speed is greater than 40 mph, a right turn deceleration lane and taper is required for any access with a projected peak hour right ingress turning volume greater than 25 vph. The taper length will be included within the deceleration length.

(c) The issuing authority or Department may require an auxiliary lane when it is specifically identified and documented that the lane is necessary to prevent or correct an operational or safety condition, or as determined by section 3.5.

- (5) For residential property, if the property abuts or has primary access to a lower classification street or road by way of an internal street or road system or dedicated rights-of-way or easements, any driveway to the state highway shall be considered as an additional access.
- (6) When a proposed access would meet the warrants for a traffic signal as defined in the M.U.T.C.D., and the location does not meet the requirements of this subsection, the access may be reconstructed to eliminate or reduce the traffic movements that cause the traffic signal warrant to be met, and the access brought into conformance with the criteria of this subsection. A raised median may be required.
- (7) Minimum spacing between traffic signals shall be that which is necessary for the safe operation, capacity, and proper design of the signal and adjacent accesses. The location shall be consistent with current signal progression efficiency and cause no degradation. Preference in traffic signal location, timing and operation shall be given to highways and cross streets of a higher access category or function. No traffic signal shall be authorized without the completion of an analysis of traffic signal system operation, design, and safety as well as meeting M.U.T.C.D. signal warrants.

3.13 Category F-R - Frontage Road

Functional Characteristics and Category Assignment Criteria

- (1) Category F-R shall be assigned only to roadways that are designated as frontage or service roads where there is no intended purpose of providing for long distance traffic movements. Category F-R may be assigned for high speed rural frontage roads. Access needs will take priority over through traffic movements without compromising the public health, welfare, or safety. Providing reasonable and safe access to abutting property is the primary purpose of this access category. At the request of the local authority, the Commission may in accordance with subsection 2.2, assign any frontage or service road to a higher access category when desirable to meet local transportation plans and needs.

Access Granting Criteria including Category Related Access Location, Operation and Design Standards

- (2) When application is made, one access shall be granted to each parcel if it does not create a significant safety problem or significantly degrade operation. The access may operate as a full-movement unsignalized access unless there is an established restrictive median, or a safety or operations problem is identified. The location shall also be consistent with current signal progression efficiency and cause no degradation
- (3) Additional access will be granted if the additional access would not knowingly cause a hardship to an adjacent property or interfere with the location, planning, and operation of the general street system, and would be in compliance with Code design standards. Additional access will be granted if the size or trip generation potential of the parcel of land requires additional access to maintain good design.

Auxiliary Lane Requirements

- (4) Auxiliary turn lanes shall be installed on category F-R roadways according to the criteria below:
 - (a) A left turn lane with storage length plus taper length is required for any access with a projected peak hour left ingress turning volume greater than 25 vph. If the posted speed is greater than 40 mph, a deceleration lane and taper is required for any access with a projected peak hour left ingress turning volume greater than 10 vph. The taper length will be included within the deceleration length.

- (b) A right turn lane with storage length plus taper length is required for any access with a projected peak hour right ingress turning volume greater than 50 vph. If the posted speed is greater than 40 mph, a right turn deceleration lane with taper is required for any access with a projected peak hour right ingress turning volume greater than 25 vph. The taper length will be included within the deceleration length.
 - (c) A right turn acceleration lane with taper is required for any access with a projected peak hour right turning volume greater than 50 vph when the posted speed on the highway is greater than 40 mph and the highway has only one lane for through traffic in the direction of the right turn. A right turn acceleration lane is not required on multi-lane highways of this category. The taper length will be included within the required acceleration length.
 - (d) A left turn acceleration lane with transition taper may be required if it would be a benefit to the safety and operation of the roadway or as determined by subsection 3.5. A left turn acceleration lane is generally not required where: the posted speed is less than 45 mph, or the intersection is signalized, or the acceleration lane would interfere with the left turn ingress movements to any other access.
- (5) Where the end of the frontage road will proceed directly into the property or public way, auxiliary lanes may not be necessary. If the frontage road proceeds into private property, the applicant may be required to provide a cul-de-sac or similar design function that will provide for the safe and convenient u-turns of vehicles within public right-of-way.
- (6) Minimum spacing between traffic signals shall be that which is necessary for the safe operation, capacity, and proper design of the signal and adjacent accesses. Preference in traffic signal location, timing and operation shall be given to highways and cross streets of a higher access category or function. No traffic signal shall be authorized without the completion of an analysis of traffic signal system operation, design, and safety as well as meeting M.U.T.C.D. signal warrants.

Section Four Design Standards and Specifications

4.1 Purpose

- (1) The Department has developed the following design and construction standards and specifications for application in Code decisions to protect the public health, safety, and welfare; maintain smooth traffic flow; maintain highway right-of-way drainage; and protect the functional level of public highways.

4.2 Use of Section Four

- (1) If the issuing authority determines that an application for access meets the requirements of Section Three, Section Four shall be used to precisely locate, design and construct the access within the criteria set forth in Section Three. When a local government is the issuing authority and it has established by ordinance or resolution more stringent design standards than required in this section, the local standards may govern where applied by the local authority and is determined acceptable to the Department. All construction materials, techniques and processes shall be in conformance with the specifications on the permit, and shall not be inconsistent with Department standard specifications for road construction. A proposal for access may not presume a lower posted speed limit than currently posted or request a lower speed limit in order to accommodate the access unless specifically directed in writing by the Department.
- (2) If an access application meets Section Three criteria and is unable to comply with Section Four criteria, the access permit should be denied unless a design waiver is authorized pursuant to Section Four. When the access permit has been issued and later design development does not

meet Section Four, then the Notice to Proceed cannot be issued unless a design waiver is approved.

- (3) This section relies on general design techniques. The use of more exact geometric engineering standards and methods is permissible provided the design meets Code purposes, does not violate Code standards, and is based upon desirable nationally accepted standards and is determined acceptable to the Department.
- (4) Speed, as used in this section, refers to the posted legal speed limit at the access location at the time of permit approval except as adjusted by 4.8(1)(e). A higher speed for access design shall be used if the section of highway is presently being redesigned or reconstructed to a higher speed or an approved access control plan requires a higher speed. Where a traffic signal will be installed as part of the access construction, the access design and the anticipated posted speed limit after signal installation may be used for the overall access design at the discretion of the Department.
- (6) When determining the distance between accesses, the point of tangency shall be used where a radius is present, or the beginning of the curb cut. More complex accesses including ramp connections shall be measured from the beginning of the radii along the state roadway or between 2 points determined by the Department.

4.3 Sight Distance

- (1) Permits shall not be issued that include any design element or allow any turning movements where the sight distance is not adequate to allow the safe movement of a motorist using or passing the access. The permittee shall maintain adequate, unobstructed sight distance in both directions from the access. This sight distance shall be the distance necessary according to the posted speed of the highway using the tables below. Any potentially obstructing objects such as but not limited to advertising signs, structures, trees, and bushes, shall be designed, placed and maintained at a height not to interfere with the sight distance needed by any vehicle using the access. Reconstruction of the horizontal and vertical curvature along the roadway and side slopes adjacent to the roadway may be necessary to increase sight distances to meet the requirements of tables 4-1 and 4-2.

(2) Sight Distance Along Highway.

- (a) Table 4 - 1 shall be used to determine the required horizontal and vertical sight distance necessary as measured from the vehicle traveling on the highway to the access. The design sight distance figures shall be used unless a design waiver is issued in accordance with section 4.12. However, in no case shall the sight distance used be less than the minimum sight distance set forth in table 4-1 and adjusted for grade as required by table 4-4.

Table 4 - 1 Sight Distance Along Highway

Posted speed in MPH	25	30	35	40	45	50	55	60	65	70
Design sight distance (in feet)	150	200	250	325	400	475	550	650	725	850
Minimum sight distance (in feet)	150	200	225	275	325	400	450	525	550	625

- (b) For calculating table 4 - 1, sight distance at the proposed access location, a height of 3.5 feet shall be used for the driver's eyes of a vehicle on the highway approaching the access location. The driver's eyes shall be assumed to be at the centerline of the inside lane (inside with respect to the curve) for measurement purposes. A height of 4.25 feet shall be used for a vehicle assumed to be on the centerline of the access five feet back from the edge of the roadway.

- (c) The lengths shown in table 4-1 shall be adjusted for any grade of three percent or greater using the figures set forth in table 4 - 4. Grade is the ratio of the change in elevation to the length of slope. Multiply the length required in table 4-1 by the appropriate factor in table 4-4.

(3) Entering Sight Distance

- (a) In addition to the sight distance necessary in accordance with section 4-3(2), it is also necessary to provide the entering vehicle adequate sight distance in order to enter or cross the highway. Table 4-2 shall be used to establish the minimum sight distance necessary for the entering vehicle. These lengths shall be adjusted for any grade of three percent or greater using table 4-4. The vehicle used to determine the entering sight distance necessary shall be selected from table 4-3.
- (b) For calculating table 4-2 sight distance, a height of 3.5 feet shall be used for the driver's eyes at the access location and a height of 4.25 feet for the oncoming vehicle. The entering driver's eyes shall be assumed to be 10 feet back from the edge of the roadway.
- (c) If there is no median or if the median is too narrow to safely store a left turning or crossing vehicle, a 20 foot minimum is necessary for passenger cars, both directions shall be considered from the access location. If the median can safely store the turning or crossing vehicle, then the sight distance shall be calculated assuming a two stop condition. The vehicle shall be assumed to stop once at the outside edge of the outside lane and again within the median. Each one-way roadway direction shall be considered separately.

Table 4 - 2: Entering Sight Distance (in feet)

Vehicle expected to enter or cross highway as determined from table 4-3	Posted Speed of Roadway in MPH									
	25	30	35	40	45	50	55	60	65	70
Two Lane Roadway										
Passenger Cars, Pickup Trucks	250	300	350	400	450	500	550	600	650	700
Single Unit Trucks Over 10,000 lb GVW	325	390	455	520	585	650	715	780	845	910
Multi-Unit Trucks	425	510	595	680	765	850	935	1020	1105	1190
Four Lane Roadway										
Passenger Cars, Pickup Trucks	300	360	420	480	540	600	660	720	780	840
Single Unit Trucks Over 10,000 lb GVW	375	450	525	600	675	750	825	900	975	1050
Multi-Unit Trucks	500	600	700	800	900	1000	1100	1200	1300	1400
Six Lane Roadway										
Passenger Cars, Pickup Trucks	325	390	455	520	585	650	715	780	845	910
Single Unit Trucks Over 10,000 lb GVW	425	510	595	680	765	850	935	1020	1105	1190
Multi-Unit Trucks	525	630	735	840	945	1050	1155	1260	1365	1470

Table 4 - 3: Design Vehicle Selection

Land Use(s) Served by Access	Design Vehicle(s) to be Used for Sight Distance Calculations for table 4 - 2
Residential (a non-school bus route)	Passenger Cars, Pickup Trucks
If access is a part of any school bus route regardless of land use	No less than Single Unit Trucks
Office	Single Unit Trucks
Recreational	Single Unit Trucks
Commercial/Retail	Multi-Unit Trucks*
Industrial	Multi-Unit Trucks*
Municipal Streets & County Roads	Multi-Unit Trucks*
Agricultural Field Approaches, < 1 per day	Single Unit Trucks
*If less than 2 multi-unit truck trips per day (average), use single-unit truck	

Table 4 - 4: Stopping and Deceleration Adjustment Factors for Highway Grade

3% to 4.9% Upgrade, Use 0.9	3% to 4.9% Downgrade, Use 1.2
5% to 7% Upgrade, Use 0.8	5% to 7% Downgrade, Use 1.35

4.4 Access Spacing

- (1) When access is allowed in accordance with Section Three of the Code, each access should be separated at a minimum by a distance equal to the design sight distance values in table 4 - 1. When speed change lanes are present, or will be needed in the future, it is desirable that the accesses be separated by a sufficient distance so that the speed change lanes including transition tapers do not overlap or an equivalent distance if speed change lanes are not yet built. Access should not be permitted within an auxiliary lane, taper or ramp.

4.5 Access Width

- (1) Access width is the actual traveled portion of the access as it extends away from the roadway. Access width for any type access without curbs shall be measured exclusive of the radii or flares. Width of an access with a curb return entrance and driveways with curb cuts, shall be measured exclusive of the flared sections, transitions, curb and gutter. The width of any non-traversable median is not counted as part of the access width. In measuring access width, only the travel portion of the access is measured.
- (2) Sixteen to 30 feet of width shall be used for any two-way access when the single unit vehicle peak hour volume does not exceed five except as noted in subsection 4.5(3).
- (3) Twenty-five to 40 feet of width shall be provided for any two-way access when any one or more of the following apply to the access:
- (a) Peak hour vehicle volume of the access exceeds five.
 - (b) Multi-unit vehicles are intended to use the access.
 - (c) Single unit vehicles in excess of 30 feet in length will use the access.
 - (d) Special vehicles using the access exceed 16 feet in width.
- (4) A one-way access shall have a width of 16 feet to 18 feet. If two one-way approaches (one-way in, one-way out) are adjacent to each other, they shall be divided by a non-traversable median of at

least four feet but no more than 25 feet wide and treated as one access. The access median shall be signed and clearly visible.

- (5) When a public street, road, highway or any access intended to become a public way intersects with a state highway, the long term traffic projections and consideration of the modal use of the public way shall be used to select an appropriate access width, subject to the approval of the Department. It is recommended that no two-way public roadway access in excess of 10 D.H.V. be less than 36 feet in width at the intersection exclusive of the radii.
- (6) Where a private access will have high traffic volumes, the access may be designed with curb returns and at a width and design sufficient to accommodate the traffic volumes as determined by the issuing authority subject to approval of the Department.

4.6 Access Radii

- (1) Except for curb cuts, accesses shall have 20 foot radii unless criteria below requires otherwise.
- (2) The equivalent turning radii of the access shall accommodate the turning radius of the largest vehicle using the access on a daily basis. Where paved shoulders are present, the radius is measured to the edge of the closest lane. Where roadway shoulders are not present, field and residential accesses should have 25 foot radii.
- (3) For any access where multi-unit vehicles, or single unit vehicles exceeding 30 feet in length, are intended to use the access on a daily basis, the radii of the access should be determined using the minimum turning path for the larger vehicle. It is desirable to use equivalent three-centered compound curves or spiral curves rather than simple radii when designing for larger vehicles. The curves used should ensure safe turning movements without encroachment onto other highway travel lanes.
- (4) If the frequency of multi-unit vehicles or single unit vehicles over 30 feet in length is such that two such vehicles may be reasonably anticipated to use the access at the same time, one entering and one exiting, radii should be adequate to accommodate both vehicles with no turning conflicts and without undue slowing.
- (5) Where curbs are present, a curb cut style driveway will normally be required. Radius curb returns may be used when determined to be necessary, are not inconsistent with existing or planned conditions, and acceptable to the local authority. The issuing authority or Department shall determine if a curb cut or radius curb returns are required in accordance with existing or planned conditions.
- (6) When a public street, road, or highway or any access intended to become a public way intersects with a state highway, the design criteria of the local government and the Department shall be used to select appropriate radii, corner and intersection design, subject to approval by the Department. The final design should not be less than the minimums contained in the Code.
- (7) Where there are numerous accesses, such as along an established municipal street or road, it may be desirable to reduce the radii in order to improve visual and physical separation of accesses. Where feasible or required by the Code, access should be combined or closed to reduce the frequency of accesses and increase the spacing between accesses.
- (8) To minimize pedestrian conflict and total access width at the roadway edge, radii shall not be constructed larger than required to accommodate the volume and types of vehicles using the access on a regular basis.

- (9) Where access channelization islands are installed, a 70 foot radius may be required for the channel lane. Traffic islands should be 100 square feet in size or larger. The minimum size without a waiver is 50 square feet. All islands must have tapered offsets beginning at 6 feet at the approach nose and tapering to 3 feet, or as approved by the Department, from the edge of the highway traveled way to face of curb.

4.7 Access Surfacing

- (1) Surfacing material may include approved grades of gravel, concrete pavement, and bituminous pavement. Hard surfacing includes either concrete or bituminous pavements. Roadway and access surfacing treatments shall conform to Department or local authority adopted specifications which ever is greater.
- (2) The access shall be surfaced upon completion of earthwork construction and prior to being used. At locations where new hard surface pavement is to abut existing pavement, the existing pavement shall be saw cut and removed a minimum of one foot back from the existing edge for bituminous, or until an acceptable existing cross slope is achieved. A delay in installation of hot bituminous pavement due to seasonal restrictions may be allowed provided adequate temporary gravel surfacing is substituted.
- (3) The access shall be surfaced at least from the highway roadway to the right-of-way line. Any access with greater than 5 AADT shall have a hard surface pavement for a minimum distance of 4 feet from the traveled way. Any access with greater than 20 AADT shall have a hard surface pavement for a minimum distance of 20 feet from the traveled way. Any access with greater than 100 AADT shall have a hard surface pavement for a minimum distance of 50 feet from the traveled way. Any access requiring a turn lane shall have a hard surface pavement for a minimum distance of 50 feet from the traveled way.
- (4) Surfacing material and depth shall be specified and installed according to the Department's standard design specifications and the conditions and future use of the access and the highway. Aggregate base course Class 6 or equivalent may be permitted for individual residential access or field entrances where conditions allow, and where curbs are not required.
- (5) Off roadway surfacing improvements shall not be allowed within the highway right-of-way unless approved by the Department and a concrete curb or other physical separator such as a drainage ditch is constructed and maintained to limit access movements to permitted locations.
- (6) A two inch overlay of the entire width of the roadway may be required when determined by the Department to be necessary. The Department will look at the current condition of the roadway and the additional impacts to surface quality and roadway strength given the access impacts, where through lanes are redirected, where restriping is necessary, where the centerline of the roadway is shifted, where it is necessary to reset the high point in the roadway cross section that determines the direction of surface drainage, or to allow for the regrade of the surface to meet surface drainage requirements.

4.8 Speed Change Lanes

(1) General Criteria for Speed Change Lanes

- (a) The warrants and elements for the construction of speed change lanes is set forth in Section Three. When speed change lanes are required, they shall be constructed in accordance with this subsection and other applicable parts of Section Four.
- (b) When public safety so requires due to site specific conditions, such as sight distance, a turn lane may be required even though the criteria in Section Three are not met.

- (c) Where there are three or more through lanes in the direction of travel, the Department shall not require a right turn acceleration and or deceleration lane unless it is determined to be necessary due to high traffic volumes or when a significant roadway capacity, operational or geometric safety problem will exist. Each case shall be reviewed independently and a decision made based upon site specific conditions. Strong consideration shall be given to the opinion of the local municipality and their concerns regarding the anticipated and desirable future cross section of the highway.
- (d) Where two accesses have speed change lanes that overlap, or the ending points of the speed change lanes have less than 300 feet or one-half their length of separation (whichever is shorter) and a significant structure or topographical feature does not preclude widening, a continuous auxiliary lane shall be established between the accesses to improve roadway consistency, safety, and to maintain edge of pavement continuity.
- (e) If the design of the access is within two different speed zones, the design of a speed change lane shall be based upon the applicable speed limit. Generally, the entering posted speed is used for the deceleration lane, and the posted speed at the end of the acceleration lane is applicable.
- (f) Where there are higher left turning volumes, safety or traffic operations necessitate, a double left turn may be required.
- (g) A speed change lane for acceleration and merging onto travel lanes should be parallel and immediately adjacent to the traveled way for its entire acceleration and transition taper length. Where the acceleration length is not parallel to the traveled way, there shall be a parallel full width auxiliary lane based upon posted speed. The parallel length should be no shorter than a standard calculated merge distance.
- (h) If restrictive topography allows only one auxiliary lane, normally a left turn deceleration lane is given first priority. Where a left turn is installed and or the travel lanes redirected, an overlay of pavement may be required by section 4.7.

Figure 4 - 1: Information Guide to Basic Auxiliary Lane Elements

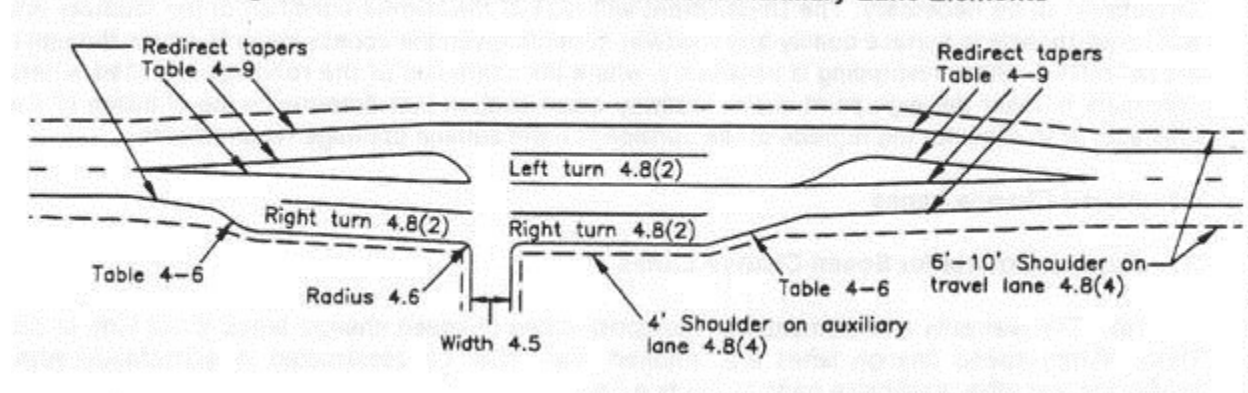

(2) Necessary Components Determining Speed Change Lane Length

- (a) The components of an auxiliary turn lane consists of transition taper, full width auxiliary lane, and storage length. The use of these three components varies according to the assigned access category and to some extent, site specific conditions. Table 4 - 5 summarizes the components of speed change lanes when such lanes are required by the category standards. Read the category requirements and subsection 3.5 to determine if any speed change lanes are required. Table 4 - 5 is provided to be used in conjunction with table 4 - 6.

Table 4 - 5: Components of Speed Change Lane Length

Access Category	Left turn deceleration lane	Right turn deceleration lane	Acceleration lane
F-W	Design must meet federal interstate standards, and no less than E-X		
E-X	taper + decel.length+storage	taper + decel. length	accel.length + taper
R-A	* decel. length + storage	* decel. length	* accel. length
R-B	* decel. length + storage	* decel. length	* accel. length
NR-A	* decel. length + storage	* decel. length	* accel. length
NR-B	taper + storage	taper + storage	* accel. length
NR-B >40mph	* decel. length	* decel. length	* accel. length
NR-C	taper + storage	taper + storage	* accel. length
NR-C >40mph	* decel. length	* decel. length	* accel. length
F-R	taper + storage	taper + storage	* accel. length
F-R >40mph	* decel. length	* decel. length	* accel. length

* Taper length is included within stated accel. or decel. length.

(b) To determine the required acceleration, deceleration lane and transition taper length in table 4-5, use the criteria provided in table 4 - 6.

Table 4 - 6: Design Criteria for Acceleration and Deceleration Lanes

Posted Speed Limit in MPH	25	30	35	40	45	50	55	60	65	70
Deceleration Length in feet	180	250	310	370	435	500	600	700	800	900
Acceleration Length in feet	N/A	190	270	380	550	760	960	1170	1380	1590
Transition Taper Ratio	7.5:1	8:1	10:1	12:1	13.5:1	15:1	18.5:1	25:1	25:1	25:1

(c) Deceleration lengths shown in table 4-6, shall be adjusted for any grade of three percent or more using the factors shown in table 4-4. Acceleration lengths shown in table 4-6, shall be adjusted for any grade of three percent or more using the factors shown in table 4-7. Where only the transition taper and storage length is provided, the length of the lane including transition taper shall be adjusted for grade using tables 4-4 and 4-7.

(d) When physical or legal constraints necessitate reducing part of the deceleration length, the transition taper length will be reduced first, then the deceleration length. This minimum design criterion shall be used without waiver approval only on highways posted below 45 MPH when, (1) the requirements of table 4 - 6 are not feasible, and (2) the access category is not a F-W or E-X, or (3) the highway has in that section, four or more intersections per mile per side, and there is heightened driver expectancy of vehicle speed changes, turning movements and weaving movements along that section of highway. If the above reduction criteria are not sufficient for shortening of the length due to the constraint, then any necessary additional shortening of the lane can only be done by the design waiver procedure.

Table 4 - 7: Grade Adjustment Factors For Acceleration Lanes

Posted Speed MPH	25 to 45	50	55	60	65	70
3 to 4.9% Upgrade	1.3	1.4	1.5	1.5	1.7	1.8
5 to 7% Upgrade	1.5	1.8	2.0	2.3	2.5	3.0
3 to 4.9% Downgrade	0.7	0.65	0.65	0.6	0.6	0.6
5 to 7% Downgrade	0.6	0.55	0.55	0.5	0.5	0.5

- (e) Where noted by table 4 - 5, or the auxiliary lane requirements of the category description in Section Three, speed change lane storage lengths shall be included in the design as provided in table 4-8.

Table 4 - 8: Storage Lengths

Turning Vehicles Per Peak Hour	below 30	30	60	100	200	300
Required Lane Length in Feet	25	40	50	100	200	300

- (f) Table 4-8 is based on automobile lengths. To allow for the impact of larger trucks, buses and recreational vehicles, "passenger car equivalents" shall be determined. Use a passenger car equivalent of 3 for each bus and all trucks and combinations of 40 feet in length or longer. Use a passenger car equivalent of 2 for each vehicle or combination at or over 20 feet in length but less than 40 feet.

(3) Speed Change Lane Width

- (a) Speed change lanes shall normally be 12 feet wide exclusive of gutter pan or shoulder. If existing through travel lanes are less than 12 feet wide and if local government standards concur, an 11 foot width may be used. Where necessary, a minimum of 10 feet of width is allowable on highways with a posted speed of less than 45 MPH and less than 10 percent trucks. Speed change lanes should be a minimum of 11 feet wide on highways with a posted speed above 40 MPH, or where percentage of large trucks using the lane exceeds 9 percent.

(4) Shoulder Width Along Speed Change Lanes Where Curbs are not Present

- (a) When necessary to redirect the traveled way or install a speed change lane, a paved shoulder adjacent to the lane shall be provided where no curb and gutter is present.
- (b) Shoulders adjacent to the traveled way should be a minimum of six feet in width but no less than the width of the current shoulder. Shoulders adjacent to the traveled way should not be less than 10 feet in width on any highway designated as part of the National Highway System.
- (c) Shoulders adjacent to a speed change lane shall be four feet in width.

(5) Taper Designs

- (a) The length of the transition taper for the auxiliary lane shall be determined according to the values given in table 4 - 6, which are the ratio of transition taper length to speed change lane width. The length of a transition taper is calculated by multiplying the width of the speed change lane by the ratio value associated with the posted speed in table 4 - 6. A 25 MPH zone and a 12 foot wide speed change lane at a 7.5:1 ratio, requires a 90 foot transition taper. The beginning and ending point of all tapers shall be rounded.
- (b) It is recommended that bay tapers be used (asymmetrical reverse curves) for deceleration transition tapers and that straight transition tapers be avoided at speeds above 40, and where a vertical

cresting, or horizontal curve is present, substituting an immediate bay taper and auxiliary lane striping to reduce drifting of the through vehicles into the deceleration lane. Where horizontal or crest vertical curves exist, the Department may require the deceleration transition taper to begin with an immediate asymmetrical reverse curve bay taper of 1/3L then 2/3L with the remaining required transition taper length at full lane width.

- (c) Partial tangent transition tapers, symmetrical reverse curve tapers, or asymmetrical reverse curve tapers may be used for transition taper design provided a radius of at least 150 feet is used in curve calculations.
- (d) Where it is necessary to establish a left turn lane or median island, or otherwise redirect the vehicles on the traveled way, redirect tapers required for redirecting through travel lanes shall be installed according to table 4 - 9. If the use of table 4 - 9 would create a horizontal curve design deficiency for the through movement, the horizontal curve shall be corrected in addition to the use of redirect tapers. A redirect taper should normally be a straight taper with the beginning and ending points rounded.

Table 4 - 9: Redirect Tapers for Through Lanes

Posted Speed in MPH	30 or less	35	40	45	50	55	60	65	70
Straight Taper Ratio	15:1	20:1	30:1	45:1	50:1	55:1	60:1	65:1	70:1

(6) Median Design for Turn Lane Installation

- (a) Where a single left turn lane is necessary, a median area of 16 feet shall be provided. The median area will normally consist of a 12 foot turn lane and a 4 foot painted separator. Where a median area does not exist or where the painted median area is less than 16 feet in width and a left turn lane is required, the roadway shall be widened sufficiently in order to provide a median of at least 16 feet in width to accommodate the left turn lane. If a barrier median is necessary, the median area should consist of a 12 foot lane exclusive of gutter, and a minimum 6 foot raised median divider. Existing raised or other non-traversable medians shall not have new openings unless a study analyzing all related traffic and safety issues is completed to the satisfaction of the Department and the Department issues a written determination why the median opening is acceptable.
- (b) Where there is a median of 16 feet or greater in width, the existing width may be used. Where the existing median is a non-traversable barrier design, any new median construction shall also be of similar barrier design unless otherwise instructed by the Department. These design features may be modified at the discretion of the Department where physical constraints, curbs, sidewalks, structures, and lack of available right-of-way restricts installation.
- (c) Where it is necessary to widen a highway for a median and public right-of-way is made available, the highway should be widened equally on both sides in order to maintain the existing highway centerline alignment.

4.9 Other Design Elements

- (1) When an access permit requires the horizontal or vertical realignment of travel lanes, the design of the roadway horizontal and vertical curves, superelevations, transitions, and related specifications, should be those necessary to meet the posted speed or advisory speed of the highway or the desirable overall design speed of the existing highway, or current design standards, whichever is reasonable given safety considerations, topography and costs. The design of the other elements of the highway shall be no less than the current highway design unless specifically directed by other sections of the Code.

- (2) For all curb cuts, the vertical curve from the traveled way into the access shall be the flattest curve that can be obtained. To prevent the center or overhang drag of a vehicle, with some allowance for vehicle load and bounce, crest vertical curves should not exceed a four inch hump in a 10-foot chord and sag vertical curves should not exceed a four inch depression in a 10-foot chord. For any access that is not a curb cut, including streets and private access using curb returns, the first 20 feet beyond the closest highway lane, including speed change lanes or the distance to the side drain, whichever is greater, shall slope down and away from the highway at a two percent grade to ensure proper drainage control. Exceptions may be made where steep topography, such as a mountain, makes this requirement very difficult to fulfill. The approved design must protect the highway from drainage flows. Valley gutters are not recommended. Where super elevations are present due to horizontal curves, drainage adjustments may be necessary at Department approval.
- (3) Within the right-of-way, maximum grades shall be limited to ten percent for low volume field and residential access. All other accesses shall be limited to a maximum of eight percent grade. Lesser grades may be required for drainage control purposes. Use of the right-of-way for access purposes should not preclude future roadway use of the public rights-of-way. The length of the access within the right-of-way should be minimized. Any access horizontal or vertical curve should be minimized within the right-of-way so as not to interfere with the future use, widening, reconstruction, or realignment of the highway within the right-of-way.
- (4) The horizontal axis of an access to the highway shall be at a right angle to the centerline of the highway and extend a minimum of 40 feet from the edge of the roadway or to the right-of-way line, whichever is greater. An angle between 90 and 60 degrees may be acceptable only if significant physical constraints require a skew angle less than 90 degrees and is approved by the issuing authority and the Department based upon site specific conditions. When horizontal curves are present, the issuing authority or Department may require a different access approach angle to improve entering sight distance.
- (5) Access specifications shall ensure that the access is designed and constructed in a manner that will encourage proper use by the motorist. Access limited to right turns may be requested to have a positive barrier such as a non-traversable median to prevent unauthorized turns either on the roadway or using the access. Channelized driveway islands may be required for turn restricted driveways when the driveway volume is predicted to exceed 100 DHV, no restrictive center median is in place or programmed to be constructed or it is likely that there will be frequent violations of the turn restrictions. Channelized driveway islands are normally not required when the driveway volume is lower and it is unlikely that there will be frequent violations of the turn restrictions.
- (6) An access that has a gate across it shall be designed so that the longest vehicle using it can clear the roadway when the gate is closed. If significant topographical features make this requirement infeasible, providing a wide shoulder for temporary standing while the gate is operated may be permitted or required.
- (7) The access shall be designed to facilitate the movement of vehicles from the highway to prevent the queuing of vehicles on the roadway. An access shall not be approved for parking areas that require backing maneuvers within state highway rights-of-way. All off-street parking areas must include on-site maneuvering areas and aisles to permit user vehicles to enter and exit the site in forward drive without hesitation other than as directed by official traffic control devices. The issuing authority may request the review of the parking lot layout and provide those terms and conditions and those design requirements necessary to ensure the safe use of the access.
- (8) Fill slopes and cut slopes shall be constructed either to (a) current Department minimum standards, or (b) to the slope of the existing highway near the access, whichever is determined appropriate by the Department and or the municipality if in an incorporated area. It is desirable that all side slopes have a slope of 6:1 for 12 feet. The minimum side slope template shall provide a 4:1 slope

for six feet, and then not steeper than 3:1 unless physically restricted. Tighter slopes may be permitted when proven necessary and approved by the appropriate Department Region Transportation Director. Soil preparation including top soil, seeding and mulching is required within the highway right-of-way on all disturbed areas not surfaced, and, those areas beyond the highway that may erode and send debris into the highway right-of-way. The Department or local municipality will provide minimum seed mixes, types and rates of seeding and preparation. The applicant may use an alternative mix and landscape plan if approved by the Department or municipality.

- (9) Access design shall provide for the safe and convenient movement of all highway right-of-way users and modes of transportation, including but not limited to pedestrians, bicyclists, transit and the physically challenged. Sidewalks may be required where deemed appropriate by the Department or when required by the local authority. Bike paths and a local commitment to maintain the facility, may be included in the access permit requirements upon request by the local authority.
- (10) In the event it becomes necessary to remove any right-of-way fence, the posts on either side of the entrance shall be securely braced with an approved end post before the fence is cut to prevent any slacking of the remaining fence. All right-of-way fence posts and wire removed are Department property and shall be turned over to a representative of the Department. Installation or removal of any right-of-way fence by the permittee shall not be inconsistent with right-of-way fence law in section 35-46-111, C.R.S.
- (11) Further details of access construction and design, including pavement thickness and specifications, curb design and specifications, roadway fill design and compaction, testing and inspection, and other specific details, may be provided by the Department.
- (12) Installation of any traffic control device necessary for the safe and proper operation and control of the access shall be required by the permit at the cost of the permittee. Arrangements to share costs with other property owners and interests who will benefit from the devices may be made by the permittee or local authority. Where the access may warrant signalization in the future, phasing of the installation may be required. All traffic control devices within the highway or other public right-of-way or access that serve the general public shall conform to the M.U.T.C.D.
- (13) Physical separation and delineation along a property frontage such as curb and gutter or fencing, may be required where necessary to ensure that access will be limited to permitted locations.
- (14) Careful consideration shall be given to the roadside clear zone. The permittee shall provide adequate clear zone to the extent feasible. The access permit may require that roadway hazards in the clear zone, such as fixed objects or steep embankments, be removed, reconstructed or shielded by a proper barrier. In urban areas with speeds of 40 MPH or less and vertical barrier curbs, a clear zone of at least 18 inches minimum should be provided beyond the face of curb. Where there is no curb in urban and rural areas and the speed is 40 MPH or less, a minimum seven foot clear zone should be provided. At speeds of 45 MPH or greater, the clear zone will vary from eight to 50 feet according to AADT, travel speeds, roadway and roadside design. To the extent practicable, every attempt will be made to adhere to standard clear zone practices and guidelines.
- (15) The permittee or contractor shall not disturb any survey monuments found in state highway right-of-way without specific Department authorization and direction. All costs associated with the relocation or reestablishing of a survey marker will be borne by the permittee. All survey procedures and minimum tolerances shall be in conformance with the Department Survey Manual and the "Manual of Instruction for the Survey of Public Lands of the United States" 1973, and section 38-53-101 et seq, C.R.S. Monuments shall conform to Department standard M-629-1. The equipment used in referencing or replacing monuments shall be able to produce the stated accuracies as specified by the owner of the monument.

4.10 Emergency access

- (1) An emergency access, when authorized in Section Three, shall have a minimum width to serve one-way traffic and may be less than 16 feet wide. The radii should be eliminated or reduced based upon the assumption that fire equipment may encroach on other travel lanes. The access profile can be individually designed without compromising drainage or vertical curve minimums. Surfacing shall be chosen to minimize its visibility while still providing sufficient strength. The emergency access shall have a suitable barrier to eliminate non-emergency use and barrier design usually based upon the standards of the local emergency services. The access shall not be open for non-emergency uses and shall be maintained by the permittee as a closed access except during emergencies. Any barrier shall not be in the state highway right-of-way and will not be maintained by the Department. The access shall remain closed at all times other than when in use for emergency purposes. The access should be signed for emergency services only.

4.11 Drainage

- (1) Each access shall be constructed in a manner that shall not cause water to enter onto the roadway or shoulder, and shall not interfere with the existing drainage system on the right-of-way or any adopted municipal system and drainage plan. The highway drainage system is for the protection of the state highway right-of-way, structures and appurtenances. It is not designed or intended to serve the drainage requirements of abutting or other properties beyond undeveloped historical flow. Drainage to the state highway right-of-way shall not exceed the undeveloped historical rate of flow.
- (2) The permittee shall provide, at their own expense, drainage structures for access which will become an integral part of the existing drainage system. The type, design, and condition of these structures shall meet the approval of the Department in unincorporated areas and the municipality and the Department in incorporated areas. Drainage pipe shall be a minimum of 18 inches in diameter or equivalent if not circular. Flared end sections or other protective end treatments may be required for culverts. Drainage structures under the access should extend beyond the access radius to accommodate flattened side slopes.
- (3) Where hydrological studies have been completed, the drainage shall be designed to handle at least the 2 ½ year storm for an underground system and a five year storm for side drains but not less than the existing drainage system. On larger systems and developments, the effects of a 100 year flood event should be assessed. Where the specific topography of the access site makes it likely that flooding in the highway and overtopping of the roadway may occur, the drainage study shall consider and the design reflect the 25 year flood for rural two lane highways, 50 year flood for four lane highways, and 100 year flood in all urban areas. Cross drainage shall be consistent with Department hydrology designs.
- (4) The use of controlled flow detention ponds shall be considered to control drainage flow from developed properties at or below historical flow rates. All drainage appurtenances required for detention and release shall be located and fully maintainable outside of the highway right-of-way. When curb and gutter is required, the drainage ditch should be eliminated by installing a storm sewer system. If a cross-pan is necessary, it shall be at least 8 to 10 feet wide and 8 inches thick. If a storm sewer system is available, it should be used, not a cross pan. All proposed drainage controls and designs require Department approval. The areas behind the curb and sidewalk shall have a down slope away from the roadway of at least one percent.

4.12 Design Waiver Procedures

- (1) If an applicant wishes to seek a waiver from the design standards of the Code, a request must be submitted as an attachment or addendum to a permit application form or provided with the request for the Notice to Proceed. Department Form No. 112 shall be used. The request for waiver shall state specific reasons why a waiver is necessary and appropriate and include

documentation to support such reasons. The request shall address the waiver criteria of this subsection. Waivers cannot be issued for procedural requirements. Separate waiver requests may be necessary where several waivers are necessary and where the waivers may be approved in whole or in part.

- (2) The applicant may supplement an application with a waiver request if the issuing authority determines that sufficient time remains in the review period to consider the waiver. If the issuing authority determines that it is in the public interest to do so, the issuing authority may supplement a permit application with a waiver.
- (3) In consideration of a waiver request, the issuing authority and Department shall determine if, (a) absent approval of the waiver request, there is exceptional and undue hardship on the applicant, and (b) a waiver would meet acceptable standards of practice for engineering, operation and safety. A waiver may not be contrary to the public interest, shall consider the orderly development plan of the local government, shall consider the function of the highway, shall consider the general design practices of the Department, and is subject to and limited by the purposes of the Code as set forth in subsection 1.2.
- (4) When a waiver is approved, the reasons for granting the waiver and references to the specific standards of practice shall be clearly stated in writing and included in the Department permit. Restrictions on the use of the permit should be imposed as necessary to keep potential safety problems to a minimum. By the terms and conditions of the permit, the permittee may be required to improve, modify, eliminate, or correct the condition giving rise to the waiver when it becomes evident that the reason for the waiver no longer exists. If the waiver is approved and the remainder of the application is in order, meets remaining Code criteria, a permit shall be approved and the subsequent Notice to Proceed may be approved.
- (5) If a waiver is granted to allow direct highway access where the access proposal cannot meet regular access Code standards, or when the property would be without reasonable access absent the waiver, the access permit may contain specific terms and conditions providing for its expiration at such time as the necessity for the waiver no longer exists.
- (6) If the waiver request is denied, the issuing authority shall continue to process the permit application in a standard manner and may issue a permit if it can be approved without a waiver.
- (7) The recommendations and actions of the Department regarding the waiver shall be in writing on form No. 112 with pertinent information attached and shall be included as part of the permit application files. Waiver approval may only be authorized by a licensed professional engineer. This may be the appropriate Department Regional Transportation Director, or her or his designee, or Chief Engineer. The Department may include in its action any special terms and conditions that shall be imposed on the permit if approved.
- (8) If the waiver request was not approved at the Department's Regional level and if the applicant believes their request for waiver was not given the consideration it deserves, or believes the decision was not fair, the applicant may request a decision review by the Department's Access Review Committee.

Editor's Notes

History