

**DEPARTMENT OF REGULATORY AGENCIES**

**State Plumbing Board**

**PLUMBING RULES AND REGULATIONS**

**3 CCR 720-1**

*[Editor's Notes follow the text of the rules at the end of this CCR Document.]*

**1.2 STANDARDS**

**A. Colorado Plumbing Code**

The Board hereby adopts and incorporates by reference, with certain additions, revisions, and deletions, the following chapters, sections, and appendices of the International Plumbing Code ("IPC") and International Residential Code ("IRC").

These Rules, together with the following incorporated provisions, shall be known as the Colorado Plumbing Code. The Colorado Plumbing Code sets forth the minimum standards governing the inspection, installation, alteration, and repair of the plumbing fixtures, appliances, and systems throughout Colorado. The Colorado Plumbing Code does not include any later amendments to or editions of the IPC or IRC provisions listed below.

1. Chapter 1, Sections 101.2, 102, 105, 106.1, 106.3, 106.4, 106.5, 106.5.5, 106.6.1, 107, 108.1, 110.3 Chapters 2-13, 15; and Appendices B, C, D, and E of the IPC, ~~2015~~2018 edition, promulgated by the International Code Council, 1st printing (~~April-2015~~ August 2017).
2. Chapter 1, Section R101, R102; Chapter 2; Chapter 3, Section R305.1 exceptions 1 and 2, Section R306; Chapters 25-32, of the IRC, ~~2015~~2018 edition, promulgated by the International Code Council, 1st printing (~~April-2015~~ August 2017).

**B. Colorado Fuel Gas Code**

The Board hereby adopts and incorporates by reference, with certain additions, revisions, and deletions, the following chapters, sections, and appendices of the International Fuel Gas Code ("IFGC") and the IRC. These Rules, together with the following incorporated provisions, shall be known as the Colorado Fuel Gas Code. The Colorado Fuel Gas Code sets forth the minimum standards governing the inspection, installation, alteration, and repair of fuel gas piping and systems throughout Colorado. The Colorado Fuel Gas Code does not include any later amendments to or editions of the IFGC and IRC provisions listed below.

1. Chapter 1 Section 101, 102, 105, 107, Chapters 2-8 save and except Sections 412 and 413, Appendices A-C of the IFGC, ~~2015~~2018 edition, promulgated by the International Code Council, 1st printing (~~January-2015~~ August 2017).
2. Chapter 1, Section R101, R102; Chapter 2; Chapter 24, Sections G2411-G2422, and G2401.1-Table G2428.3(4) and G2448 of the IRC, ~~2015~~2018 edition, promulgated by the International Code Council, 1st printing (~~April-2015~~ August 2017).

---

C. Public Copies

Copies of the provisions of the IPC, IFGC, and IRC, adopted and incorporated into the Colorado Plumbing Code and the Colorado Fuel Gas Code, are available for public inspection during regular business hours at the Board office at the ~~Division of Professions and Occupations,~~ Department of Regulatory Agencies Welcome Center, 1560 Broadway, ~~Suite 1350~~ Civic Center Plaza, Denver, Colorado, 80202, and at any state publications depository library. For further information regarding how this material can be obtained or examined, contact the Program Director for the Board (“Program Director”) at 1560 Broadway, Suite 1350, Denver, Colorado, 80202, (303) 894-2309. Copies of the IPC, IFGD, and IRC may be obtained from the International Code Council, 500 New Jersey Avenue, NW, 6th Floor, Washington, DC 20001. A list of ICC regional offices is available at <http://www.iccsafe.org/AboutICC/Pages/ContactICC.aspx>.

D. General Interpretations

The following shall apply to the Colorado Plumbing Code and Colorado Fuel Gas Code.

1. **Code Official.** Whenever the Colorado Plumbing Code and the Colorado Fuel Gas Code refer to “the code official,” it shall mean the Board or its designee, if any.
  2. **Reasonable Time.** As used in the Rules, the term “reasonable time” shall mean thirty calendar days.
  3. **Amendments to the Colorado Codes.** Any city, town, county or city and county which adopts more stringent standards than the Colorado Codes shall furnish a copy thereof to the Board.
  4. Abbreviations
    - ANSI – American National Standards Institute
    - ASME – American Society of Mechanical Engineers
    - ASSE – American Society of Sanitary Engineers
    - ASTM – American Society for Testing and Materials
    - C.F.R. – Code of Federal Requirements
    - C.R.S. – Colorado Revised Statutes
    - ICC – International Code Council
    - NFPA – National Fire Protection Association
    - [USC FCCC&HR – University of Southern California, Foundation for Cross-Connection Control and Hydraulic Research](#)
  5. Alternate Materials and Methods Review
    - a. **Criteria.** The Board shall consider requests for approval of alternate materials or methods under the procedures and limitations of Section 105 of the Colorado Plumbing Code and Colorado Fuel Gas Code.
    - b. Procedures
-

- 
- (1) **Petitions for Approval.** Any interested person may petition the Board to amend the Colorado Plumbing or Fuel Gas Code so as to approve the use of an alternate material or method, pursuant to Section 105 of the IPC. Such petition shall conform to the requirements in subsection (2)(b). Incomplete petitions will not be processed.
- (2) **Petition Contents.** Each petition filed under this Rule shall comply with the following requirements:
- (a) **Where to Submit.** Petitions shall be submitted in duplicate to the Program Director.
  - (b) **Petition Document.** Petitions shall begin with a short concise document labeled as the "petition," and which includes the following information:
    - (i) Identification of the petitioner and the petitioner's interest in the alternate materials or methods approval. This identification shall designate one person as the Board's contact for the petition, and list telephone, fax, e-mail, and mailing addresses for that person.
    - (ii) A full description of the types of uses for which the petitioner would like approval. This list should be sufficiently detailed to allow the Board to consider specific types of applications or uses for the alternate material and/or method.
    - (iii) A complete identification of the applicable standards from the Referenced Standards identified in the Colorado Plumbing Code or Colorado Fuel Gas Code that the petitioner proposes to be the acceptance criteria for the alternate material or method.
    - (iv) If the petition is for approval of an alternate material, one sample of the material. The sample will be returned to the petitioner after completion of the review process.
    - (v) Copy of approval language of each code the petitioner cites.
  - (c) **Submission of National Standards.** Each petition shall be accompanied by a set of the applicable standards from the Referenced Standards identified in the Colorado Plumbing Code, Colorado Fuel Gas Code or other standards listed by the petitioner in Rule 1.2(D)(5)(b)(2)(iii). If the listed standard incorporates other standards into its criteria, copies of the incorporated standards shall be submitted as well.
  - (d) **Results of Independent Third Party Compliance Testing.** Each petition shall be supported with complete copies of test reports with protocols issued within the previous eighteen months prior to the date of submission by a laboratory or other testing facility that is recognized as a nationally recognized testing laboratory, pursuant to 29 C.F.R. section 1910.7, or by an ANSI accredited third-party certifier.
-

---

(e) **Compliance with Section 105.** Each petition shall be supported by detailed written discussion as to why the proposed alternate material or method meets the following requirements from Section 105 of the IPC:

- (i) That the proposed design of the proposed alternate material is satisfactory and complies with the intent of the Colorado Plumbing Code or Colorado Fuel Gas Code.
- (ii) That the proposed material is appropriate for the proposed intended use at least the equivalent of that prescribed in the Colorado Plumbing Code or Colorado Fuel Gas Code with respect to quality, strength, effectiveness, durability and safety. This description requires that the petitioner directly compare the quality, strength, effectiveness, durability and safety data on the applicable conventional systems with the tested and documented performance characteristics of the proposed alternate material and/or method.
- (iii) When an alternate installation method is proposed, the petitioner shall describe how the proposed method of installation conforms to the most recently adopted edition of the Colorado Plumbing Code or Colorado Fuel Gas Code.

c. **Reconsideration of Board Action**

Any petitioner whose petition has not been fully granted by the Board may apply for reconsideration of the Board's decision within thirty days of the mailing of the Board's notice of denial, publication of notice of termination, or publication of the Board Rule that partially granted the petition. A request for reconsideration shall be in writing and shall explain why reconsideration is warranted. Action on any request for reconsideration is within the sole discretion of the Board.

Formatted: Font: Bold

Formatted: Indent: Left: 1.5"

6. **Fee Establishment.** Licensing, permit, and reinspection fees shall be established pursuant to section 12-20-105, C.R.S., and shall be categorized appropriately, such as original license, registration, endorsement, renewal, reinstatement fees, permit fees, and reinspection fees.
7. **Information Only Sections.** Installations detailed in the Colorado Plumbing Code that are typically not installed by plumbers (i.e., shower wall composition from Sections ~~417.4.1421.4.1~~, IPC and P2710.1, IRC; Shower floors from Sections ~~417.5421.5~~, IPC and P2709.2, P2709.3, IRC) are not subject to licensing, permitting or inspection but are informational only.
8. Definitions
- a. **Certified Cross-Connection Control Technician** means a person who possesses a valid Backflow Prevention Assembly Tester certification from one of the following approved organizations: American Society of Sanitary Engineering (ASSE), ~~or~~ the American Backflow Prevention Association (ABPA), ~~or~~ other agency recognized by the Board.
9. Clarification of "Domestic appliances" referenced in section 12-155-118(6)(a)(I), C.R.S. and "faucets" as shown in section 12-155-118(6)(a)(II), C.R.S.
-

---

Water heaters used to supply domestic hot water to a residential or commercial potable water system are not equipped with backflow preventers. Therefore, they do not fall under the exemption in section 12-155-118(6)(a)(I), C.R.S.

Shower valves and tub and shower valves referenced in 2018 IPC sections 412.3 to 412.8 and 2018 IRC section P2708.4 shall not be considered "faucets". Therefore, they do not fall under the exemption in section 12-155-118-(6)(a)(II) CRS. Therefore, they do not fall under the exemption in section 12-155-118(6)(a)(I), C.R.S.

10. Clarification of back flow prevention device installation requirements.

A plumbing license is not required for persons engaged in the business of inspecting, testing, and repairing backflow prevention devices. 12-155-118. Exemptions (4) CRS requires persons engaged in the installation and removal of such devices to be a registered and licensed plumbing contractor.

E. Revisions and Exceptions to the Incorporated Codes

1. Revisions and Exceptions to the Colorado Plumbing Code

a. IPC Section 102.8 Referenced codes and standards

Delete in its entirety and replace with:

**[A] 102.8 Referenced codes and standards.** The codes and standards referenced in this code shall be those that are listed in Chapter 15 and such codes and standards adopted or recognized by the Plumbing Board shall be considered as part of the requirements of this code to the prescribed extent of each such reference.

b. IPC Section 202 Definitions

Add new definitions to read:

**Direct Supervision.** Direct supervision means that the supervising licensed master plumber, journeyman plumber, or residential plumber is physically present at the same physical addresses listed on the permits and where the apprentice is working or and no more than five minutes distance from the apprentice.

Commented [YJ1]: Stakeholder edit

bc. IPC Section 202 Definitions

Add new definitions to read:

**Trap drain.** That portion of horizontal piping between the weir of a trap and the point where it intersects with the vent serving that same trap (trap arm).

ed. IPC Section 202 Definitions

~~**Fixture Drain.**~~ Delete the definition and replace with:

**Fixture Drain.** That portion of a plumbing drainage system that connects the trap drain to any other drain pipe receiving the discharge from one or more plumbing fixtures.

e. IPC Section 202 Definitions

Commented [YJ2]: CDPHE addition

---

Delete the definition and replace with:

**Graywater.** Wastewater that, before being treated or combined with other wastewater, is collected from fixtures within residential, commercial, or industrial buildings or institutional facilities for the purpose of being put to beneficial uses. Sources of graywater are limited to discharges from bathroom and laundry room sinks, bathtubs, showers, and laundry machines. Graywater does not include the wastewater from toilets, urinals, kitchen sinks, dishwashers, or non-laundry utility sinks.

f. IPC Section 202 Definitions

Delete the definition and replace with:

**Reclaimed Water.** Domestic wastewater that has received secondary treatment by a domestic wastewater treatment works (centralized system or a localized system) and such additional treatment as to enable the wastewater to meet the standards for approved uses.

Commented [YJ3]: CDPHE addition

g. IPC Section 305.1 Protection against contact.

Delete section in its entirety and replace with:

**IPC Section 305.1** Protection against contact. Piping except for, for cast iron, ductile iron, and galvanized steel shall not be placed in direct contact with steel framing members. Piping shall not be placed in direct contact with concrete or cinder walls and floors, other masonry, and corrosive soil. Where sheathing is used to prevent direct contact, the sheathing shall have a thickness of not less than .025 inch (.64 mm). Where sheathing protects piping that penetrates concrete or masonry walls or floors, the sheathing shall be installed in a manner that allows movement of the piping within the sheathing.

Formatted: Font: Bold

hd. IPC Section 308 Interval of support

308.5 Interval of support

Add new sentence at the end of the section to read:

Hanger support rods shall be sized in accordance with table 308.5.1

ie. Add new Table 308.5.1 Hanger Rod Size

<b>Pipe and Tube Size</b>	<b>Rod Size</b>
½" – 4"	3/8"
5" – 8"	½"
10" – 12"	5/8"

if. IPC Section ~~305.7.1~~308.7.1 Location

Delete in its entirety and replace with:

---

**305.7.1308.7.1 Location.** For pipe sizes greater than four inches (102 mm), restraints shall be provided for drain pipes utilizing mechanical joints at all changes in direction and at all changes in diameter greater than two pipe sizes. Braces, blocks, rodding and other suitable methods as specified by the coupling manufacturer shall be utilized.

**kg.** IPC Section 312.1 Required tests

Delete the words “for piping systems other than plastic” and “After the plumbing fixtures have been set and their traps filled with water, the entire drainage system shall be submitted to final tests. The code official shall require the removal of any cleanouts if necessary to ascertain whether the pressure has reached all parts of the system.”

**lh.** IPC Section 312.3 Drainage and vent air test

Delete the words “Plastic piping shall not be tested using air.”

**mi.** IPC Section 312.4 Drainage and vent final test

Delete in its entirety.

**nj.** IPC Section 312.5 Water supply system test

Delete the words “for piping systems other than plastic.”

**ok.** IPC Section 312.9 Shower liner test

Delete in its entirety.

**pl.** IPC Section 312.10.1 Inspections

Delete the verbiage entirely and replace it with:

**312.10.2 Testing.** Reduced pressure principle, double check, pressure vacuum breaker, reduced pressure detector fire protection, double check detector fire protection, and spill-resistant vacuum breaker backflow preventer assemblies and hose connection backflow preventers shall be tested at the time of installation, immediately after repairs or relocation and at least annually by a certified cross connection control technician, in accordance with the applicable testing procedures associated with each specific certifying agency. When applicable t. The testing procedure shall be performed for the identified backflow prevention assembly in its entirety in accordance with one of the following applicable standards: ASSE 5013, ASSE 5015, ASSE 5020, ASSE 5047, ASSE 5048, ASSE 5052, ASSE 5056, CSA B64.10, ~~or~~ CSA B64.10.1 or the testing procedures provided in the 10th Edition Manual of Cross-Connection Control ~~current~~ from the University of Southern California's Foundation for Cross-Connection Control and Hydraulic Research testing procedures.

The testing procedures from the 10th Edition Manual of Cross-Connection Control from the University of Southern California's Foundation for Cross-Connection Control and Hydraulic Research is incorporated by reference, and may be examined at the Colorado Plumbing Board's office at 1560 Broadway, Suite 1350, Denver, Colorado 80202, during normal business hours, Monday through Friday, except days designated as state holidays. Certified copies of the 10th Edition Manual of Cross-Connection Control shall be provided at cost, upon request. The Board or the Board's staff will provide information regarding how the

**Commented [YJ4]:** CDPHE addition

**Commented [YJ5]:** Incomplete sentence

**Commented [MD6]:** This needs to be spelled out and properly incorporated by reference per statute.

**Formatted:** upar4

---

10th Edition Manual of Cross-Connection Control may be examined for free at the state public depository library. The 10th Edition Manual of Cross-Connection Control is also available from the agency, organization or association originally issuing the code, standard, guideline, or rule at: USC Foundation Office, Research Annex 219, Los Angeles, CA 90089-7700 or (<https://fccchr.usc.edu/>). This rule does not include any later amendments or editions of the code, standard, guideline, or rule.

**gm.** IPC Section 403.1 Minimum number of fixtures

Add a new sentence to the end of the section to read as follows:

Lavatory to water closet or urinal ratios in accordance with Table 403.1 shall be maintained in all restrooms.

**rn.** IPC Section 405.3.2 Public Lavatories

Add a new exception reading:

**Exception:** Lavatories located outside a toilet room located within a classroom serving students from that classroom only. These toilet rooms and lavatories shall not count toward the total fixture count required by Table 403.1.

**s.** ~~IPC~~ Section 410.4 Substitution.

Change first sentence to read:

Where restaurants (or spaces classified as an A2 occupancy) provide drinking water in a container free of charge, drinking fountains shall not be required in (these restaurants and A2 occupancies).

**te.** IPC Section ~~417.7421.7~~ Shower head location

Add new section to read:

**417.7421.7 Shower head location.** Showerheads shall be located on the sidewall of shower compartments or be arranged so the shower head does not discharge directly at the entrance to the compartment and the bather can adjust the valve prior to stepping into the shower spray.

**Exception:** Showers of the roll in type installed in accordance with 2009 ANSI A117.1.

**up.** IPC Section ~~417.8421.8~~ Shower valve location

Add new section to read:

**417.8421.8 Shower valve location.** A shower or tub/shower control valve shall be installed only where the spout and/or shower head discharges into an approved tub or shower compartment.

**Exception:** Emergency Showers.

**vq.** IPC Section ~~420.3425.3~~ Water closet seats

Add new exception to read:

Commented [YJ7]: PPRBD note

Commented [YJ8]: PPRBD note.

Formatted: Font color: Auto

Formatted: Font color: Auto

Formatted: Indent: First line: 0"



---

**Exception:** Water closets installed in public restrooms for the purpose of complying with accessible fixtures as required by Section 404 fitted with the "AXS-Wingman Universal Design Water Closet Seat" having a closed front are allowed.

wf. IPC Section 504.6.1 Collection of Relief Valve Discharge

Add new section 504.6.1 to read:

**504.6.1. Collection of Relief Valve Discharge.** A means shall be provided to capture the discharge from a relief valve and convey it to the sanitary drainage system or exterior of the structure either by gravity or a pumped discharge.

**Exceptions:**

~~(1).~~ Replacements for existing water heaters.

~~(2).~~ Where a water sensing device wired to a normally closed solenoid valve installed in the water supply piping to the heaterservice-piping is placed within the water heater drain pan.

xs. IPC Section 504.6.1.1 Pumped discharge of relief valve collection

Add new Section 504.6.1 to read as follows:

**504.6.1.1 Pumped discharge of relief valve collection.** Pumps used to discharge the clear water collection of relief valves shall have an operating temperature equal to or exceeding that of the relief valve discharge temperature and shall have a gpm rating equal to or greater than the discharge of the relief valve.

y. IPC Section 504.7 Required pan.

Add new exception to read:

Replacements for water heaters that did not have a pan previously installed to code in effect at the time of the original installation.

z. IPC Section 504.7 Required pan.

Add new sentence at end of the section to read:

Unless the pan is constructed of material having a flame spread index of 25 or less and a smoke-developed index of 450 or less when tested in accordance with ASTM E84 or UL 723.

aat. IPC Section ~~605.16.2~~605.15.2 Solvent cementing

Delete the exception in its entirety.

bbu. IPC Section ~~608.8.1~~608.9.1 Signage required

Delete the section in its entirety and replace with:

(1A-) Plumbing fixtures flushed with nonpotable water shall be identified with signage that reads as follows:

Formatted: Font: Bold

"Nonpotable water is used to flush this fixture. CAUTION:  
NONPOTABLE WATER – DO NOT DRINK."

In addition to the required wordage, the pictograph shown in figure  
608.8.1 shall appear on the required signage.

~~(2)B.~~ A permanent warning sign must also be visible at all fixtures from which  
graywater is collected. The sign must state that:

"WATER FROM THIS FIXTURE IS REUSED. CHEMICALS, EXCRETA,  
PETROLEUM OILS AND HAZARDOUS MATERIALS MUST NOT BE  
DISPOSED DOWN THIS DRAIN."

~~(3)C.~~ For both types of fixtures indicated in subsections 1.2(E)(1)(b)(1)(i) and  
(ii), the words shall be legibly and indelibly printed on a tag or sign  
constructed of corrosion-resistant waterproof material or shall be  
indelibly printed on the fixture. The letters of the words shall be not less  
than 0.5 inch (12.7 mm) in height and in colors in contrast to the  
background on which they are applied.

ccv. IPC Section ~~608.8-2608.9.2~~ Distribution pipe labeling and marking

Delete the section verbiage and replace with:

Nonpotable distribution piping shall be purple in color or the piping shall be  
installed with a purple identification tape or wrap the entire length of the piping  
and shall be embossed, or integrally stamped or marked, with the words:  
"CAUTION: NONPOTABLE WATER – DO NOT DRINK".

dd. IPC Section 608-17 Connections to the Potable Water Systems

Add new subsection 608.17.2.1 to read:

Section 608.17.2.1 essentially nontoxic fluid conditioning chemical.

When the conditioning chemical introduced is an essentially nontoxic transfer  
fluid the potable supplier to the boiler shall, at a minimum, be equipped with a  
backflow preventer with an intermediate atmospheric vent complying with ASSE  
1012 or CSA B64.3.

Commented [YJ9]: CDPHE addition

Formatted: Normal, Indent: Left: 1.5", Don't adjust space  
between Latin and Asian text, Don't adjust space between  
Asian text and numbers

wee. IPC Section 608 Protection of potable water system

Add new subsection ~~608.16-14608.17.11~~ to read:

**Section ~~608.16-14608.17.11~~ Connection to graywater system or reclaimed water  
system**

The potable water system connection to a graywater system must be protected  
against backflow by an air gap or reduced pressure principle backflow prevention  
assembly.

Formatted: Font: Bold

Formatted: Indent: Left: 1.5", First line: 0"

Commented [YJ10]: CDPHE addition

ffx. IPC Section ~~705.11-2705.10.2~~ Solvent cementing

Delete the exception in its entirety.

gg. IPC Section 706.3. Installation of fittings

~~Add sentence to end of IPC Section 706.3:~~

~~fixture crosses will not be required to meet the exception of IPC Section 706.3~~

~~hh. IPC Section 706.3.~~

~~Add sentence to end of IPC Section 706.3:~~

~~fixture crosses will not be required to meet the exception of IPC Section 706.3~~

~~iiy. IPC Table 706.3 Fittings for change of direction~~

~~Delete footnotes a and b from the table.~~

~~ji. IPC Section 708.1.3 Building drain and building sewer junction.~~

~~Add new sentence at the end of the section to read:~~

~~When the cleanout is installed at the junction of the building drain and building sewer, it shall be an approved two way fitting with a single riser not to exceed 4 feet in depth or a two riser cleanout using back to back combination fittings or equal of schedule 40 material.~~

~~kk. IPC Section 714.1 Sewage backflow.~~

~~Delete section in its entirety and replace with:~~

~~Backwater valves shall be installed where waste receptors are located in a crawl space for the purpose of receiving condensate discharge from equipment located in that crawl space. Refer to new exception for 802.4~~

~~z. IPC Section 802.2 Installation~~

~~Delete the last sentence.~~

~~kk!aa. IPC Section 802.1.8 Domestic dishwashing machines~~

~~Add a new section to read:~~

~~Domestic dishwashing machines may be connected to a separately trapped stand pipe provided with an air break (with drain hose secured to the underside of the counter top) or air gap as shown in the illustration below. Refer to 2018 IPC 409.4 for additional waste connections. IPC Section 802.1.6 Domestic dishwashing machines~~

~~Add an exception to read:~~

~~**Exception:** Domestic dishwashing machines may be connected to a separately trapped stand pipe provided with an air break as shown in the illustration below.~~

Formatted: par3

Commented [YJ11]: PPRBD note

Formatted: Font color: Auto

Formatted: Font color: Auto

Formatted: Indent: First line: 0"

Formatted: Indent: Left: 1.5", First line: 0"

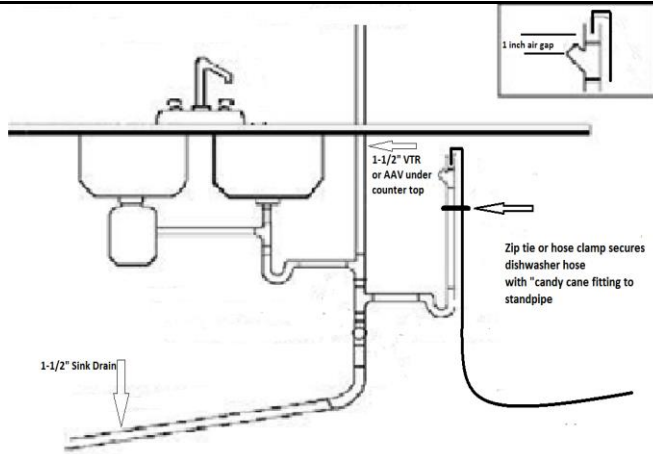

llmm. IPC Section 802.3 Installation

Delete the last sentence

mman. IPC Section 802.4 Waste receptors.

Add new exception to read:

**Exception:** Where equipment is installed in a crawl space, a waste receptor shall be allowed, with an approved backwater valve installed, shall be permitted.

nneebb. IPC Section 903.1 Roof extensions

Insert 6 inches into the section so that it reads: "All open vent pipes that extend through a roof shall be terminated at least 6 inches above the roof, except that where a roof is to be used for any purpose other than weather protection, the vent shall be extended at least seven feet (2134 mm) above the roof."

oopppe. IPC Section 903.2 Frost Closure

Delete in its entirety.

ppqede. IPC Section 912.1 Horizontal wet vent permitted

Add a new exception to read:

**Exception:** Fixtures other than those considered to be bathroom group fixtures, of equivalent drainage fixture units, may be included in the wet vented section provided the total number of drainage fixture units does not exceed the total number included in two bathroom groups and the fixtures not considered bathroom fixtures are valued at one drainage fixture unit or less.

qqftee. IPC Section 1002.1 Fixture traps

Add new exception 5 to read:

Formatted: Indent: First line: 0"

Commented [YJ12]: PPRBD note

Formatted: Font: Not Bold, Font color: Auto

Formatted: Font color: Auto

Formatted: Font: Not Bold, Font color: Auto

Formatted: Font: Not Bold, Font color: Auto

Formatted: Font color: Auto

Formatted: Font: Not Bold, Font color: Auto

Formatted: Font color: Auto

Formatted: Font color: Auto

Formatted: Font color: Auto

Formatted: Font color: Auto

**Exception:** 5. Trench and floor drains connected to a sand oil interceptor need not be individually trapped provided the drain piping from the trench or floor drains is turned down after entering the interceptor so the discharge point is a minimum of 4 inches below the standing water level of the interceptor.

rrsff. IPC Section 1003.1 Where required

Add the following Exception:

**Exception:** Where special regulations exist by the local waste water and/or sanitation district into which the grease trap or interceptor effluent is transported and/or treated. These regulations may supersede this requirement.

ssff. IPC.1003.2.3 Food waste disposers restriction.

Add exception to read:

When using a gravity interceptor equal to or greater than 500 gallon capacity.

tteggg. IPC Section 1101.3 Prohibited drainage

Add a new sentence to the end of the section reading:

Storm water from roof drains shall not discharge over public walkways except when an approved grated trough or trench drain sized to accept the calculated discharge is installed in the walkway. The discharge shall be diverted vertically from a height not greater than 12 inches to the grate.

**Exception:** Secondary drains.

uuuff. IPC Section 1301.2.2 Filtration Required Exception

Modify section 1301.2.2 Exemption reading:

Nonpotable water utilized for water closet and urinal flushing application shall be filtered by a 100-micron or fine filter.

Exception: Reclaimed water sources shall not be required to comply with these requirements. Graywater treatment systems installed in accordance with Section 1302.6.1 do not need to meet additional filtration requirements.

vvssh. IPC Section 1301 General

Add new section 1301.3.1 reading:

**1301.3.1.** Distribution pipe labeling and marking

Nonpotable distribution piping shall comply with Section 608.8.2 as amended in Rule 1.2(E)(1)(v).

wwtt. IPC Section 1301.3.2 Signage required graywater treatment works.

Add section new section 1301.3.2 reading:

For each room that contains graywater treatment works components, a sign that says "CAUTION GRAYWATER TREATMENT WORKS, DO NOT DRINK, DO

Formatted: Space After: 12 pt

Commented [YJ13]: CDPHE addition

Formatted: Space Before: 12 pt

Formatted: Font: Bold

Formatted: Indent: Left: 1.5", First line: 0", Tab stops: 1.44", Left

Formatted: Font: Bold

Formatted: Space After: 12 pt

Commented [YJ14]: CDPHE addition

Commented [YJ15]: John – CDPHE number this 1301.3.1 but you already have a 1301.3.1 – can you renumber this properly? Thanks! –jjy

**NOT CONNECT TO THE POTABLE DRINKING WATER SYSTEM. NOTICE:  
CONTACT BUILDING MANAGEMENT BEFORE PERFORMING**

**ANY WORK ON THIS WATER SYSTEM" must be posted on any door providing  
entrance to the room.**

**IPC Section 1301 General**

Add new figure 1301.4

**1301.4 Typical Graywater Collection System**

(This figure is typical only, not a schematic)

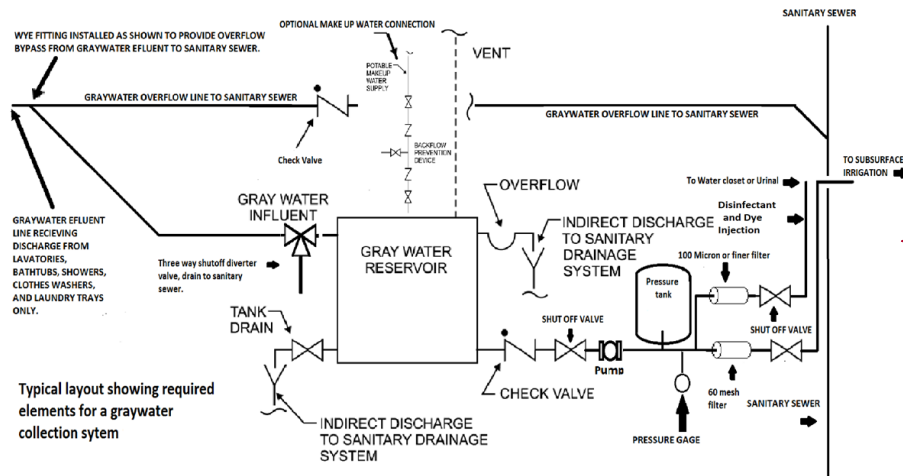

Typical layout showing required elements for a graywater collection system

**IPC Section 1301 General**

Add new figure 1301.5

**1301.5 Typical graywater system for toilet and urinal flushing**

**Formatted: Indent: First line: 0"**

**Formatted: Font: Bold**

**Formatted: Indent: Left: 0.25"**

**Commented [YJ16]: CDPHE addition**

**Formatted: Font: Bold**

**Formatted: Indent: First line: 0"**

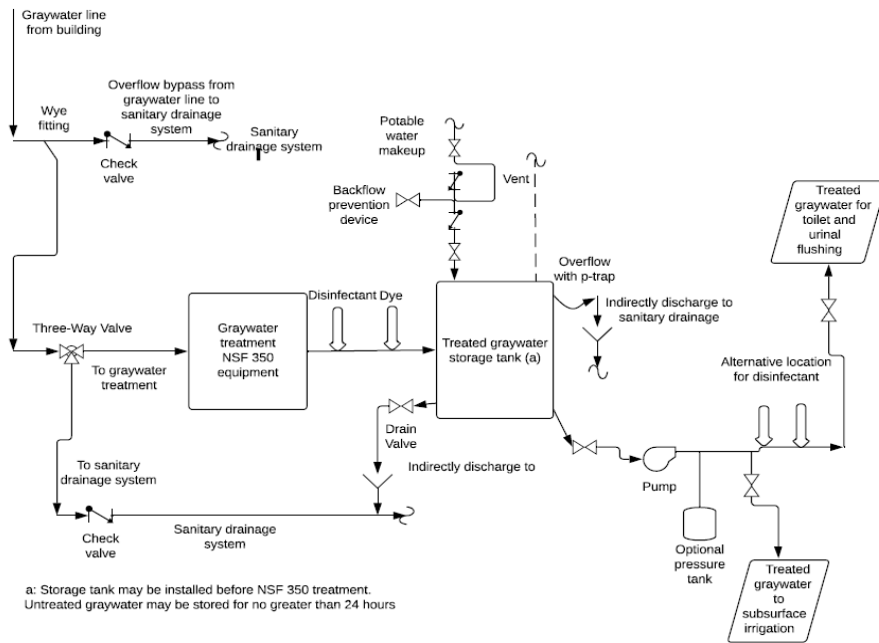

Formatted: Indent: Left: 0", First line: 0", Tab stops: Not at 1.5"

zzwww IPC Section 1301 General

Commented [YJ17]: CDPHE addition

Add new figure 1301.6

1301.6 Typical graywater system for disburSED subsurface irrigation system

Formatted: Font: Bold

Formatted: Indent: First line: 0"

**Formatted:** Indent: Left: 0.25", First line: 0", Tab stops: Not at 0.5" + 1" + 1.5"

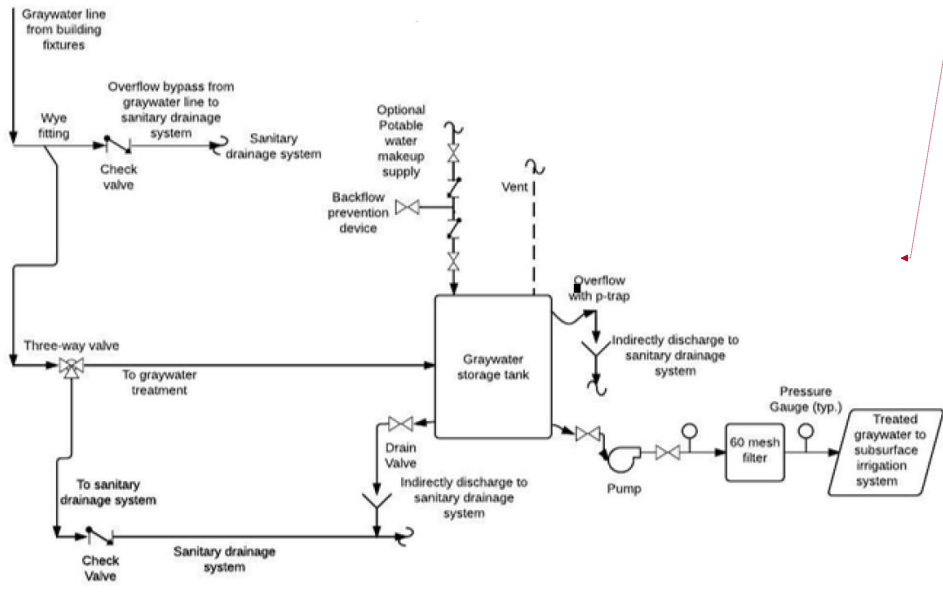

aaa.xx. IPC Section 1301 General

Add new figure 1301.7

1301.7 Typical graywater system for mulch basin subsurface irrigation

**Formatted:** Font: Arial, 10 pt, Bold



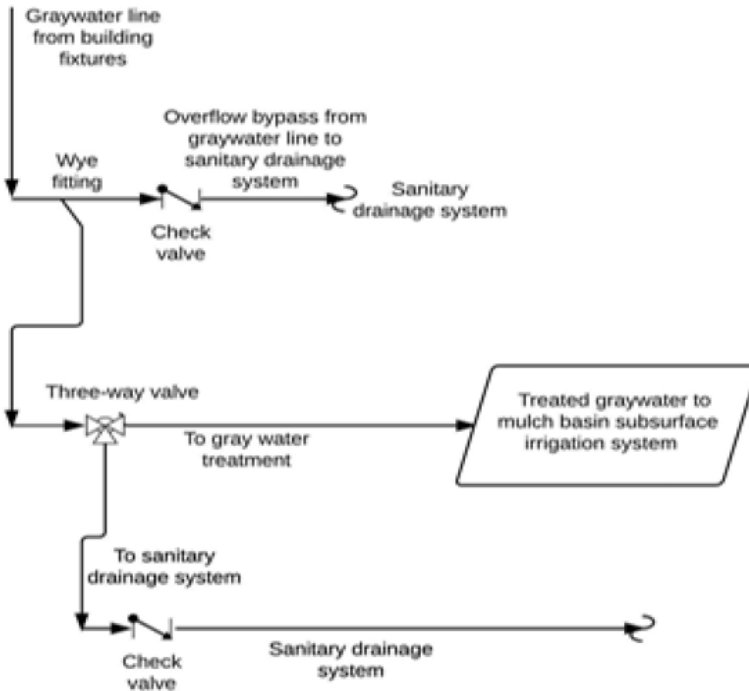

~~bbwy~~ IPC Section 1301.9.2 Materials Exception Add section

Commented [YJ18]: CDPHE addition

1301.9.2 Exemption reading:

Exemption. Tanks are not required if the graywater use is comprised of only subsurface irrigation and flows into a mulch basin system, where the mulch basin volume is three times the anticipated average daily flow.

Formatted: Indent: First line: 0"

~~ccczzj~~ IPC Section ~~1301.9.6~~1301.9.5 Overflow

Delete the section verbiage and replace with:

The storage tank shall be equipped with an overflow pipe having a diameter not less than that shown in Table 606.5.4. The overflow pipe shall be protected from insects or vermin. The overflow drain shall not be equipped with a shutoff valve and shall discharge into the sanitary sewer either directly, or indirectly with a trap in the drain line to keep odors from escaping the tank. A cleanout shall be provided on each overflow pipe in accordance with Section 708.

~~Dddaakk~~—IPC Section ~~1301.9.9~~1301.9.8 Draining of tanks

---

Delete the text "shall discharge as required for overflow pipes and". Replace it with: shall discharge into the sanitary sewer either directly, or indirectly with a trap in the drain line to keep odors from escaping the tank

eeebbb!. IPC Section 1301.11 Trenching Requirements

Delete in its entirety.

ffecemm. IPC Section 1301.12 Outdoor Outlet Access

Delete in its entirety.

ggdddn. IPC Section 1302.1 General

Add a sentence to the end of the section saying:

All plumbing systems utilizing nonpotable water reuse systems shall have a ~~double check valve~~ reduced pressure backflow preventer device installed at the water service entrance immediately downstream of the building water service shut off valve.

hhheeee. IPC Section ~~1302.5.1~~1302.5 Filtration

Add a new sentence to the end of the section saying:

**1302.5.1302.5 Filtration:** Graywater used for dispersed subsurface irrigation system requires a cartridge filter. The cartridge filter must be a minimum of sixty mesh located between the storage tank and the irrigation system.

**Exemption.** Filtration is not required for mulch basin subsurface irrigation systems.

**Commented [YJ19]:** CDPHE addition

**Formatted:** Indent: First line: 0"

iiiffpp. IPC Section 1302.6.1 Graywater used for fixture flushing

Add a new sentence to the end of the section reading:

Graywater used for toilet and urinal flushing shall be dyed with blue or green food grade vegetable dye and be visibly distinct from potable water.

jjggqqq. IPC Section ~~1302.7.4~~1302.7.3 Overflow

Add a new Section ~~1302.7.4~~1302.7.3 that reads:

**1302.7.41302.7.3 Overflow.** Storage tank for on-site nonpotable systems must include an overflow line without a shut off valve. The overflow line shall be connected to the sanitary sewer ~~either directly or~~ indirectly. The overflow line must be the same or larger diameter line than the tank influent line. The overflow line connected indirectly must be trapped to prevent the escape of gas vapors from the tank

kkhhrrf. IPC Section ~~1302.7.5~~1302.7.4 Venting

Add a new Section ~~1302.7.5~~1302.7.4 that reads:

---

---

**1302.7.5** **1302.7.4 Venting.** Storage tank for on-site nonpotable systems must be vented. Indoor tanks must be vented to the atmosphere outside the building or connected to the plumbing vent system.

**1302.7.6** **1302.7.5 Tank Drains**

Add a new Section **1302.7.6** **1302.7.5** that reads:

**1302.7.6** **1302.7.5 Tank Drains.** Storage tank for on-site nonpotable systems must include a valved drain. The drain shall be indirectly connected to the sanitary sewer. The tank drainline must be the same or larger diameter line than the tank influent line.

**1302.8.1** **Bypass Valve**

Change the section heading and section verbiage to read:

**Section 1302.8.1 System Bypass**

Formatted: Font: Bold

Delete the section verbiage and replace with:

One three-way diverter valve listed and labeled to NSF 50 or other approved device shall be installed on collection piping upstream of any graywater treatment equipment, as applicable, to divert untreated on-site reuse sources to the sanitary sewer to allow servicing and inspection of the system. Bypass valves shall be installed downstream of fixture traps and vent connections. Bypass valves shall be marked to indicate the direction of flow, connection ~~and storage tank or drainfield connection~~ **graywater treatment works, storage tank and graywater subsurface irrigation systems**. Bypass valves shall be installed in accessible locations. Two shutoff valves shall not be installed to serve as a bypass valve. In addition to the bypass valve a series of drainage fittings shall be installed in the collection piping upstream of the bypass valve in a configuration that will allow the graywater from the plumbing fixtures to automatically flow directly into the sanitary sewer system in the event the filter or other parts of the collection system become clogged to the point of not allowing the effluent free flow through the system. The overflow line connected to the sanitary sewer shall be equipped with a backwater valve.

Commented [YJ20]: CDPHE addition

**1303** **Nonpotable rainwater collection and distribution systems**

Delete in its entirety.

**14** **Subsurface landscape irrigation systems**

Delete in its entirety.

2. Revisions and Exceptions to the International Residential Code Part VII incorporated as the Colorado Plumbing Code

a. IRC Section R202 Definitions

Add new definition to read as follows:

**Multipurpose Residential Fire Sprinkler System.** A Multipurpose Residential Fire Sprinkler System includes the domestic water distribution piping and the fire

---

---

sprinkler piping which shall be a part of and connect to the cold water distribution piping at any point.

**b.** IRC Section R202 Definitions

Add new definitions to read:

**Direct Supervision.** Direct supervision means that the supervising licensed master plumber, journeyman plumber, or residential plumber is physically present at the same physical addresses listed on the permits and where the apprentice is working or, and no more than five minutes distance from the apprentice.

Formatted: Indent: First line: 0"

Commented [YJ21]: Stakeholder edit

**bc.** IRC Section R202 Definitions

Add new definition to read as follows:

**Trap drain.** That portion of horizontal piping between the weir of a trap and the point where it intersects with its vent.

Formatted: Indent: Left: 1.5"

**ed.** IRC Section R202 Definitions

~~**Fixture drain.**~~ Delete the definition and replace with:

**Fixture drain.** That portion of a plumbing drainage system that connects the trap drain to any other drain pipe receiving the discharge from one or more plumbing fixtures.

**de.** IRC Section R202 Definitions

Add new definition to read as follows:

**Manufactured Housing Hookup-Sewer.** That portion of drainage piping and fittings connecting a single point of drainage pipe discharge from the factory installed plumbing of a manufactured home to the sanitary sewer riser under the set home. (More than a single connection to the home drainage piping shall be considered "plumbing" as defined in section 12-155-103, C.R.S., and subject to all provisions of Article 155 of Title 12).

**ef.** IRC Section R202 Definitions

Add new definition to read as follows:

**Manufactured Housing Hookup-Water.** That portion of piping and fittings connecting a single point of water supply from the factory installed water supply pipe of a manufactured home to the potable water riser under the set home.

**g.** IRC Section 202 Definitions

Delete the definition and replace with:

**Reclaimed Water.** Domestic wastewater that has received secondary treatment by a domestic wastewater treatment works (centralized system or a localized

Commented [YJ22]: CDPHE addition

Formatted: Font: Not Bold

Formatted: Indent: First line: 0"

---

---

system) and such additional treatment as to enable the wastewater to meet the standards for approved uses.

hf. IRC Section P2503.5.1 Rough Plumbing

Delete the words “for piping systems other than plastic”.

ig. IRC Section P2503.6 Shower liner test

Delete in its entirety.

hj. IRC Section P2503.7 Water supply system testing

Delete the words “for piping systems other than plastic”

k. ~~IRC Section P2503.5.2 Finished plumbing.~~

Formatted: Font color: Auto

~~Delete 2, 2.1, and 2.2~~

Formatted: Font color: Auto

li. ~~IRC Section P2503.8.2 Testing~~

~~Delete in its entirety.~~

mj. IRC Section P2601.2 Connection to drainage system

Delete the Exception in its entirety.

nm. IRC Section P2605.2 Thermal expansion tanks.

Add new section P2605.2 to read:

P2605.2 Thermal expansion tanks. A thermal expansion tank shall be supported in accordance with the manufacturer's instructions. Thermal expansion tanks shall not be supported by the piping that connects to such tanks.

ok. IRC Section P2603.3 Protection against corrosion.

Delete section in its entirety and replace with:

IRC P2603.3 Protection against corrosion. Piping except for, for cast iron, ductile iron, and galvanized steel shall not be placed in direct contact with steel framing members. Piping shall not be placed in direct contact with concrete or cinder walls and floors, other masonry, and corrosive soil. Where sheathing is used to prevent direct contact, the sheathing shall have a thickness of not less than .025 inch (.64 mm). Where sheathing protects piping that penetrates concrete or masonry walls or floors, the sheathing shall be installed in a manner that allows movement of the piping within the sheathing.~~IRC Section 2603.3 Protection against corrosion~~

~~Delete all instances of the word “metallic” from the section.~~

pl. IRC Section P2705.1 General

Add new exception to read:

---

**Exception:** Lavatory clearance from its center to any sidewall or partition may be reduced to a minimum of twelve inches.

gp. [IRC P2706.1 General \(waste receptors\)](#)

Add new exception to read:

Exception: Where equipment is installed in a crawl space, a waste receptor shall be allowed with an approved backwater valve installed.

Exception: Where equipment is installed in a crawl space, a waste receptor with an approved backwater valve shall be permitted.

gfm. IRC Section P2708.5 Shower head location

Add new section P2708.5 to read:

**P2708.5 Shower head location.** Shower heads shall be so located on the sidewall of shower compartments or be arranged so the shower head does not discharge directly at the entrance to the compartment and the bather can adjust the valve prior to stepping into the shower spray.

fpa. IRC Section ~~P2717.4~~[P2717.3](#) Dishwasher drain

Add new section to read:

**IRC Section ~~P2717.4~~[P2717.3](#) Dishwasher drain.** Dishwashers may drain into a standpipe complying with Section P2706.2 as shown in the following illustration. The standpipe shall be provided with an air break -(with drain hose secured to the underside of the counter top) or air gap as shown in the illustration below.

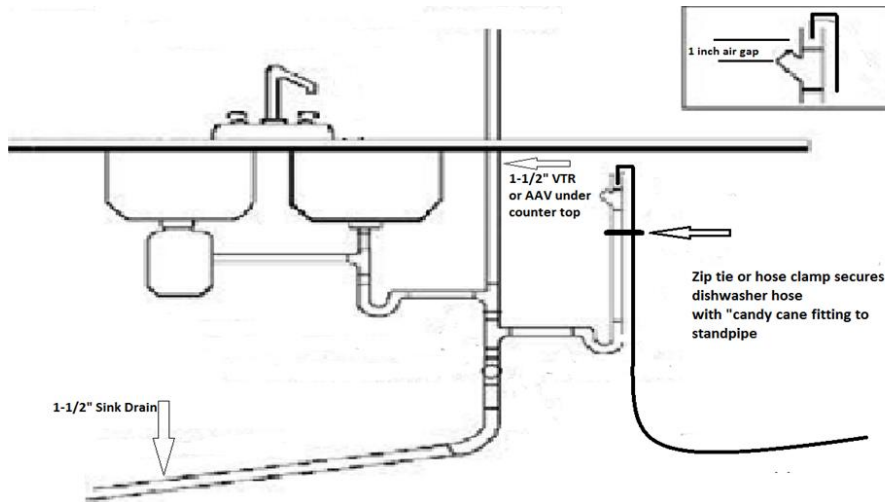

ts. [IRC Section P2801.6 Required pan.](#)

**Commented [YJ23]:** PPRBD note

**Formatted:** Font: Not Bold, Font color: Auto

**Formatted:** Font color: Auto

**Formatted:** Font color: Auto

**Formatted:** Font: Not Bold, Font color: Auto

**Formatted:** Font color: Auto

**Formatted:** Font color: Auto

---

Add new exception to read:

**Exception:** Replacements for water heaters that did not have a pan previously installed due to code in force at the time of installation.

Formatted: Font: Bold

Formatted: Font color: Auto

ute. IRC Section P2803.6.2 Collection of Relief Valve Discharge

Add new section P2803.6.2 to read:

**P2803.6.2 Collection of Relief Valve Discharge.** A means shall be provided to capture the discharge from a relief valve and convey it to the sanitary drainage system or exterior of the structure either by gravity or a pumped discharge.

**Exceptions:**

Formatted: Font: Bold

- (1) Replacements for existing water heaters.
- (2) Where a water sensing device wired to a normally closed solenoid valve installed in the water supply piping to the heater, is placed within the water heater drain pan.

uvp. IRC Section P2803.6.2.1 Pumped discharge of relief valve collection

Add new Section P2803.6.2.1 to read:

**P2803.6.2.1 Pumped discharge of relief valve collection.** Pumps used to discharge the clear water collection of relief valves shall have an operating temperature equal to or exceeding that of the relief valve discharge temperature and shall have a gpm rating equal to or greater than the discharge of the relief valve.

wvq. IRC Section P2901.1 Potable water required

Delete the last sentence of the section.

xwf. IRC Section P2901.1.2.1 Signage required

Delete the section in its entirety and replace with:

Plumbing fixtures flushed with nonpotable water shall be identified with signage that reads as follows:

—————“Nonpotable water is used to flush this fixture. CAUTION:  
NONPOTABLE WATER – DO NOT DRINK.”

Formatted: Indent: Left: 1.5", First line: 0"

In addition to the required wordage, the pictograph shown in figure P2901.2.1 shall appear on the required signage.

ys. IRC New Section P2901.1.2.4

Add new Section P2901.1.2.4 to read:

Graywater used for toilet and urinal flushing shall be dyed with blue or green food grade vegetable dye and be visibly distinct from potable water.

zvt. IRC Section P2901.2.2 Distribution pipe labeling and marking

---

---

Delete the section verbiage and replace with:

Nonpotable distribution piping shall be purple in color or the piping shall be installed with a purple identification tape or wrap the entire length of the piping and shall be embossed, or integrally stamped or marked, with the words: "CAUTION: NONPOTABLE WATER – DO NOT DRINK".

zaa. IRC Section P2902.5 Protection of potable water connections

Commented [YJ24]: CDPHE addition

Add new subsection P2902.5.1.1 to read:

Section P2902.5.1.1 Essentially nontoxic fluid conditioning chemical.

When the conditioning chemical introduced is an essentially nontoxic transfer fluid the potable supplier to the boiler shall, at a minimum, be equipped with a backflow preventer with an intermediate atmospheric vent complying with ASSE 1012 or CSA B64.3.

Formatted: Indent: First line: 0"

bbaau. IRC New Section P2902.5.6 Protection of potable water system

Add new subsection P2902.5.6 to read:

Section P2902.5.6 Connection to graywater system or reclaimed water system

Commented [YJ25]: CDPHE addition

The potable water system connection to a graywater system or reclaimed water system must be protected against backflow by an air gap or reduced pressure principle backflow prevention assembly.

Commented [YJ26]: CDPHE addition

cabb. IRC Section P2903.9.1 Service valve.

Delete the words "with provision for drainage such as a bleed orifice or installation of a separate drain valve"

ddeev. IRC Section P2904 General

Delete in its entirety and replace with:

**P2904.1 General.** Where installed, residential fire sprinkler systems, or portions thereof, shall be in accordance with NFPA 13D or Section P2904, which shall be considered equivalent to NFPA 13D. Section P2904 shall apply to multipurpose wet-pipe sprinkler systems that do not include the use of antifreeze. A multipurpose fire sprinkler system shall supply domestic water to both fire sprinklers and plumbing fixtures. A backflow preventer shall not be required to separate the sprinkler system from the water distribution system.

ddeew. IRC Section P2910 Graywater Recycling Systems

Add new Figure P2910.4 Typical Graywater Collection system.

(This figure is typical only, not a schematic)

---



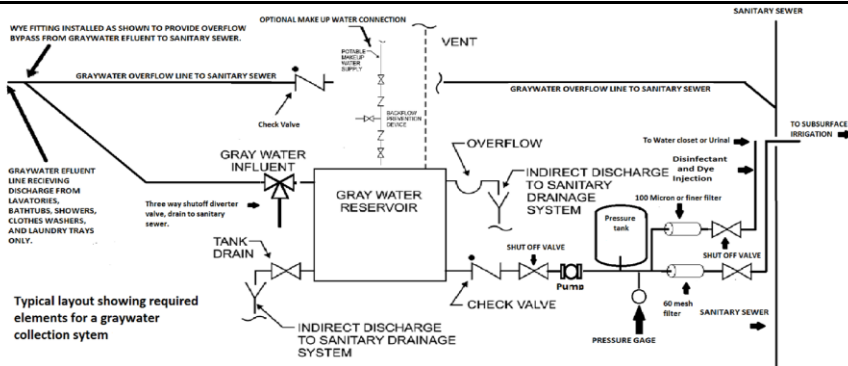

Typical layout showing required elements for a graywater collection system

[ffex.](#) IPC Section [2940.02910.1](#) Scope

Add a sentence to the end of the section saying:

All plumbing systems utilizing nonpotable water reuse systems shall have a ~~double check valve~~ reduced pressure backflow preventer device installed at the water service entrance immediately downstream of the building water service shut off valve.

Formatted: Space After: 12 pt

[gqff.](#) IRC Section [P2910.2.2](#) Filtration Required Exception

Modify section Exemption to read:

**P2910.2.2 Filtration Required. Nonpotable water utilized for water closet and urinal flushing application shall be filtered by a 100-micron or fine filter.**

Formatted: Font: Bold

Formatted: Right: 0.54", Space Before: 0 pt

**Exception: Reclaimed water sources shall not be required to comply with these requirements. Graywater treatment systems installed in accordance with Section P2911.6.1 do not need to meet additional filtration requirements.**

Formatted: Font: Bold

[hhgf.](#) IRC Section [P2910](#) Graywater recycling systems

Commented [YJ28]: CDPHE addition

Add new figure Section 2910.5

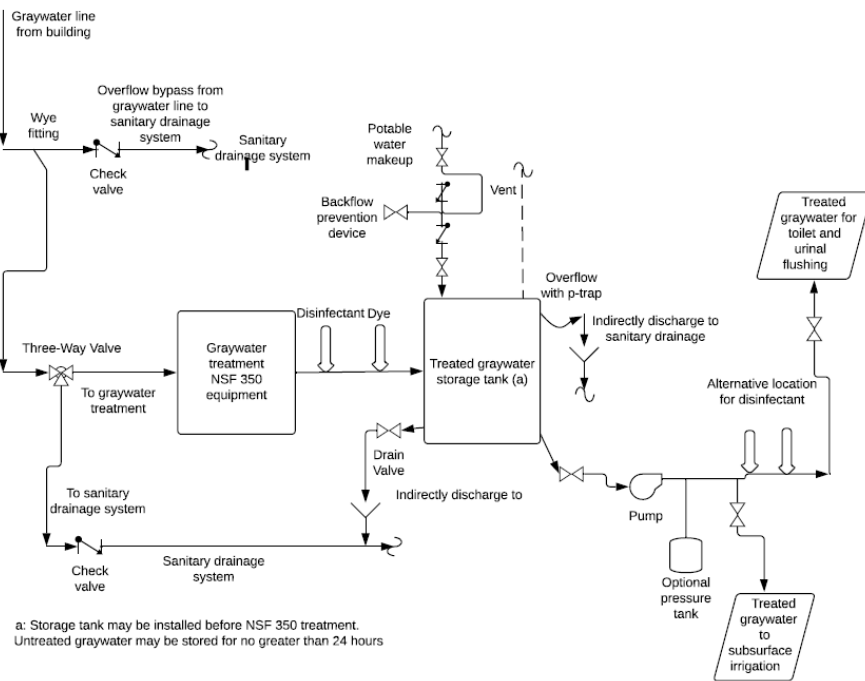

Formatted: Indent: Left: 0.19", First line: 0", Tab stops: Not at 0.5" + 1" + 1.5"

IRC Section P2910 Graywater recycling systems

Commented [YJ29]: CDPHE addition

Add New Figure Section 2910.6

2910.6 Typical graywater system for disbursement to subsurface irrigation system

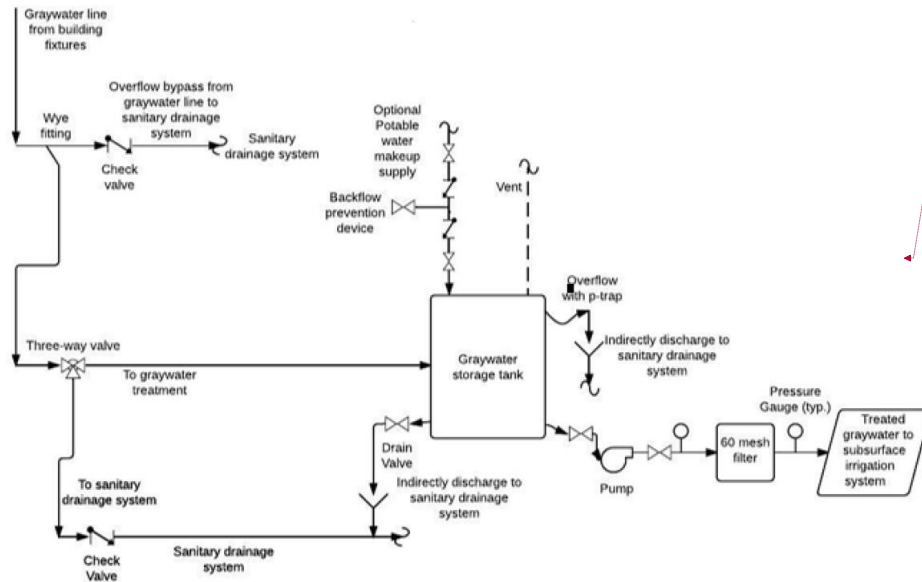

Formatted: Indent: Left: 0.25", First line: 0", Tab stops: Not at 0.5" + 1" + 1.5"

iii. [IRC Section P2910 General](#)

[Add new figure Section 2910.7](#)

[2910.7 Typical graywater system for mulch basin subsurface irrigation](#)

Formatted: Table Paragraph, Indent: Left: 1.5", Right: 0.3", Line spacing: Multiple 2.01 li

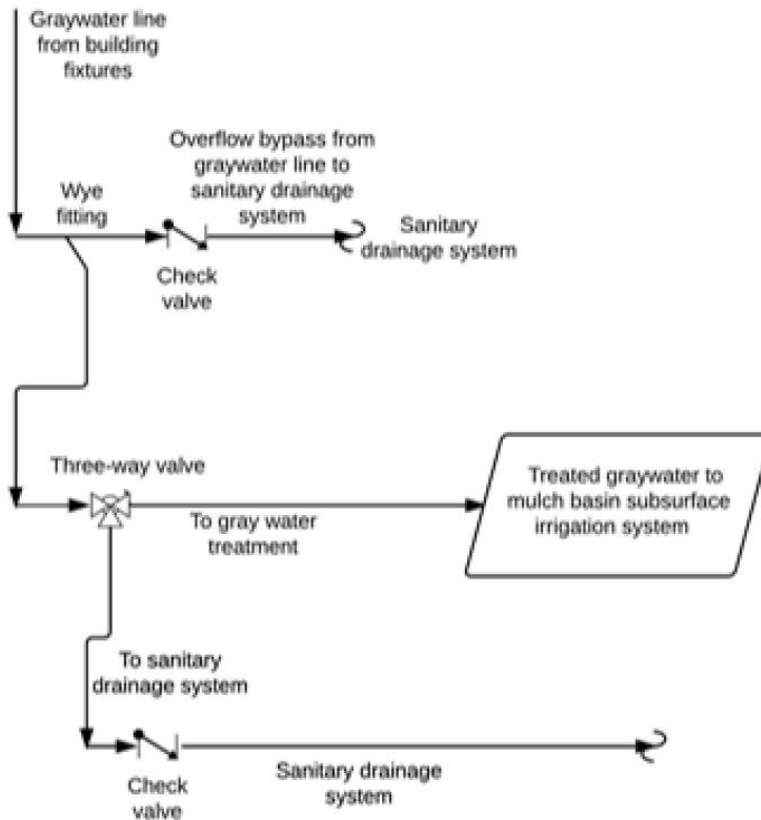

kkjjj. IRC Section 2910.9.3 Materials

Add section Exemption to read:

Exemption. Tanks are not required if the graywater use is comprised of only subsurface irrigation and flows into a mulch basin system, where the mulch basin volume is three times the anticipated average daily flow.

llkky. IRC Section 2911.5 Filtration

Delete the section in its entirety and replace with:

**P2911.5.1 Filtration.** Graywater used for dispersed subsurface irrigation system requires a cartridge filter. The cartridge filter must be a minimum of sixty mesh located between the storage tank and the irrigation system. If a pump is being used to pressurize the graywater distribution system the filter must be located after the pump. Filters shall be accessible for inspection and maintenance. Filters shall utilize a pressure gauge or other approved method to provide indication

Commented [YJ30]: CDPHE addition

Formatted: Indent: Left: 1", First line: 0", Tab stops: Not at 0.5" + 1" + 1.5"

---

when a filter requires servicing or replacement. Filters shall be installed with shutoff valves immediately upstream and downstream to allow for isolation during maintenance.

Exemption. Filtration is not required for mulch basin subsurface irrigation systems.

Commented [YJ31]: CDPHE addition

Formatted: Indent: First line: 0"

mml#z. IRC Section P2911.7.6 Overflow

Add a new Section P2911.7.6 that reads:

**P2911.7.6 Overflow.** Storage tank for on-site nonpotable systems must include an overflow line without a shut off valve. The overflow line shall be connected to the sanitary sewer ~~either directly or~~ indirectly. The overflow line must be the same or larger diameter line than the tank influent line. The overflow line connected indirectly must be trapped to prevent the escape of gas vapors from the tank.

nnmmaa. IRC Section P2911.7.4 Venting

Add a new Section P2911.7.4 that reads:

**P2911.7.4 Venting.** Storage tank for on-site nonpotable systems must be vented to the atmosphere or connected to the plumbing system vent piping.

oornbb. IRC Section P2911.7.5 Draining of tanks

Add a new Section P2911.7.5 that reads:

**P2911.7.5 Draining of tanks.** Storage tank for on-site nonpotable systems must include a valved drain. The drain line shall be connected to the sanitary sewer either directly or indirectly. The tank drain line must be the same or larger diameter line than the tank influent line.

ppeeee. IRC Section P2911.8.1 Bypass valve

Section P2911.8.1 System Bypass

Delete the section verbiage and replace with:

One three-way diverter valve listed and labeled to NSF 50 or other approved device shall be installed on collection piping upstream of any graywater treatment equipment, as applicable, to divert untreated on-site reuse sources to the sanitary sewer to allow servicing and inspection of the system. Bypass valves shall be installed downstream of fixture traps and vent connections. Bypass valves shall be marked to indicate the direction of flow, connection ~~and storage tank or drainfield connection to graywater treatment works, storage tank and graywater subsurface irrigation system.~~ Bypass valves shall be installed in accessible locations. Two shutoff valves shall not be installed to serve as a bypass valve. In addition to the bypass valve a series of drainage fittings shall be installed in the collection piping upstream of the bypass valve in a configuration that will allow the graywater from the plumbing fixtures to automatically flow directly into the sanitary sewer system in the event the filter or other parts of the collection system become clogged to the point of not allowing the effluent free

---

---

flow through the system. The overflow line connected to the sanitary sewer shall be equipped with a backwater valve.

~~ggpp.~~ IRC Section P3003.9.2 Solvent cementing

~~Delete exception in its entirety.~~

~~rrqqdd.~~ IRC Section P3009 Subsurface landscape irrigation systems

~~Delete in its entirety.~~

~~ssee.~~ IRC Table P3005.1 Fittings for changes in direction

Delete footnotes a and b from the table.

~~fftt.~~ IRC Section P3005.2.3 Building drain and building sewer junction.

~~Add new sentence at the end of the section to read:~~

~~When the cleanout is installed at the junction of the building drain and building sewer, it shall be an approved two way fitting with a single riser not to exceed 4 feet in depth or a two riser cleanout using back to back combination fittings of schedule 40 material.~~

~~ssuu.~~ IRC Section P3008.1 Where required (backwater valves)

~~Delete section in its entirety and replace with:~~

~~Backwater valves shall be installed where waste receptors are located in a crawl space for the purpose of receiving condensate discharge from equipment located in that crawl space. Refer to new exception for 802.4~~

~~vvtt.~~ IRC Section P3009 Subsurface landscape irrigation systems

~~Delete in its entirety.~~

~~wwwuff.~~ IRC Section P3103.2 Frost closure

Delete in its entirety.

~~wxxegg.~~ IRC Section P3108.1 Horizontal wet vent permitted

Add a new exception to read:

**Exception:** Fixtures other than those considered to be bathroom group fixtures, of equivalent drainage fixture units, may be included in the wet vented section provided the total number of drainage fixture units does not exceed the total number included in two bathroom groups and the fixtures not considered bathroom fixtures are valued at one drainage fixture unit or less.

3. Revisions and exceptions to the International Fuel Gas Code incorporated as the Colorado Fuel Gas Code

a. IFGC Section 101.1 Title

Delete in its entirety.

---

Formatted: Font color: Auto

Commented [YJ32]: PPRBD note

Formatted: Font color: Auto

Formatted: Font color: Auto

---

b. IFGC Section 101.2.2 Piping Systems

Delete the words "and maintenance" from the end of the last sentences.

~~c. IFGC Section 101.2.4 Systems, appliances and equipment outside the scope.~~

~~Delete 13 from the list.~~

ed. IFGC Section 303.3 Prohibited locations

Delete the words "toilet rooms" from the section.

ee. IFGC Section 310.1.1 CSST

Add a new exception to read:

**Exception:** Conductive Jacketed Corrugated Stainless Steel Tubing (CSST) with arc resistant jacketing complying with Listing LC1024 from the ICC Evaluation Service shall be installed per the manufacturer's installation instructions and the listing's requirements.

ef. IFGC Section 403.10.5 Welded joints

Add new section 403.10.5 to read:

**403.10.5 Welded Joints.** Welded joints shall be performed by a person holding a valid certificate of competency based on the requirements of the ANSI/ASME Boiler and Pressure Vessel Code, Section IX, Brazing and Welding Qualifications. Welded joints shall comply with ASTM 139.

fg. IFGC Section 406.1 Inspection, Testing, and Purging

Add a new sentence to the end of the section reading:

Inspection and pressure testing shall apply to all temporary installations connected to a primary or temporary fuel gas source, natural or LP gas, for the purpose of supplying temporary heat.

~~gh. IFGC Section 408.4 Sediment trap~~

~~Delete in its entirety~~

hi. IFGC Section 409.5.3 Located at manifold

Delete in its entirety.

ij. IFGC 409.6 Shutoff valve for laboratories

Add new subsection 409.6.1 to read

**409.6.1 Electric Solenoid Valve.** A remotely located electric solenoid emergency shutoff valve may be used for compliance to Section 409.6, when all the following requirements are met.

- (1) The emergency control shutoff "panic button" shall be readily accessible, located within the laboratory space served, adjacent to the egress door

Commented [MD33]: Correct lettering

---

from the space and shall be identified by approved signage stating "Gas Shutoff".

- (2) The gas solenoid valve shall be a "normally closed" type valve with a manual reset.

~~k.~~ IFGC Section 503.4.1 Plastic Piping.

Add new sentence to the end of the section saying:

Where installed as an exhaust vent for a gas fired water heater, the new plastic pipe shall be tested with 5 psi maximum air pressure at the time of inspection prior to being connected to the water heater.

4. Revisions and exceptions to the International Residential Code Chapter 24 Fuel Gas incorporated as the Colorado Fuel Gas Code

a. ~~IRC~~IFGC Section G2414.10.5 Welded joints

Add new section G2414.10.5 Welded joints to read:

**Welded joints.** Welded joints shall be performed by a person holding a valid certificate of competency based on the requirements of the ANSI/ASME Boiler and Pressure Vessel Code, Section IX, Brazing and Welding Qualifications. Welded joints shall comply with ASTM 139.

b. IRC Section G2411.1 Gas Pipe Bonding

Add a new exception to read:

**Exception:** Conductive Jacketed Corrugated Stainless Steel Tubing (CSST) with arc resistant jacketing complying with Listing LC1024 from the ICC Evaluation Service shall be installed per the manufacturer's installation instructions and the listing's requirements.

~~c.~~ IRC Section G2419.4 Sediment Trap

Delete in its entirety.

~~cd.~~ IRC Section G2420.5.3 (Shutoffs) Located at manifolds

Delete in its entirety.

~~de.~~ IRC G2427.4.1 Plastic Piping.

Add new sentence to the end of the section saying:

Where installed as an exhaust vent for a gas fired water heater, the new plastic pipe shall be tested with 5 psi maximum air pressure at the time of inspection prior to being connected to the water heater.

### 1.3 APPRENTICE REGISTRATION AND RECORDKEEPING

#### A. Registration

---



- 
1. The Board may require the employersupervising plumbing contractor of a plumbing apprentice to provide information verifying the apprentice's record of employment and practical experience, including but not limited to a written attestation from the responsible master plumber verifying that the apprentice has been performing plumbing work during any period the apprentice was not registered. EmployersSupervising plumbing contractor of apprentices shall cooperate with any request from the Board pursuant to this Rule and furnish such information or assistance as the Board may request.
  2. An individual that holds an active residential plumber's license and is working on a commercial job site must be registered as an apprentice.
  3. An employer who fails to timely register an apprentice as required by section 12-155-108(2)(a), C.R.S., and this Rule shall be subject to disciplinary action pursuant to sections 12-155-113(1) and 12-20-404, C.R.S.

B. **Recordkeeping.** Supervising pPlumbing cContractors shall maintain employment records or work reports for their apprentices in order to provide experience verification. Such records or reports shall accurately document the number of hours and months the apprentice performed plumbing work and shall specifically reflect exact dates of employment. These records shall be provided to the apprentice upon his/her request or termination or resignation of an apprentice.

#### 1.4 APPLICATIONS AND LICENSING

A. Applications for License Examinations or Registrations.

Note: Applications received after December 1, 2019DATE must pass the required examination before submitting application to the Board with the required experience and education.

1. **Submission.** All applications for license examinations or registrations shall be submitted to the Division of Professions and Occupations.
2. **Incomplete Application.** An application for a license by examination or endorsement or a registration submitted without all required fees and documentation will be considered incomplete. Incomplete applications will be retained for one year from the date originally received, after which applicants shall begin the process again including payment of the application fee.
3. **Documentation for Plumbing License Examination.** Any applicant for the residential, journeyman, or master plumber's license exam shall furnish evidence as to his or her training and experience to qualify for the examination by:
  - a. A record of employment and/or as an apprentice doing plumbing work, exact dates so employed, and, at time of application, submission of original documented written evidence, verified by the master license holder or registered plumbing contractor
  - b. If training and experience were obtained outside the State of Colorado, the applicant shall provide the Board with documented, written evidence verified by the employer of actual work performed.
  - c. If training and experiences were obtained all or in part from an accredited high school vocational technical training course, community college, or trade school program, a transcript from the accredited high school vocational technical training course, community college or trade school verifying completion of the program shall be submitted with the application. The program length shall be a minimum of two years. Such education may replace actual field experience under a

Formatted: Font: Italic

Formatted: Font: Italic

licensed master as follows: one hour of classroom training equals one hour of on the job training up to a maximum of one year, with 2000 hours equaling one year.

d. If training and experiences were obtained all or in part from military training in plumbing work, detail and submit such for evaluation with the application. Such experience may replace actual field experience under a licensed master as follows: one month for every six months' training or experience up to a maximum of one year.

e. The hours of practical experience required to qualify for examinations are:

- (1) Residential Plumber 3,400
- (2) Journeyman Plumber 6,800
- (3) Master Plumber 8,500

~~information or documentation. This request shall be submitted within forty-five days of the date on which the Board made the decision. The Board may not consider requests filed thereafter.~~

Formatted: Indent: First line: 0"

D. ~~Repeal~~Temporary Work Permits

Formatted: Space After: 12 pt

1. ~~Issuance.~~ Pursuant to section 12-155-117, C.R.S., a temporary work permit may be issued at the time of approval for an examination. The temporary permit will be valid for a period of no more than thirty days after the date of approval or as otherwise limited in section 12-155-117, C.R.S.

2. ~~Not allowed.~~ A temporary work permit shall not be accepted to meet the requirements for a new contractor registration.

(a) ~~A temporary master plumber work permit may be issued to a qualified applicant of an existing plumbing contractor pursuant to section 12-155-117(4), C.R.S.~~

E. Renewal and Reinstatement (Effective July 1, 2020)

Formatted: Font: 10 pt

1. Renewal.

Formatted: Font: 10 pt, Italic

a. A licensee or registrant shall have a sixty-day grace period after the expiration of ~~his or her~~the license or registration to renew such license or registration without having to submit a reinstatement application. During this grace period a delinquency fee will be charged for late renewals.

Formatted: Font: 10 pt

Formatted: Font: 10 pt

Formatted: Indent: Left: 1"

2b. A licensee or registrant who does not renew his or her license or registration shall be ineligible to practice until such license or registration is reinstated. If the licensee or registrant practices with an expired license or registration, the Board may impose disciplinary actions.

23. Reinstatement. An expired license or registration may be reinstated by submitting a reinstatement application, ~~and~~ paying the current reinstatement fee, and meet the appropriate requirements below.

Formatted: Font: Bold

a. Expired for More Than Sixty Days But Less Than Two

Formatted: Indent: Left: 1"

b4. If Years. If the license or registration has expired for more than sixty days but less than two years or more, the applicant must provide evidence of completion, since applicant's most recent licensing event (original license, renewal, or reinstatement) preceding the application for reinstatement, of eight hours of continuing education, as defined in Board Rule 1.4(E)(3).

Formatted: Font: 10 pt

Formatted: Font: 10 pt

cb. Expired for More Than Two Years. If the licensee or registrant has been expired for more than two years, pursuant to section 12-155-112(2)(b)(II), C.R.S. the applicant must ~~shall~~ demonstrate competency to practice by satisfactorily passing the State plumbing examination. In the case of Water Conditioning Installers and Water Conditioning Principals, registrants shall re-affirm that their certifications per board Rule 1.4(A)(5) are current and active.

Formatted: Font: 10 pt

Formatted: Font: 10 pt

### 3. Continuing Education Requirements

Formatted: Font: Bold

a. Statutory Basis. Pursuant to section 12-155-112(3)(b) C.R.S, the Board shall adopt rules establishing continuing education requirements and standards that a licensee shall demonstrate in order to renew a license on or after May 1, 2021. Such requirements and standards must include course work related to the code, including core competencies as determined by the board.

b. Basis of Requirements. As established by the Colorado General Assembly, the regulatory authority of the Board is to establish continuing education standards to renew, reinstate, or reactivate a license and the documentation necessary to demonstrate compliance.

#### c. Definitions

(1) Core Competencies: Core Competencies are technical and professional subjects, related to the practice of plumbing work, which the Board deems necessary to safeguard the public.

(2) Inactive Status: A licensee is not required to comply with continuing education requirements to renew a license in inactive status. An individual whose license is in inactive status is prohibited by law from practicing as a licensed plumber.

(3) Code: Code for the safe installation of plumbing installation, plumbing materials, conservation, medical gas, sanitary drainage systems, and solar plumbing.

(45) Attesting Providers List: A publically available list containing continuing education providers that have attested their courses and instructors meet all the requirements of Board Rule 1.4(E)(3)(d) and 1.4(E)(3)(e). Credit may be earned by a licensee by completing a course from a provider on this list. However, licensee are responsible for ensure the providers they choose, meet the requirements of the CE requirements in Board Rule 1.4(E)(3).

#### d. Requirements

(1) Each renewal cycle after May 2021, or upon the completion of the first renewal of a license thereafter, a licensee in active status shall complete eight hours of continuing education for every twelve months that have passed after the later of the last date of renewal or reinstatement in order to renew a license to perform plumbing work in Colorado. The continuing education hours must be selected from among the Core Competencies

---

below in any combination, except that, within every twenty-four month period, a minimum of 4 continuing education hours must be related to codes as defined in Board Rule 1.2 and a maximum of 2 hours can be related to safety training:

(a) Cross connection and backflow prevention

(b) Fixtures, Faucets and Fixture Fittings

(c) Indirect/Special Waste

(d) Industry Product Training

(e) Non-potable Water Systems

(f) Plumbing Administration

(g) Residential Fire Sprinkler Systems

(h) Sanitary Drainage

(i) Special Piping (Medical Gas)

(j) Storm Drainage

(k) System piping and components

(l) Traps, Interceptors and Separators

(m) Vents - DVM

(n) Water Heaters

(o) Water Supply and Distribution

(p) Safety related to the plumbing industry.

(2) Colorado Plumbing Code. In addition to the requirements of 1.4(E)(3)(d)(1), licensees must make attestation upon renewal that they have read the current Colorado Plumbing Code in Board Rule 1.2.

(3) Continuing education credits will only apply to each twelve month period after the later of the last date of renewal or reinstatement

(4) Licensees shall cooperate with the Board to determine compliance with continuing education requirements.

(5) The requirements stated in Board Rule 1.4(E)(3) shall apply to:

(a) All original plumbing licenses granted after July 1, 2021;

(b) All plumbing licenses upon completion of the 2021 renewal; and,

(c) All plumbers are subject to Board Rule

---

---

Pursuant to section 12-155-112(2)(c), C.R.S. continuing education requirements within section 12-155-112(3)(a), C.R.S. do not apply to water conditioning installers or water conditioning principles.

e. Attesting Providers. Continuing education providers must be listed with the Board and attest that their courses and instructors meet the continuing education requirements of Board Rule sections 1.4 (E)(3)(d)(1) through (4). The list of Attesting Providers with expire on December 31st of the final year of the current code cycle.

(1) The Board has sole discretion to accept providers that have attested.

(2) Providers. Providers may attest that they meet the CE requirements if their courses and instructors meet all the requirements of Board Rule 1.4(E)(3)(e)(4).

(a) As proof of course completion, the Board will accept a certificate of completion from the course provider.

(b) Certificates of completion shall not be issued to attendees unless the course is successfully completed. Certificates of completion shall include all of the following elements:

(i) Name of attendee;

(ii) Attendee's Colorado plumber's license number;

(iii) Date of course;

(iv) Provider name and approval number;

(v) Course title;

(vi) Instructor name; and

(vii) Number hours of continuing education credit earned.

(3) Courses. Criteria for courses from Attesting Providers shall include the following:

(a) Each course shall cover a minimum of one core competency, as listed in Board Rule 1.4(E)(3)(d)(1). Course credit will apply to only one core competency per course.

(b) All online courses or webinars shall be interactive. Each course must have capabilities in place to ensure active participation and demonstrate comprehension a minimum of once per hour, and fast-forward must be disabled.

(4) Instructors. Courses must be taught by instructors with the following qualifications:

(a) Instructors must be sponsored by the Attesting Provider.

(b) Instructor's background and experience must meet at least one of the following criteria.

---

- (i) Hold a minimum of a Colorado master plumber's license or journeyman plumber's license (or equivalent) plus a minimum of five years of journeyman plumber field experience;
- (ii) Community college or vo-tech instructor as approved by the Board;
- (iii) Plumbing continuing education instructor from other areas as approved by the Board; or,
- (iv) Instructor shall provide documentation of background and experience as requested by the Board.

- (5) Once attesting they meet the qualifications as an Attesting Provider, providers will be placed on an Attesting Provider list.
- (6) The Board has sole discretion to accept or reject any continuing education credit earned by a licensee from a provider that is, or is not, on the list.
- (7) The Board has discretion to remove providers from the list.
- (8) It is the responsibility of the licensee to ensure the continuing education obtained meets the requirements of this section 1.4(3)(E).

f. Recordkeeping

- (1) The licensee shall track and document completed continuing education in a process approved by the Board.
- (2) The licensee shall retain documentation for a minimum of six years.

g. Audits

- (1) The Board may conduct audits of continuing education for verification of compliance with these requirements at any time. The Board may, at its discretion, disallow any continuing education course completed by a licensee that was offered by a provider on the Attesting Provider list.
- (2) A licensee shall provide all documentation requested for audit within thirty days of the request.

h. Multiple Licenses. A licensee holding multiple licenses issued by the Board shall complete continuing education requirements for the most advanced license held. Completion of continuing education requirements for the most advanced license shall satisfy the requirements for all lesser licenses.

**4. Inactive License Status and Reactivation**

- a. Inactive License. Pursuant to section 12-70-101, C.R.S., any licensee may apply to the Board to transfer his or her license to inactive status. Such application shall be in the form and manner designated by the Board. The holder of an inactive license shall not be required to comply with continuing education requirements for renewal so long the license remains inactive.

Formatted: Font: Bold

(1) Each holder of an inactive license shall renew once every two years with the Board in the same manner as active license holders and pay a fee pursuant to section 12-155-105(1)(d), C.R.S.

(2) During such time as a license remains in an inactive status, the licensee shall not perform any acts restricted to active licensed plumbers. Such practice may be grounds for revocation.

b. Reactivation of Inactive License. An inactive license may be reactivated by submitting the proper application, paying the current reactivation fee, and meeting the appropriate requirements below.

(1) Inactive for Less Than Three Years. To reactivate a license that has been inactive for less than three years, the applicant must provide evidence of completion, within the three years immediately preceding the application for reinstatement, of twenty-four hours of continuing education, as defined in Board Rule 1.4(e)(3)

(2) Inactive for More Than Three Years. Pursuant to section 12-115-110(4)(c), C.R.S., a licensee whose license has been inactive for more than three years must demonstrate education to practice by any of the following:

(a) Satisfactorily pass the state plumbing examination.

(b) Provide verification of an active license with a state where a reciprocal agreement for an equivalent license exists.

(c) Provide verification of active licensure in a non-reciprocal state as follows:

(i) Verify an active residential plumber's license, journeyman plumber's license, or master plumber's license in non-reciprocal state, respective to the license you are reinstating;

(ii) Evidence of completing twenty-four continuing education hours pursuant to Board Rule 1.11(C) in the three years immediately preceding the application for reinstatement; and,

(iii) By other means approved by the Board.

(3) Practicing with an Inactive License. Practicing plumbing work with a license in inactive status shall constitute practice without an active license and, therefore, may be grounds for injunctive or disciplinary action, up to and including revocation.

Formatted: Space After: 12 pt

Formatted: Font: 10 pt

Formatted: Indent: Left: 1.5"

5. Registered Plumbing and Water Conditioning Contractors with expired permits shall not have their contractor registrations renewed until such time as all expired permits are cleared or as otherwise allowed by the Board.

## 1.6 PERMITS AND INSPECTIONS

---

B. Inspections

8. **Provide services.** A utility purveyor shall not provide service to any structure required to have gas inspections required by section 12-155-120(1), C.R.S., without proof of ~~final~~ approval. ~~Final a~~Approval shall be indicated by the presence of a "Blue Tag" affixed to the gas piping system at the point of utility connection. ~~Final a~~Approval may also be granted verbally or in writing by the inspector or his/her supervisor.

